

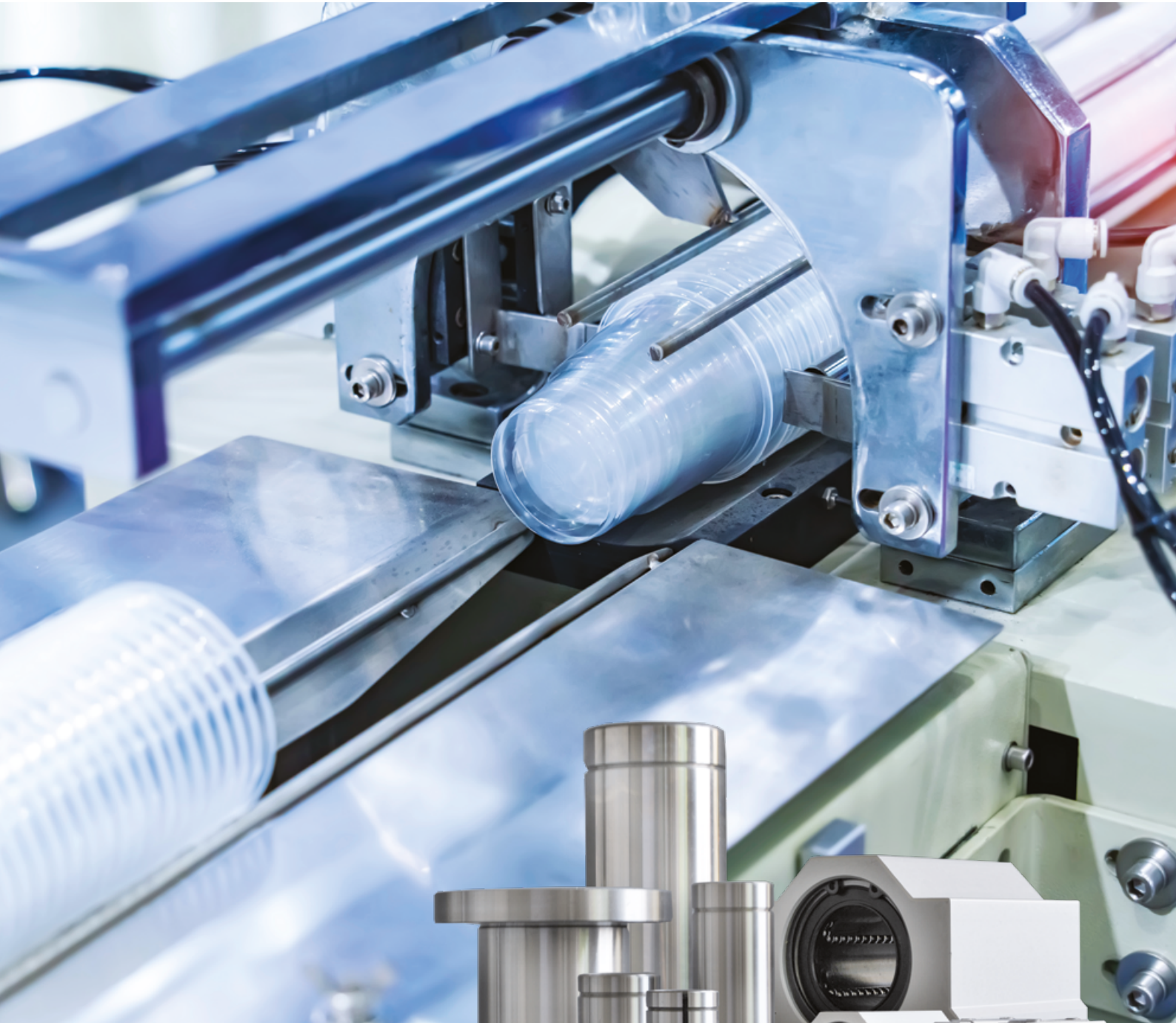

Brand of NTN Group

LINEAR MOTION: BALL BUSHINGS



NTN EUROPE, THE STRENGTH OF A GROUP



Production facility in Bielefeld

As one of the leading manufacturers of rolling bearings in Europe, NTN Europe has been, for many years, among the most innovative companies within its sector of industry.

Since April of 2008, SNR has been a part of a corporate group together with the Japanese company NTN, making it the third largest manufacturer of rolling bearings in the world. Hence, we are able to offer added value to our customers with reference to product variety, quality and service. Our company is clearly identified through a worldwide presence and through its continuous quality system.

Since 1985, we are also active in the market of linear technics. Our extensive line of products within linear technics, our know-how and our made-to-measure services have made us renowned with our customers as a highly efficient partner. It does not matter if for instance it concerns machine components such as ball screws, the attached fixed – and floating bearing units, ball bushings and shafts,

or whether you require a linear module as a single-axis or a multi-axes system. NTN Europe offers you specific and individual customer solution concepts.

Our delivery program for ball bushings, shafts and shaft supports offers an extensive variety of DIN ball bearings, as well as models that are completely different. The program is completed by full bearing units including the casing or shaft toolings according to individual customer orders. By way of our wide product program, you will surely be able to find a suitable solution for your application(s). We also provide support with reference to the development of system solutions. Our extensive network of sales and technical engineers will offer you individual advice on-site and they will provide you with specific solutions for your individual application(s).

This technical catalog is the foundation for a meaningful dialogue with you.

We look forward to receiving your order –
We are most happy to welcome you as our customer!

**WE LEAD YOU TOWARDS RELIABILITY
AND PERFORMANCE.**

Ball bushings	4	Support rail	60
ISO dimensions	4	Without flange (Series SR 10)	60
Standard ball bushings, closed	4	With flange (Series SR 20)	61
Standard ball bushings, open	6	For lateral fastening with one row of holes	62
Standard ball bushings, adjustable	8	For lateral fastening with a double row of holes	63
Standard flanged ball bushings (round)	10	Shaft supports	64
Tandem standard ball bushings	12	Traverse	65
Tandem flanged standard ball bushings (round)	14	Shafts	66
Middle flanged standard ball bushings (round)	16	Matrix in function of the pre-selection of solid shafts and hollow shafts	66
JIS dimensions	18	Steel, surface hardness, depth of hardness	66
Ball bushings, closed	18	Dimension accuracy and tolerance field	66
Super ball bushings (closed, open)	20	Solid shafts	67
Ball sleeves KH Series	22	Hollow shafts	67
Linear units with standard ball bushings, relubrication	24	Shaft tooling	68
Linear units with standard ball bushings	24	Examples of tooling	70
Closed casing	24	Type designation code	72
Closed casing and adjustable clearance	26	General information	74
Open casing	28	Introduction	74
Open casing and adjustable clearance	30	Load ratings	74
Casing at one side	32	Relation between the rows of balls and the load rating	75
Casing open on one side and adjustable clearance	34	Material	76
Tandem linear units with standard ball bushings	36	Service life	77
Closed casing	36	Lubrication and friction	80
Closed casing and adjustable clearance	38	Fittings	82
Open casing	40		
Open casing and adjustable clearance	42		
Quadro linear units with standard ball bushings	44		
Closed casing	44		
Open casing	46		
Linear units with super ball bushings, relubrication	48		
Linear units with super ball bushings	48		
Closed casing	48		
Open casing	50		
Open casing and adjustable clearance	52		
Tandem linear units with super ball bushings	54		
Closed casing	54		
Open casing	56		
Open casing and adjustable clearance	58		

Ball bushings

ISO dimensions

Standard ball bushings, closed



The closed ball bushings of the BBE series according to ISO 10285 are widely utilized in various applications because of their precise cylindrical shape and good operational qualities.

The standard ball bushings can be supplied from stock, with two wiper seals. The required seals are to be included when ordering.

Optional relubricable

- Examples of order reference for a ball bushings with single-sided seal: BBE12U, BBE12AU
- Examples of order reference for a ball bushings with double-sided seal: BBE12UU, BBE12AUU
- Examples of order reference for a ball bushings with double-sided seal, relubricable: BBE12UU-RL

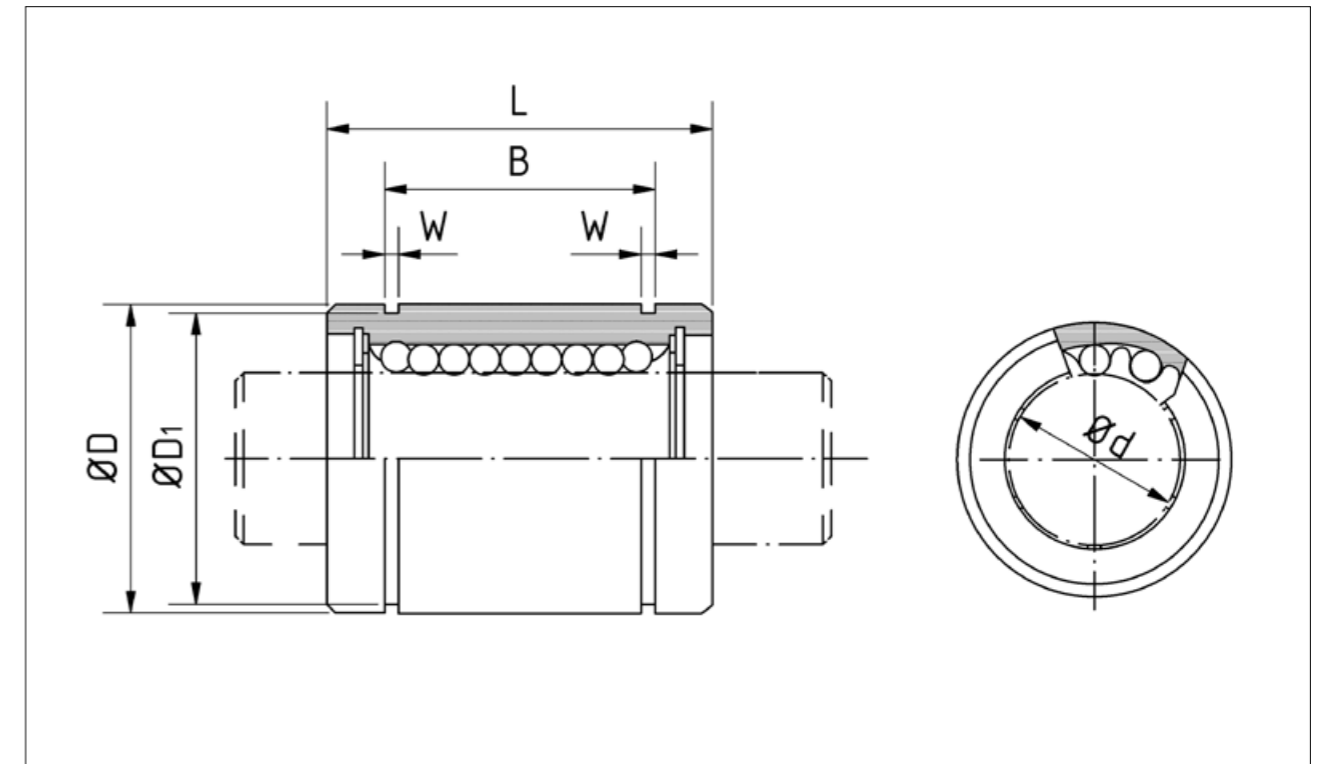

Order reference				Dimensions [mm]							
Standard		Corrosion-resistant		Ød	Tolerance	ØD	Tolerance	L	Tolerance	B	Tolerance
Plastic cage	Steel cage	Plastic cage	Stainless steel cage								
BBE3	BBE3A	BBES3	BBES3A	3	+0,008 0	7	0 -0,008	10	0 -0,012	-	-
BBE4	BBE4A	BBES4	BBES4A	4		8		-		-	
BBE5	BBE5A	BBES5	BBES5A	5		12		14,5		0 -0,2	
BBE8	BBE8A	BBES8	BBES8A	8		16		16,5			
BBE10	BBE10A	BBES10	BBES10A	10	19	22					
BBE12	BBE12A	BBES12	BBES12A	12	22	22,9	0 -0,009	0 -0,2			
BBE16	BBE16A	BBES16	BBES16A	16	26	24,9					
BBE20	BBE20A	BBES20	BBES20A	20	32	31,5					
BBE25	BBE25A	BBES25	BBES25A	25	40	44,1					
BBE30	BBE30A	BBES30	BBES30A	30	47	52,1	0 -0,011	0 -0,3			
BBE40	BBE40A	BBES40	BBES40A	40	62	60,6					
BBE50	BBE50A	BBES50	BBES50A	50	75	77,6					
BBE60	BBE60A	BBES60	BBES60A	60	90	101,7					
-	BBE80A	-	-	80	+0,016 -0,004	120	0 -0,015	165	0 -0,4	133,7	0 -0,4

W	Ø D1	Rows of balls	Max. eccentricity [µm]	Max. radial clearance [µm]	Dynamic load rating [N]	Static load rating [N]	Weight [g]	Order reference			
								Standard	Corrosion-resistant	Plastic cage	Steel cage
-	-	4	10	-3	44	105	1,4	BBE3	BBE3-A	BBES3	BBES3-A
-	-	4			55	127	2	BBE4	BBE4-A	BBES4	BBES4-A
1,1	11,5	4			159	265	11	BBE5	BBE5-A	BBES5	BBES5-A
1,1	15,2	4			195	402	22	BBE8	BBE8-A	BBES8	BBES8-A
1,3	18	4	12	-4	286	549	36	BBE10	BBE10-A	BBES10	BBES10-A
1,3	21	4			419	784	45	BBE12	BBE12-A	BBES12	BBES12-A
1,3	24,9	4			432	892	60	BBE16	BBE16-A	BBES16	BBES16-A
1,6	30,3	5			877	1 370	102	BBE20	BBE20-A	BBES20	BBES20-A
1,85	37,5	6	15	-6	908	1 570	235	BBE25	BBE25-A	BBES25	BBES25-A
1,85	44,5	6			1 584	2 740	360	BBE30	BBE30-A	BBES30	BBES30-A
2,15	59	6			2 357	4 020	770	BBE40	BBE40-A	BBES40	BBES40-A
2,65	72	6			4 702	7 940	1 250	BBE50	BBE50-A	BBES50	BBES50-A
3,15	86,5	6	17	-13	6 085	9 800	2 220	BBE60	BBE60-A	BBES60	BBES60-A
4,15	116	6			9 456	16 000	5 140	BBE80	-	-	-

The indicated load ratings are applicable in case the load only applies to one row of balls. If, however, the force is shared between two rows of balls, the load capacity is increased (refer to table on page 75).

Standard ball bushings, open

Where bending (deflection) of the shaft has to be avoided, open standard ball bushings are utilized in combination with shaft supports. This is often the case for applications with extended travel. By way of the combination described above, the stiffness is in fact additionally increased.



The standard ball bushings can be supplied from stock, with two wiper seals. The required seals are to be included when ordering.

Optional relubricable

- Examples of order reference for a ball bushings with single-sided seal: BBE12U-OP, BBE12AU-OP
- Examples of order reference for a ball bushings with double-sided seal: BBE12UU-OP, BBE12AUU-OP
- Examples of order reference for a ball bushings with double-sided seal, relubricable: BBE12UU-OP-RL

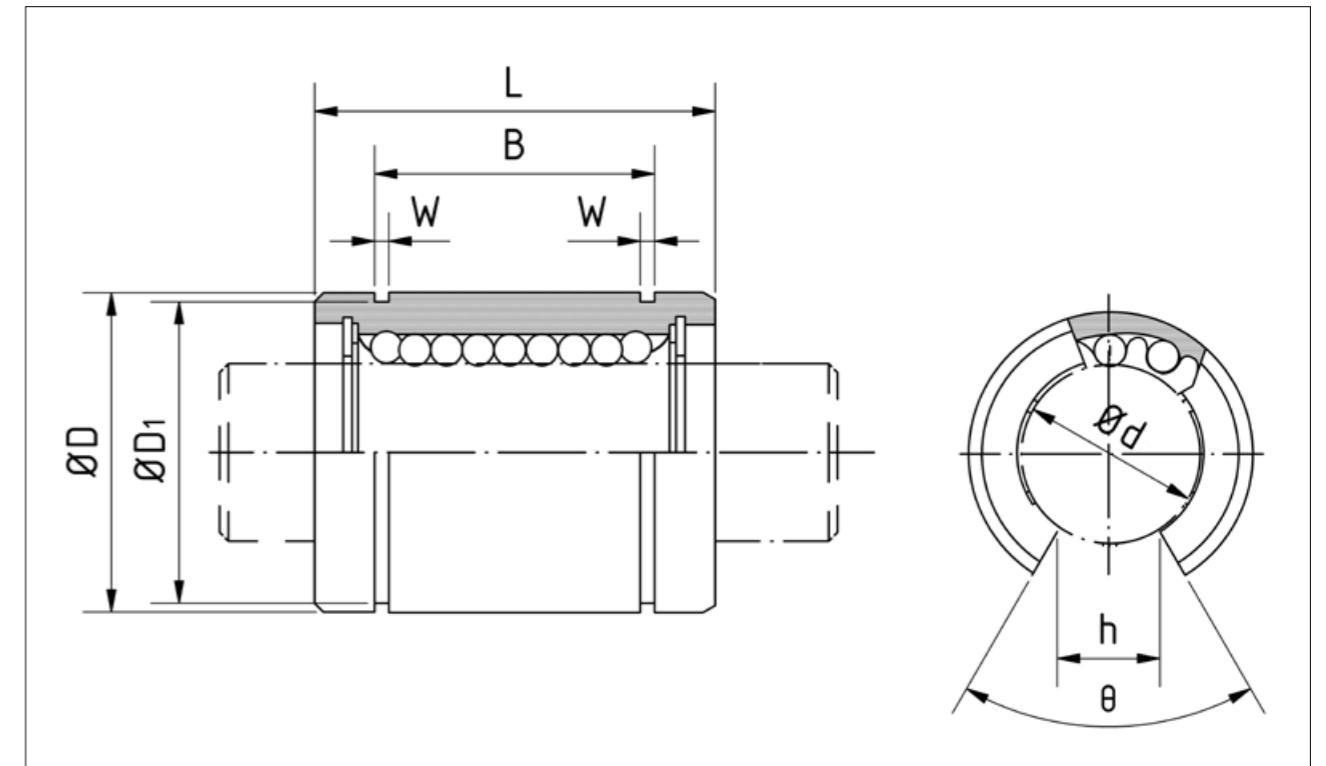

Order reference				Dimensions [mm]							
Standard		Corrosion-resistant		Ød	Tolerance	ØD	Tolerance	L	Tolerance	B	Tolerance
Plastic cage	Steel cage	Plastic cage	Stainless steel cage								
BBE10-OP	-	BBES10-OP	-	10	+0,008 0	19	0 -0,009	29	0 -0,2	22	0 -0,2
BBE12-OP	BBE12A-OP	BBES12-OP	BBES12A-OP	12		22		32		22,9	
BBE16-OP	BBE16A-OP	BBES16-OP	BBES16A-OP	16	+0,009 -0,001	26		36		24,9	
BBE20-OP	BBE20A-OP	BBES20-OP	BBES20A-OP	20		32		45		31,5	
BBE25-OP	BBE25A-OP	BBES25-OP	BBES25A-OP	25	+0,011 -0,001	40	0 -0,011	58		44,1	
BBE30-OP	BBE30A-OP	BBES30-OP	BBES30A-OP	30		47		68	0 -0,3	52,1	0 -0,3
BBE40-OP	BBE40A-OP	BBES40-OP	BBES40A-OP	40		62	0 -0,013	80		60,6	
BBE50-OP	BBE50A-OP	BBES50-OP	BBES50A-OP	50	+0,013 -0,002	75		100		77,6	
BBE60-OP	BBE60A-OP	BBES60-OP	BBES60A-OP	60		90	0 -0,015	125	0 -0,4	101,7	0 -0,4
-	BBE80A-OP	-	-	80	+0,016 -0,004	120		165		133,7	

Dimensions [mm]			θ [°]	Rows of balls	Max. eccentricity [µm]	Dynamic load rating [N]	Static load prating [N]	Weight [g]	Order reference			
W	ØD1	h							Standard		Corrosion-resistant	
									Plastic cage	Steel cage	Plastic cage	Stainless steel cage
1,3	18	6,8	80	3		286	549	23	BBE10-OP	-	BBES10-OP	-
1,3	21	7,5	78	3	12	416	784	35	BBE12-OP	BBE12A-OP	BBES12-OP	BBES12A-OP
1,3	24,9	10	78	3		432	892	48	BBE16-OP	BBE16A-OP	BBES16-OP	BBES16A-OP
1,6	30,3	10	60	4	15	877	1 370	84	BBE20-OP	BBE20A-OP	BBES20-OP	BBES20A-OP
1,85	37,5	12,5	60	5		908	1 570	195	BBE25-OP	BBE25A-OP	BBES25-OP	BBES25A-OP
1,85	44,5	12,5	50	5		1 584	2 740	309	BBE30-OP	BBE30A-OP	BBES30-OP	BBES30A-OP
2,15	59	16,8	50	5	17	2 357	4 020	665	BBE40-OP	BBE40A-OP	BBES40-OP	BBES40A-OP
2,65	72	21	50	5		4 702	7 940	1 080	BBE50-OP	BBE50A-OP	BBES50-OP	BBES50A-OP
3,15	86,5	27,2	54	5	20	6 085	9 800	1 900	BBE60-OP	BBE60A-OP	BBES60-OP	BBES60A-OP
4,15	116	36,3	54	5		9 465	16 000	4 380	-	BBE80A-OP	-	-

The indicated load ratings for open ball bushings are only applicable where the load is applied from above; if the load is applied from the 'open direction', the load capacity is reduced by the following factor (refer to table on page 75).

Standard ball bushings, adjustable



The slotted standard ball bushings can be built into a casing with an adjustable internal diameter, allowing the clearance between the shaft and the ball bearing to be set.

The standard ball bushings can be supplied from stock, with two wiper seals. The required seals are to be included when ordering.

Optional relubricable

- Examples of order reference for a ball bushings with single-sided seal: BBE12U-AJ, BBE12AU-AJ
- Examples of order reference for a ball bushings with double-sided seal: BBE12UU-AJ, BBE12AUU-AJ
- Examples of order reference for a ball bushings with double-sided seal, relubricable: BBE12UU-AJ-RL

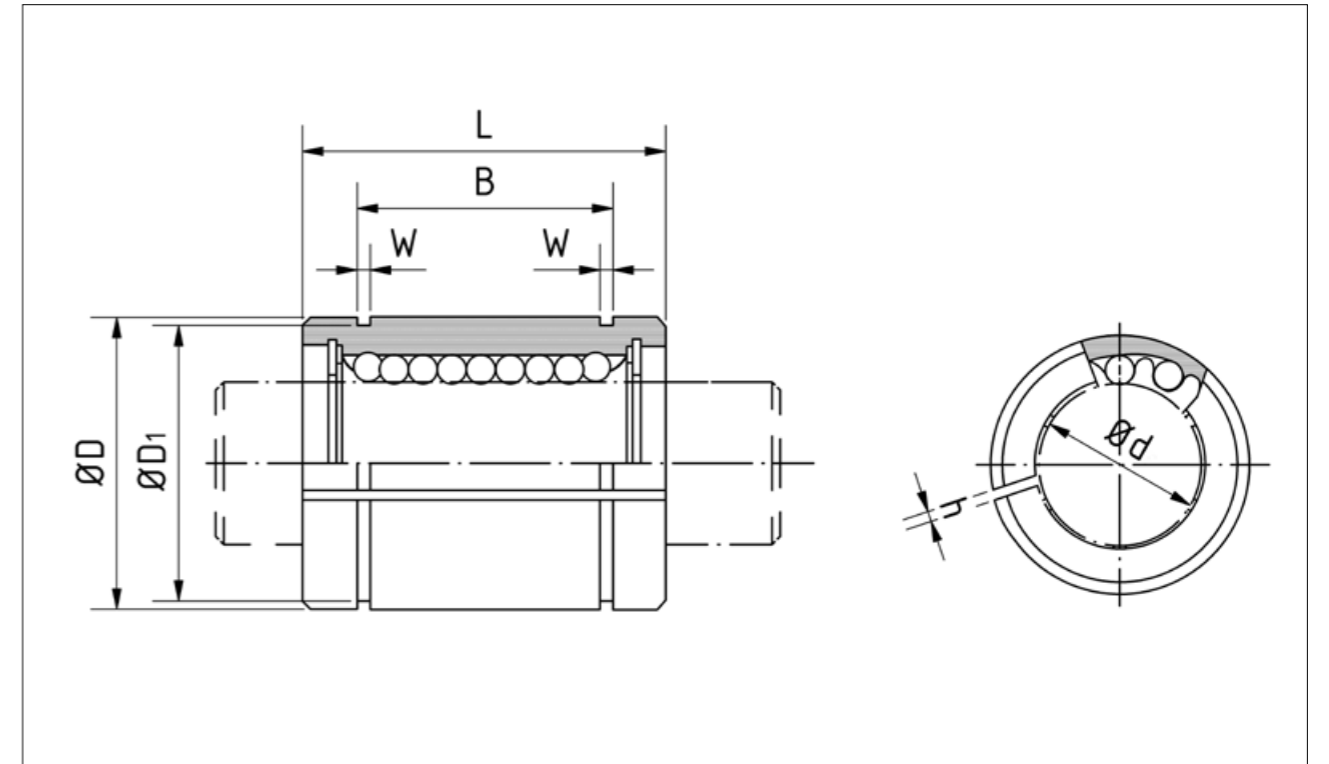

Order reference				Dimensions [mm]							
Standard		Corrosion-resistant		Ød	Tolerance	ØD	Tolerance	L	Tolerance	B	Tolerance
Plastic cage	Steel cage	Plastic cage	Stainless steel cage								
BBE5-AJ	-	BBES5-AJ	-	5	+0,008 0	12	0	22	0 -0,2	14,5	0 -0,2
BBE8-AJ	-	BBES8-AJ	-	8		16	-0,008	25		16,5	
BBE10-AJ	-	BBES10-AJ	-	10		19	0	29		22	
BBE12-AJ	BBE12A-AJ	BBES12-AJ	BBES12A-AJ	12	+0,009 -0,001	22	0	32	0 -0,2	22,9	0 -0,2
BBE16-AJ	BBE16A-AJ	BBES16-AJ	BBES16A-AJ	16		26	-0,009	36		24,9	
BBE20-AJ	BBE20A-AJ	BBES20-AJ	BBES20A-AJ	20		32	0	45		31,5	
BBE25-AJ	BBE25A-AJ	BBES25-AJ	BBES25A-AJ	25	+0,011 -0,001	40	0	58	0 -0,3	44,1	0 -0,3
BBE30-AJ	BBE30A-AJ	BBES30-AJ	BBES30A-AJ	30		47	-0,011	68		52,1	
BBE40-AJ	BBE40A-AJ	BBES40-AJ	BBES40A-AJ	40		62	0	80		60,6	
BBE50-AJ	BBE50A-AJ	BBES50-AJ	BBES50A-AJ	50	+0,013 -0,002	75	0	100	0 -0,4	77,6	0 -0,4
BBE60-AJ	BBE60A-AJ	BBES60-AJ	BBES60A-AJ	60		90	0	125		101,7	
-	BBE80A-AJ	-	-	80		120	-0,015	165		133,7	

Dimensions [mm]				Max. eccentricity [µm]	Dynamic load rating [N]	Static load rating [N]	Weight [g]	Order reference			
W	ØD1	h	Rows of balls					Standard		Corrosion-resistant	
								Plastic cage	Steel cage	Plastic cage	Stainless steel cage
1,1	11,5	1	4	12	159	265	10	BBE5-AJ	-	BBES5-AJ	-
1,1	15,2	1	4		195	402	19,5	BBE8-AJ	-	BBES8-AJ	-
1,3	18	1	4		286	549	29	BBE10-AJ	-	BBES10-AJ	-
1,3	21	1,5	4		416	784	44	BBE12-AJ	BBE12A-AJ	BBES12-AJ	BBES12A-AJ
1,3	24,9	1,5	4		432	892	59	BBE16-AJ	BBE16A-AJ	BBES16-AJ	BBES16A-AJ
1,6	30,3	2	5	15	877	1 370	100	BBE20-AJ	BBE20A-AJ	BBES20-AJ	BBES20A-AJ
1,85	37,5	2	6		908	1 570	230	BBE25-AJ	BBE25A-AJ	BBES25-AJ	BBES25A-AJ
1,85	44,5	2	6		1 584	2 740	355	BBE30-AJ	BBE30A-AJ	BBES30-AJ	BBES30A-AJ
2,15	59	3	6	17	2 357	4 020	758	BBE40-AJ	BBE40A-AJ	BBES40-AJ	BBES40A-AJ
2,65	72	3	6		4 702	7 940	1 230	BBE50-AJ	BBE50A-AJ	BBES50-AJ	BBES50A-AJ
3,15	86,5	3	6		6 085	9 800	2 170	BBE60-AJ	BBE60A-AJ	BBES60-AJ	BBES60A-AJ
4,15	116	3	6	20	9 465	16 000	5 000	-	BBE80A-AJ	-	-

The indicated load ratings are applicable in case the load only applies to one row of balls. If, however, the force is shared between two rows of balls, the load capacity is increased by the following factor (refer to table on page 75).

Standard flanged ball bushings (round)



Flanged ball bushings of the BBER series represent a useful addition to the standard ball bushings.

They offer the following advantages:

- The integrated flange design enables a more efficient arrangement of the housing or mounting holes.
- The flanged ball bushings are economical, because fewer components are required and altogether the installation is easier.
- The replacement of the ball bushings is easier.

The standard ball bushings can be supplied from stock, with two wiper seals. The required seals are to be included when ordering.

Optional relubricable

- Examples of order reference for a ball bushings with single-sided seal: BBER12U, BBER12AU
- Examples of order reference for a ball bushings with double-sided seal: BBER12UU, BBER12AAU
- Examples of order reference for a ball bushings with double-sided seal, relubricable: BBER12UU-RL

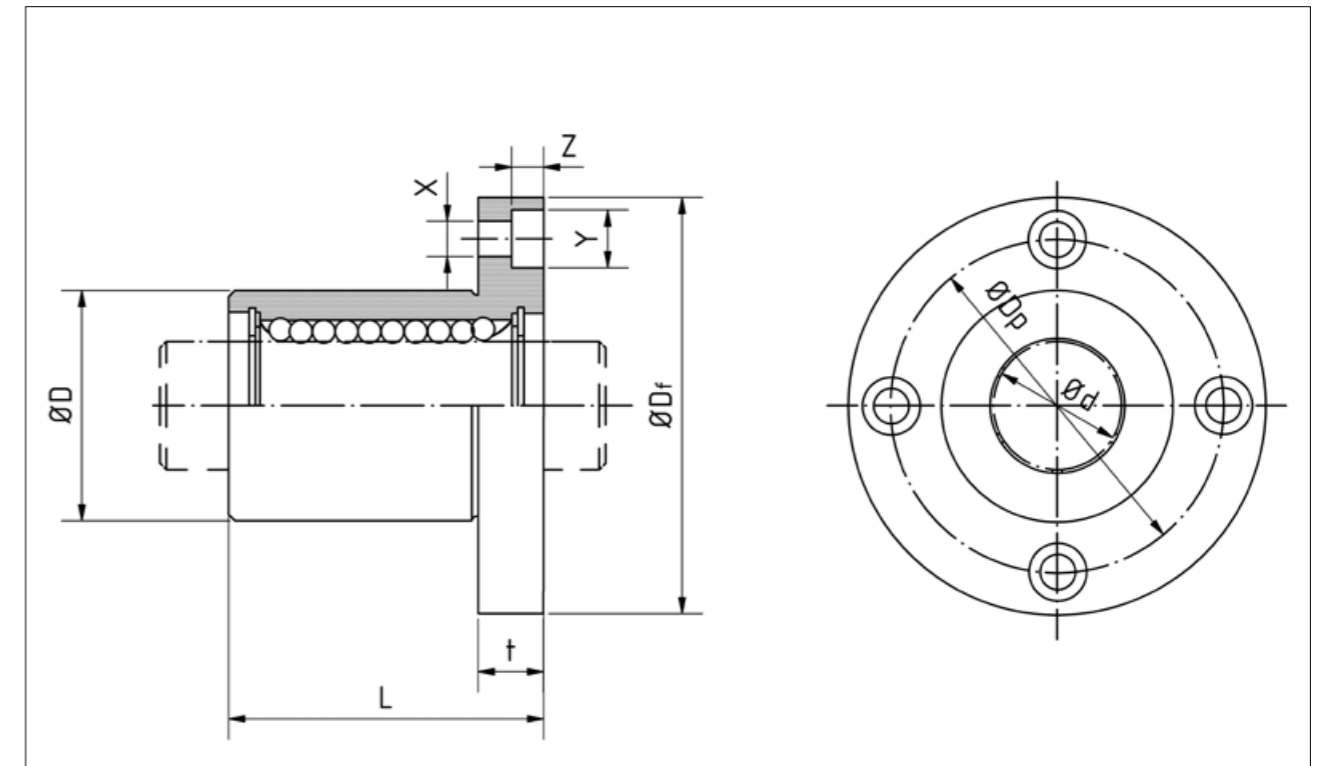

Order reference				Dimensions [mm]								
Standard		Corrosion-resistant		Ød	Tolerance	ØD	Tolerance	L	Tolerance	ØDf	t	ØDp
Plastic cage	Steel cage	Plastic cage	Stainless steel cage									
BBER5	-	BBERS5	-	5	+0,008 0	12	0	22	±0,3	28	5	20
BBER8	BBER8A	BBERS8	BBERS8A	8		16	-0,013	25		32	5	24
BBER12	BBER12A	BBERS12	BBERS12A	12		22	1	32		42	6	32
BBER16	BBER16A	BBERS16	BBERS16A	16	+0,009 -0,001	26	-0,016	36		46	6	36
BBER20	BBER20A	BBERS20	BBERS20A	20	32	0 -0,019	45	54		8	43	
BBER25	BBER25A	BBERS25	BBERS25A	25	+0,011 -0,001		40	58		62	8	51
BBER30	BBER30A	BBERS30	BBERS30A	30	47		68	76		10	62	
BBER40	BBER40A	BBERS40	BBERS40A	40	+0,013 -0,002	62	0	80		98	13	80
BBER50	BBER50A	BBERS50	BBERS50A	50		75	-0,022	100		112	13	94
BBER60	BBER60A	BBERS60	BBERS60A	60		90	0	125		134	18	112
-	BBER80A	-	-	80	+0,016 -0,004	120	-0,025	165	164	18	142	

Dimensions [mm]			Rows of balls	Max. eccentricity [µm]	Angular deviation [µm]	Dynamic load rating [N]	Static load prating [N]	Weight [g]	Order reference			
X	Y	Z							Standard		Corrosion-resistant	
									Plastic cage	Steel cage	Plastic cage	Stainless steel cage
3,5	6	3,1	4	12	12	159	265	26	BBER5	-	BBERS5	-
3,5	6	3,1	4			195	402	41	BBER8	BBER8A	BBERS8	BBERS8A
4,5	7,5	4,1	4			416	784	80	BBER12	BBER12A	BBERS12	BBERS12A
4,5	7,5	4,1	4			432	892	103	BBER16	BBER16A	BBERS16	BBERS16A
5,5	9	5,1	5	15	15	877	1 370	182	BBER20	BBER20A	BBERS20	BBERS20A
5,5	9	5,1	6			908	1 570	335	BBER25	BBER25A	BBERS25	BBERS25A
6,6	11	6,1	6			1 584	2 740	560	BBER30	BBER30A	BBERS30	BBERS30A
9	14	8,1	6	17	17	2 357	4 020	1 175	BBER40	BBER40A	BBERS40	BBERS40A
9	14	8,1	6			4 702	7 940	1 745	BBER50	BBER50A	BBERS50	BBERS50A
11	17	11,1	6	20	20	6 085	9 800	3 220	BBER60	BBER60A	BBERS60	BBERS60A
11	17	11,1	6			9 465	16 000	6 420	-	BBER80A	-	-

The indicated load ratings are applicable in cases where the load only applies to one row of balls. If, however, the force is shared between two rows of balls, the load capacity is increased by the following factor (refer to table on page 75).

Tandem standard ball bushings



The tandem standard ball bushings of the BBE...L series have the same dimensions and tolerances of the ISO standard ball bushings, however they are twice as long and they are applied where high moment load exists.

The big advantage of this type of ball bushings is that two standard ball bushings may be replaced. Since the concentricity is built in, increased accuracy is achieved and manufacturing costs reduced.

The standard ball bushings can be supplied from stock, with two wiper seals. The required seals are to be included when ordering.

Optional relubricable

- Examples of order reference for a ball bushings with single-sided seal: BBE12LU, BBE12LAU
- Examples of order reference for a ball bushings with double-sided seal: BBE12LUU, BBE12LAUU
- Examples of order reference for a ball bushings with double-sided seal, relubricable: BBE12LUU-RL

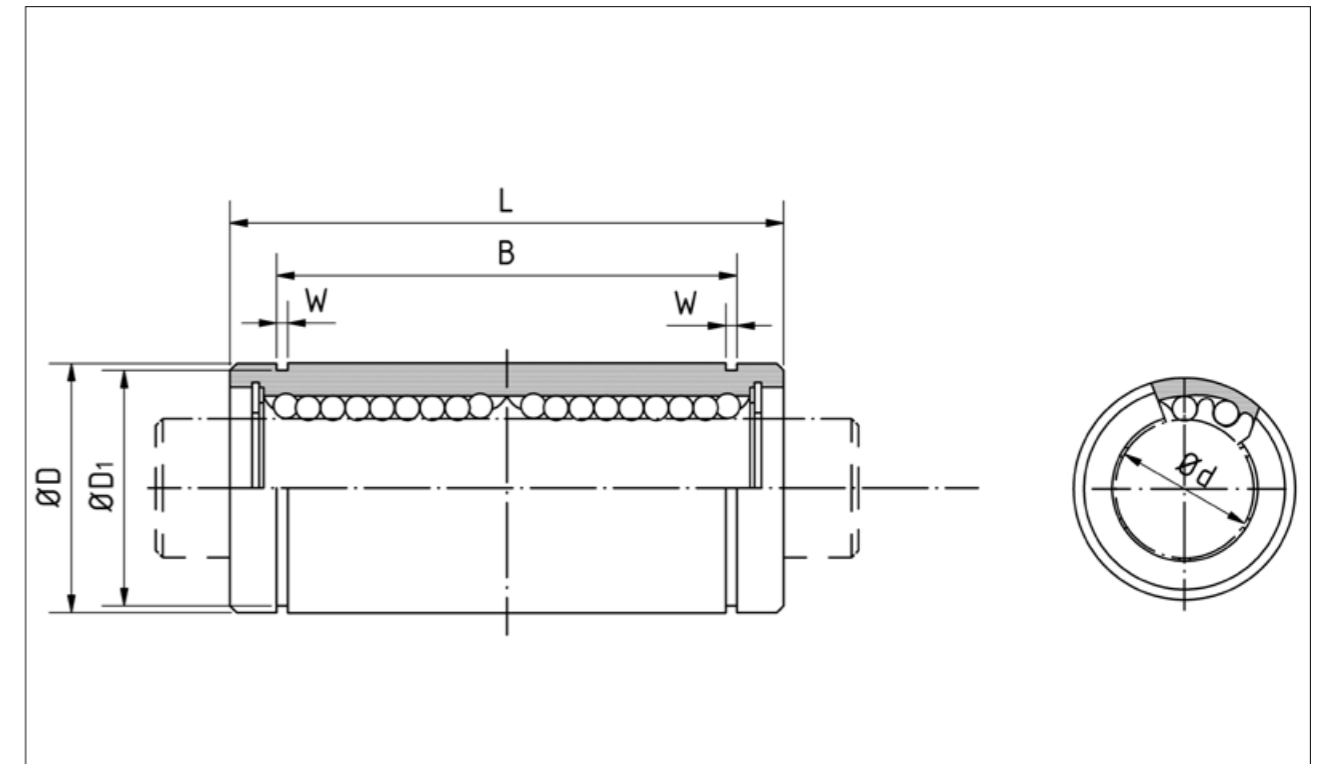

Order reference				Dimensions [mm]							
Standard		Corrosion-resistant		Ød	Tolerance	ØD	Tolerance	L	Tolerance	B	Tolerance
Plastic cage	Steel cage	Plastic cage	Stainless steel cage								
BBE8L	BBE8LA	BBES8L	BBES8LA	8	+0,009 0	16	0 -0,009	46	0 -0,3	33	0 -0,3
BBE12L	BBE12LA	BBES12L	BBES12LA	12	+0,011 -0,001	22	0 -0,011	61		45,8	
BBE16L	BBE16LA	BBES16L	BBES16LA	16		26	68	49,8			
BBE20L	BBE20LA	BBES20L	BBES20LA	20		32	80	61			
BBE25L	BBE25LA	BBES25L	BBES25LA	25	+0,013 -0,002	40	0 -0,013	112	0 -0,4	82	0 -0,4
BBE30L	BBE30LA	BBES30L	BBES30LA	30	47	123	104,2				
BBE40L	BBE40LA	BBES40L	BBES40LA	40	+0,016 -0,004	62	0 -0,015	151		121,2	
BBE50L	BBE50LA	BBES50L	BBES50LA	50		75	192	155,2			
BBE60L	BBE60LA	BBES60L	BBES60LA	60		90	0 -0,020	209		170	

Dimensions [mm]		Rows of balls	Max. eccentricity [µm]	Dynamic load rating [N]	Static load rating [N]	Weight [g]	Order reference			
W	ØD1						Standard		Corrosion-resistant	
							Plastic cage	Steel cage	Plastic cage	Stainless steel cage
1,1	15,2	4	15	320	804	40	BBE8L	BBE8LA	BBES8L	BBES8LA
1,3	21	4		683	1 570	80	BBE12L	BBE12LA	BBES12L	BBES12LA
1,3	24,9	4		710	1 780	115	BBE16L	BBE16LA	BBES16L	BBES16LA
1,6	30,3	5	17	1 440	2 740	180	BBE20L	BBE20LA	BBES20L	BBES20LA
1,85	37,5	6		1 490	3 140	430	BBE25L	BBE25LA	BBES25L	BBES25LA
1,85	44,5	6		2 600	5 490	615	BBE30L	BBE30LA	BBES30L	BBES30LA
2,15	59	6	20	3 872	8 040	1 400	BBE40L	BBE40LA	BBES40L	BBES40LA
2,65	72	6		7 701	15 900	2 320	BBE50L	BBE50LA	BBES50L	BBES50LA
3,15	86,5	6		9 940	20 000	3 920	BBE60L	BBE60LA	BBES60L	BBES60LA

The indicated load ratings are only applicable in cases where the load is being applied to a single row of balls bearing. If, however, the force is shared between two rows of balls, the load capacity is increased by the following factor (refer to table on page 75).

Tandem flanged standard ball bushings (round)



The ball bushings of the BBER...L series combine the advantages of flanged standard ball bushings with those of tandem ball bushings, since they provide a rigid, aligned linear guidance through their length, allowing the application of a second ball bearing.

The standard ball bushings can be supplied from stock, with two wiper seals. The required seals are to be included when ordering.

Optional relubricable

- Examples of order reference for a ball bushings with single-sided seal: BBER12LU, BBER12LAU
- Examples of order reference for a ball bushings with double-sided seal: BBER12LUU, BBER12LAUU
- Examples of order reference for a ball bushings with double-sided seal, relubricable: BBER12LUU-RL

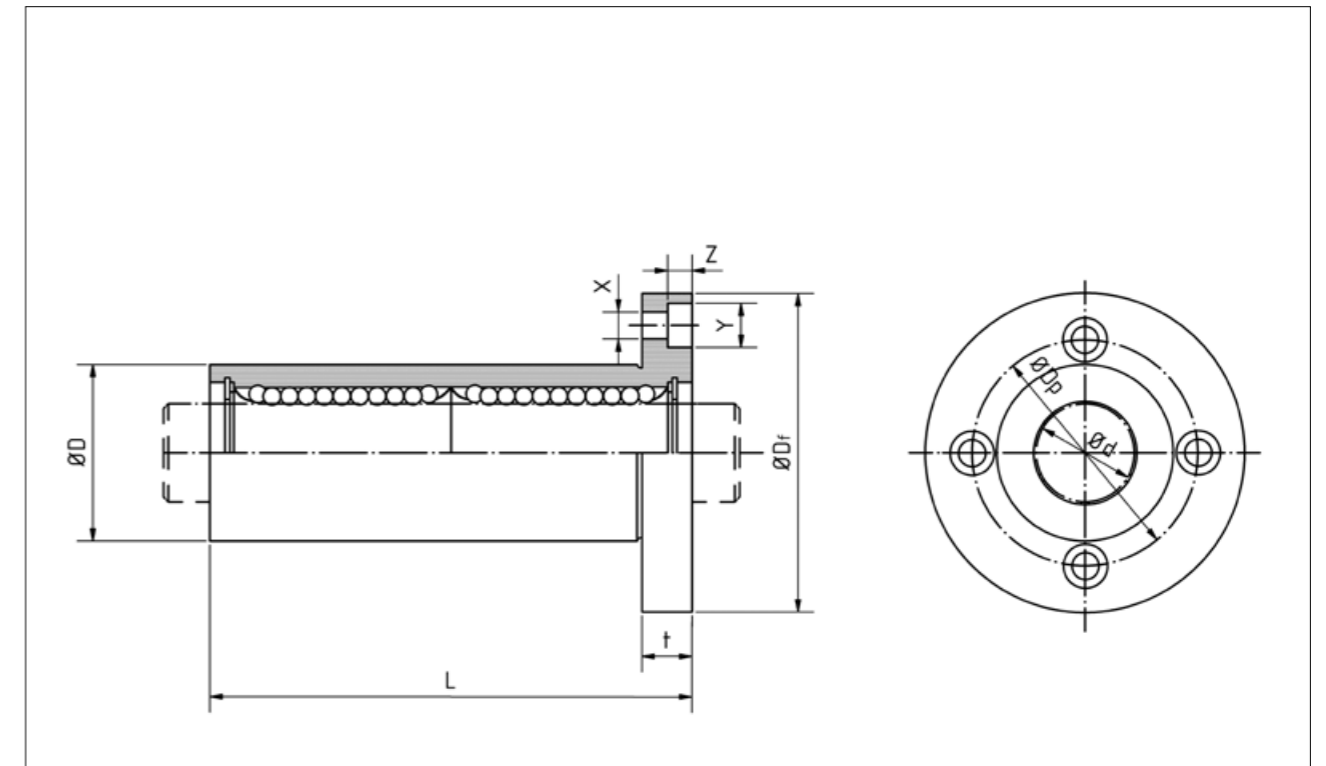

Order reference				Dimensions [mm]								
Standard		Corrosion-resistant		Ød	Tolerance	ØD	Tolerance	L	Tolerance	ØDf	t	ØDp
Plastic cage	Steel cage	Plastic cage	Stainless steel cage									
BBER8L	BBER8LA	BBERS8L	BBERS8LA	8	+0,009 -0,001	16	0 -0,013	46	±0,3	32	5	24
BBER12L	BBER12LA	BBERS12L	BBERS12LA	12	+0,011 -0,001	22	0 -0,016	61		42	6	32
BBER16L	BBER16LA	BBERS16L	BBERS16LA	16		26	68	46		6	36	
BBER20L	BBER20LA	BBERS20L	BBERS20LA	20	32	80	54	8		43		
BBER25L	BBER25LA	BBERS25L	BBERS25LA	25	+0,013 -0,002	40	0 -0,019	112		62	8	51
BBER30L	BBER30LA	BBERS30L	BBERS30LA	30	47	123	76	10		62		
BBER40L	BBER40LA	BBERS40L	BBERS40LA	40	+0,016 -0,004	62	0 -0,022	151		98	13	80
BBER50L	BBER50LA	BBERS50L	BBERS50LA	50		75	192	112		13	94	
BBER60L	BBER60LA	BBERS60L	BBERS60LA	60		90	209	134		18	112	

Dimensions [mm]			Rows of balls	Max. eccentricity [µm]	Angular deviation [µm]	Dynamic load rating [N]	Static load rating [N]	Permissible statical moment My [Nm]	Weight [g]	Order reference			
X	Y	Z								Standard		Corrosion-resistant	
										Plastic cage	Steel cage	Plastic cage	Stainless steel cage
3,5	6	3,1	4	15	15	320	804	4,3	59	BBER8L	BBER8LA	BBERS8L	BBERS8LA
4,5	7,5	4,1	4			683	1 570	12	110	BBER12L	BBER12LA	BBERS12L	BBERS12LA
4,5	7,5	4,1	4			710	1 780	14	160	BBER16L	BBER16LA	BBERS16L	BBERS16LA
5,5	9	5,1	5	17	17	1 440	2 740	25	260	BBER20L	BBER20LA	BBERS20L	BBERS20LA
5,5	9	5,1	6			1 490	3 140	44	540	BBER25L	BBER25LA	BBERS25L	BBERS25LA
6,6	11	6,1	6			2 600	5 490	78	815	BBER30L	BBER30LA	BBERS30L	BBERS30LA
9	14	8,1	6	20	20	3 872	8 040	147	1 805	BBER40L	BBER40LA	BBERS40L	BBERS40LA
9	14	8,1	6			7 701	15 900	396	2 820	BBER50L	BBER50LA	BBERS50L	BBERS50LA
11	17	11,1	6			9 940	20 000	487	4 920	BBER60L	BBER60LA	BBERS60L	BBERS60LA

The indicated load ratings are only applicable in cases where the load is being applied to a single row of balls. If, however, the force is shared between two rows of balls, the load capacity is increased by the following factor (refer to table on page 75).

Middle flanged standard ball bushings (round)

Tandem ball bushings of the BBERM... series with a middle flange are designed specially for applications in which the shafts are perpendicular to the mounting surface. They remove the need for a housing and simplify the installation.



The standard ball bushings can be supplied from stock, with two wiper seals. The required seals are to be included when ordering.

Optional relubricable

- Examples of order reference for a ball bushings with single-sided seal: BBERM12U, BBERM12AU
- Examples of order reference for a ball bushings with double-sided seal: BBERM12UU, BBERM12AAU

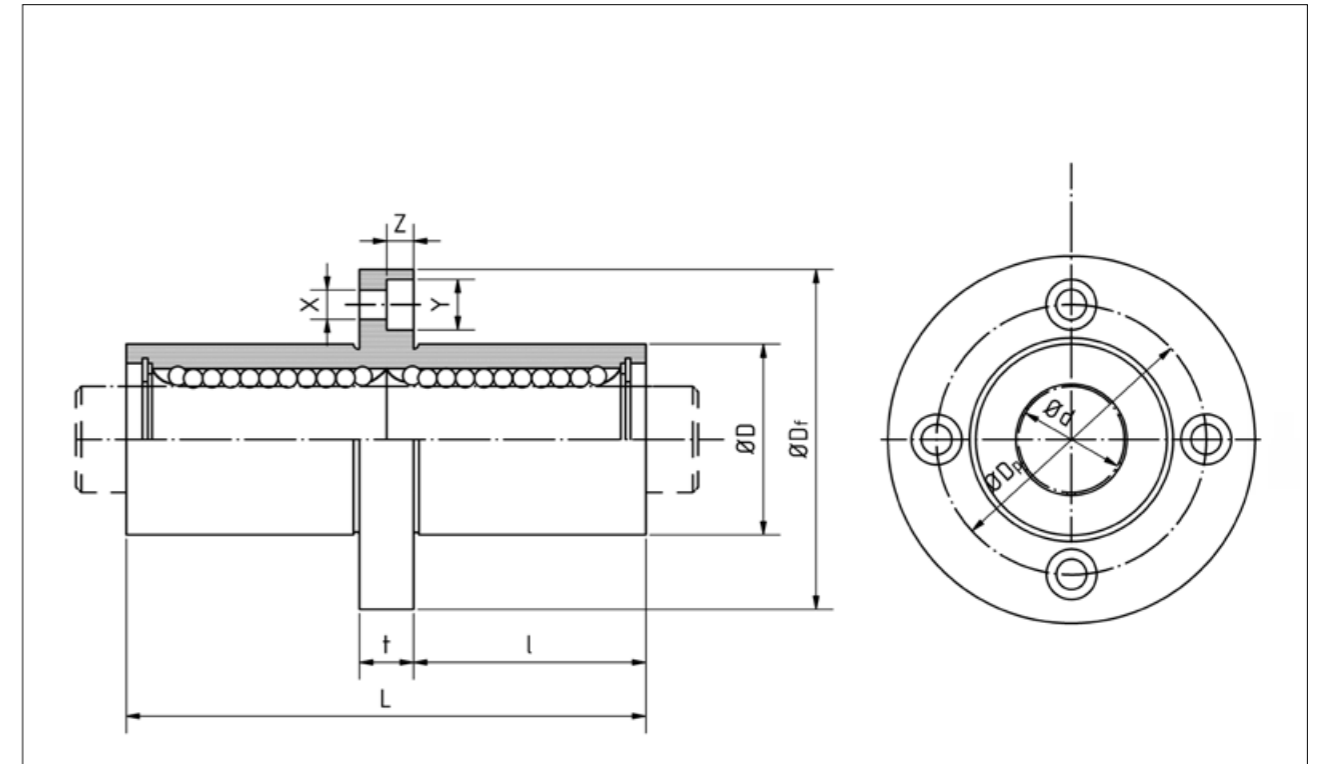

Order reference				Dimensions [mm]									
Standard		Corrosion-resistant		Ød	Tolerance	ØD	Tolerance	L	Tolerance	l	ØDf	t	ØDp
Plastic cage	Steel cage	Plastic cage	Stainless steel cage										
BBERM8	BBERM8A	BBERMS8	BBERMS8A	8	+0,009 -0,001	16	0 -0,013	46	±0,3	20,5	32	5	24
BBERM12	BBERM12A	BBERMS12	BBERMS12A	12	+0,011 -0,001	22	0 -0,016	61		27,5	42	6	32
BBERM16	BBERM16A	BBERMS16	BBERMS16A	16		26	0 -0,019	68		31	46	6	36
BBERM20	BBERM20A	BBERMS20	BBERMS20A	20	32	80		36		54	8	43	
BBERM25	BBERM25A	BBERMS25	BBERMS25A	25	+0,013 -0,002	40	0 -0,022	112		52	62	8	51
BBERM30	BBERM30A	BBERMS30	BBERMS30A	30	47	123		56,5		76	10	62	
BBERM40	BBERM40A	BBERMS40	BBERMS40A	40	+0,016 -0,004	62	0	151		69	98	13	80
BBERM50	BBERM50A	BBERMS50	BBERMS50A	50		75	192	89,5		112	13	94	
BBERM60	BBERM60A	BBERMS60	BBERMS60A	60		90	209	95,5		134	18	112	

Dimensions [mm]			Rows of balls	Max. eccentricity [µm]	Angular deviation [µm]	Dynamic load rating [N]	Static load prating [N]	Permissible statical moment My [Nm]	Weight [g]	Order reference			
X	Y	Z								Standard		Corrosion-resistant	
										Plastic cage	Steel cage	Plastic cage	Stainless steel cage
3,5	6	3,1	4	15	15	320	804	4,3	59	BBERM8	BBERM8A	BBERMS8	BBERMS8A
4,5	7,5	4,1	4			683	1 570	11,7	110	BBERM12	BBERM12A	BBERMS12	BBERMS12A
4,5	7,5	4,1	4			710	1 780	14,2	160	BBERM16	BBERM16A	BBERMS16	BBERMS16A
5,5	9	5,1	5	17	17	1 440	2 740	25	260	BBERM20	BBERM20A	BBERMS20	BBERMS20A
5,5	9	5,1	6			1 490	3 140	44	540	BBERM25	BBERM25A	BBERMS25	BBERMS25A
6,6	11	6,1	6			2 600	5 490	78,9	815	BBERM30	BBERM30A	BBERMS30	BBERMS30A
9	14	8,1	6	20	20	3 872	8 040	147	1 805	BBERM40	BBERM40A	BBERMS40	BBERMS40A
9	14	8,1	6			7 701	15 900	396	2 820	BBERM50	BBERM50A	BBERMS50	BBERMS50A
11	17	11,1	6			9 940	20 000	487	4 920	BBERM60	BBERM60A	BBERMS60	BBERMS60A

The indicated load ratings are only applicable in cases where the load is being applied to a single row of balls. If, however, the force is shared between two rows of balls, the load capacity is increased by the following factor (refer to table on page 75).

JIS dimensions

Ball bushings, closed

Closed ball bushings of the BB series, according to JIS (Metric series, Asian dimensions).



The ball bushings with the order reference printed in **bold** are available ex stock. The required seals are to be included when ordering.

Optional relubricable

- Examples of order reference for a ball bushings with single-sided seal: BB12U, BB12AU
- Examples of order reference for a ball bushings with double-sided seal: BB12UU, BB12AAU
- Examples of order reference for a ball bushings with double-sided seal, relubricable: BB12UU-RL

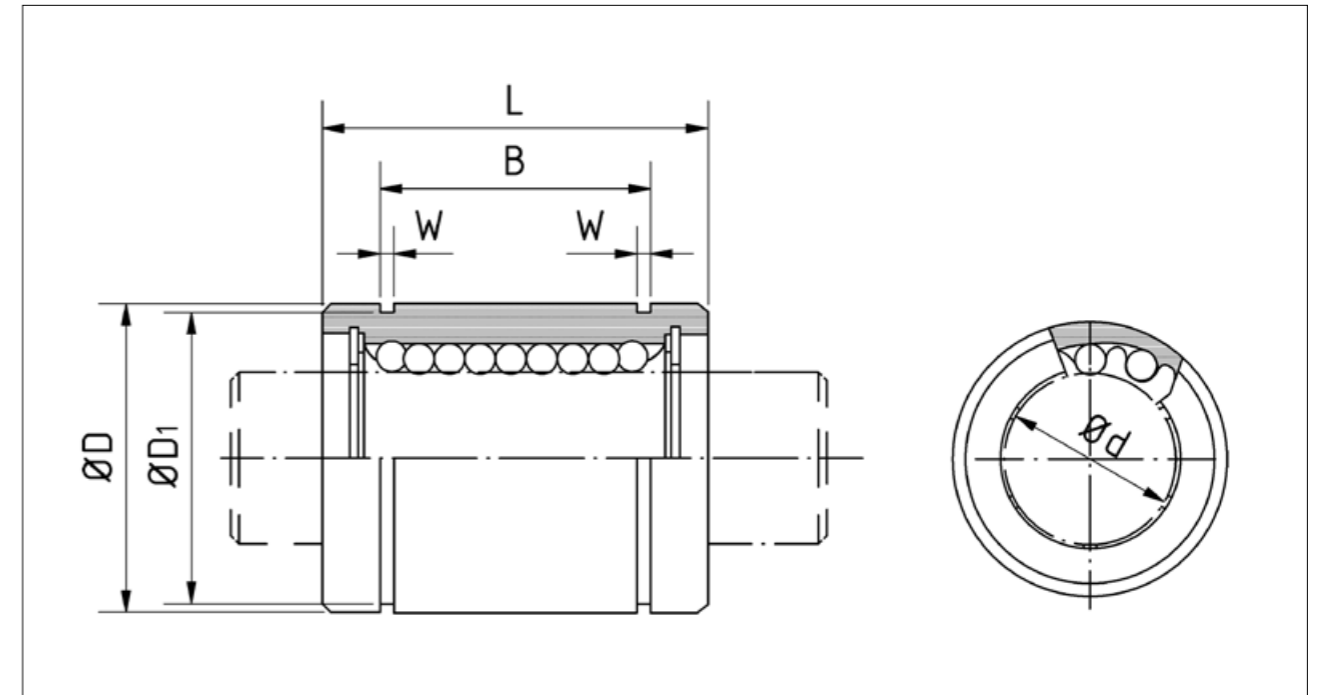

Order reference				Dimensions [mm]									
Standard		Corrosion-resistant		Ød	Tolerance	ØD	Tolerance	L	Tolerance	B	Tolerance	W	ØD1
Plastic cage	Steel cage	Plastic cage	Stainless steel cage										
BB3	BB3A	BBS3	BBS3A	3		7		10		-		-	-
BB4	BB4A	BBS4	BBS4A	4	0 -0,008	8	0 -0,009	12	0 -0,12	-		-	-
BB5	BB5A	BBS5	BBS5A	5		10		15		10,2		1,1	9,6
BB6	BB6A	BBS6	BBS6A	6		12		19		13,5		1,1	11,5
BB8s	BB8sA	BBS8s	BBS8sA	8		15	0 -0,011	17		11,5		1,1	14,3
BB8	BB8A	BBS8	BBS8A	8		15		24		17,5		1,1	14,3
BB10	BB10A	BBS10	BBS10A	10	0 -0,009	19		29	0 -0,2	22		1,3	18
BB12	BB12A	BBS12	BBS12A	12		21	0 -0,013	30		23		1,3	20
BB13	BB13A	BBS13	BBS13A	13		23		32		23		1,3	22
BB16	BB16A	BBS16	BBS16A	16		28		37		26,5		1,6	27
BB20	BB20A	BBS20	BBS20A	20		32		42		30,5		1,6	30,5
BB25	BB25A	BBS25	BBS25A	25	0 -0,010	40	0 -0,016	59		41		1,85	38
BB30	BB30A	BBS30	BBS30A	30		45		64		44,5		1,85	43
BB35	BB35A	BBS35	BBS35A	35		52		70	0 -0,3	49,5	0 -0,3	2,1	49
BB40	BB40A	BBS40	BBS40A	40	0 -0,012	60	0 -0,019	80		60,5		2,1	57
BB50	BB50A	BBS50	BBS50A	50		80		100		74		2,6	76,5
BB60	BB60A	BBS60	BBS60A	60	0 -0,015	90	0 -0,022	110		85		3,15	86,5
BB80	BB80A	BBS80	BBS80A	80		120		140		105,5		4,15	116
-	BB100A	-	-	100	0 -0,020	150	0 -0,025	175	0 -0,4	125,5	0 -0,4	4,15	145
-	BB120A	-	-	120		180		200		158,6		4,15	175
-	BB150A	-	-	150	0 -0,025	210	0 -0,029	240		170,6		5,15	204

Rows of balls	Max. eccentricity [µm]	Max. radial clearance [µm]	Dynamic load rating [N]	Static load rating [N]	Weight [g]	Order reference			
						Standard		Corrosion-resistant	
						Plastic cage	Steel cage	Plastic cage	Stainless steel cage
4	8	-3	44	105	1,4	BB3	BB3A	BBS3	BBS3A
4			47	127	2	BB4	BB4A	BBS4	BBS4A
4			82	206	4	BB5	BB5A	BBS5	BBS5A
4			131	265	8,5	BB6	BB6A	BBS6	BBS6A
4	12	-3	153	216	11	BB8s	BB8sA	BBS8s	BBS8sA
4			194	392	17	BB8	BB8A	BBS8	BBS8A
4			286	594	36	BB10	BB10A	BBS10	BBS10A
4			415	784	42	BB12	BB12A	BBS12	BBS12A
4	15	-4	421	784	49	BB13	BB13A	BBS13	BBS13A
4			676	1 180	76	BB16	BB16A	BBS16	BBS16A
5			792	1 370	100	BB20	BB20A	BBS20	BBS20A
6			1 073	1 570	240	BB25	BB25A	BBS25	BBS25A
6	20	-6	1 584	2 740	270	BB30	BB30A	BBS30	BBS30A
6			1 875	3 140	425	BB35	BB35A	BBS35	BBS35A
6			2 357	4 020	654	BB40	BB40A	BBS40	BBS40A
6			4 702	7 940	1 700	BB50	BB50A	BBS50	BBS50A
6	25	-8	5 606	10 000	2 000	BB60	BB60A	BBS60	BBS60A
6			10 347	16 000	4 520	BB80	BB80A	BBS80	BBS80A
6			17 323	34 800	8 600	-	BB100A	-	-
8			24 571	40 000	15 000	-	BB120A	-	-
8	30	-10	33 701	54 300	20 250	-	BB150A	-	-
8			40	-13					

The indicated load ratings are only applicable in cases where the load is being applied to a single row of balls. If, however, the force is shared between two rows of balls, the load capacity is increased by the following factor (refer to table on page 75).

Super ball bushings (closed, open)

The super ball bushings of the BBET series according to ISO 10285 are available as an open and a closed model. The super ball bushings have similar dimensions and tolerances as standard ball bushings.

Super ball bushings have crowned track segments which allow misalignments of up to 0.5° to be accommodated. Hence, overloading because of bending (deflection) of the shaft or skew due to inaccuracies of the tooling hole is avoided.

Through the specific construction, higher capacities, smoother operation, as well as a higher permissible operating speed of up to 3 m/s, are obtained.

Because of the self-adjustment, per shaft, at least two super ball bushings should be utilized to avoid tilting.



The super ball bushings can be supplied from stock, with two wiper seals.

- Examples of order reference for a ball bushings with double-sided seal: BBET12UU, BBET12UU-OP

Order reference		Dimensions [mm]									
Closed	Open	Ødr	Tolerance	ØD	L	Tolerance	L1	Tolerance	L2	ØD1	h
BBET8	-	8	+0,008 0	16	25	±0,2	16,5	0 -0,2	1,1	15,2	-
BBET10	-	10		19	29		22		1,3	18	-
BBET12	BBET12-OP	12		22	32		22,9		1,3	21	6,5
BBET16	BBET16-OP	16	+0,009 0,001	26	36	24,9	1,3	24,9	9		
BBET20	BBET20-OP	20		32	45	31,5	1,6	30,3	9		
BBET25	BBET25-OP	25		40	58	44,1	1,85	37,5	11,5		
BBET30	BBET30-OP	30	+0,011 0,001	47	68	52,1	1,85	44,5	14		
BBET40	BBET40-OP	40		62	80	60,6	2,15	59	19,5		
BBET50	BBET50-OP	50		75	100	77,6	2,65	72	22,5		

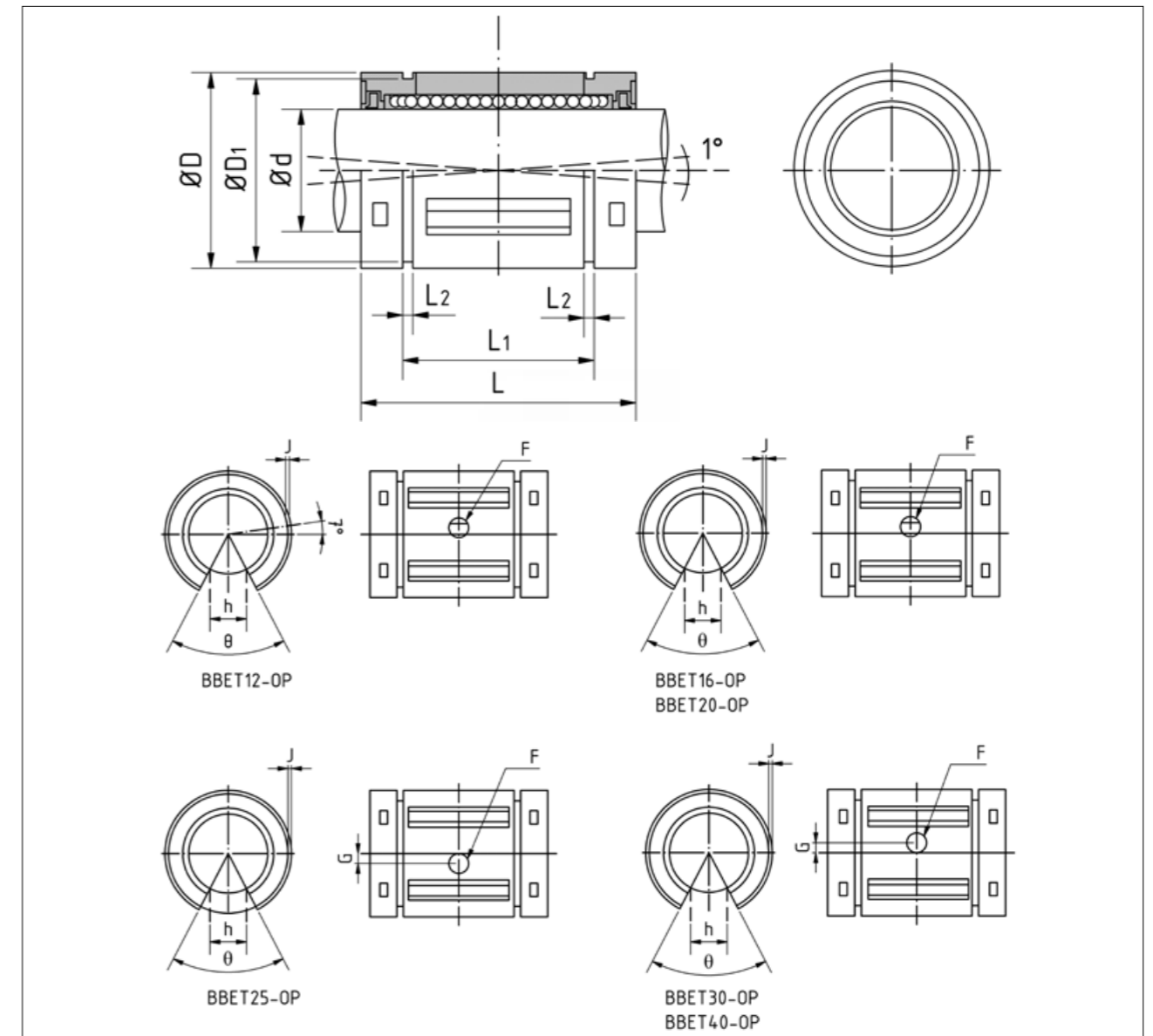

Dimensions [mm]				Rows of balls		Dynamic load rating [N]	Static load rating [N]	Weight [g]		Order reference		
θ [°]	F H11	G	J	Closed	Open			Closed	Open	Closed	Open	
-	-	-	-	4	-	423	534	7,3	-	BBET8	-	
-	-	-	-	5	-	750	935	14	-	BBET10	-	
66	3	-	0,7	5	4	1 020	1 290	21	17	BBET12	BBET12-OP	
68		-	1	5	4	1 250	1 550	43	35	BBET16	BBET16-OP	
55		-	1	6	5	2 090	2 630	58	48	BBET20	BBET20-OP	
57		1,5	1,5	6	5	3 780	4 720	123	103	BBET25	BBET25-OP	
57		2	1,7	6	5	5 470	6 810	216	177	BBET30	BBET30-OP	
56		1,5	2,4	6	5	6 590	8 230	333	275	BBET40	BBET40-OP	
54		5	2,5	2,7	6	5	10 800	13 500	618	520	BBET50	BBET50-OP

The indicated load ratings are only applicable in cases where the load is being applied to a single row of balls. If, however, the force is shared between two rows of balls, the load capacity is increased by the following factor (refer to table on page 75).

Ball sleeves KH Series

The ball sleeves of the KH series are compact linear ball bearings with small dimensions similar to sleeve bearings.

The balls, circulating in the retainer pass via openings in the outer sleeve, allowing relubrication.



The ball sleeves with the order reference printed in **bold** are also available with two wiper seals. The required seals are to be included when ordering.

- Examples of order reference for a ball bushings with double-sided seal:
KH1228LL/3AS

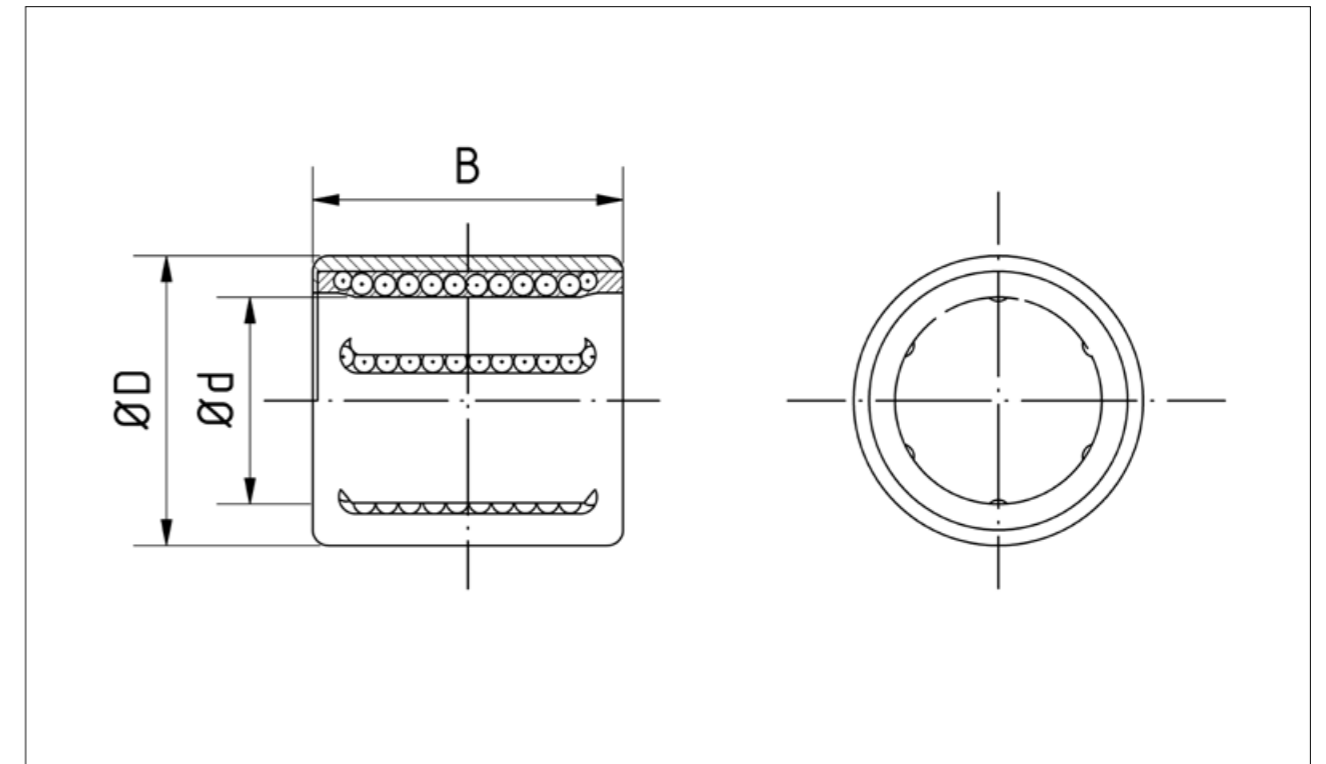

Order reference	Dimensions [mm]			Rows of ball bushings	Dynamic load rating [N]	Static load rating [N]	Weight [g]
	Ød	ØD	B				
KH1228	12	19	28	5	605	495	18
KH1428	14	21	28	5	600	505	21
KH1630	16	24	30	5	775	600	27
KH2030	20	28	30	6	1 050	880	33
KH2540	25	35	40	6	1 930	1 560	66
KH3050	30	40	50	7	2 700	2 450	95
KH4060	40	52	60	8	4 250	4 000	180
KH5070	50	62	70	9	5 300	5 700	240

Linear units with standard ball bushings, relubrication

Linear units with standard ball bushings

Closed casing

Due to their optimised design, the linear units of the LSE series with a relubrication system offer high precision in any type of installation.

A LSE linear unit consists of the following:

- Casing (AlMgSi0,5)
- BBE standard ball bushings
- Wiper seals made from NBR

The linear units offer substantial cost advantages to the user, because of reduced construction expense.

The unit construction allows easier integration into installations. Reduced unit weight is obtained by using high grade aluminium, allowing for greater accelerations and higher speeds.

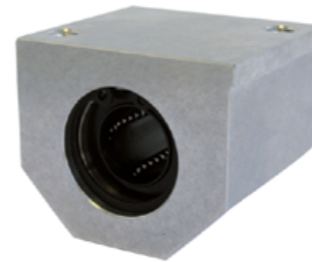

Order reference	Dimensions [mm]										
	Ød	ØD H6	H	+0,01 -0,02	W	L +0,3	F	G	Y	B	C
LSE12UU	12	22	18		43	39	35	25	10	32	23
LSE16UU	16	26	22		53	43	42	30	12	40	26
LSE20UU	20	32	25		60	54	50	34	13	45	32
LSE25UU	25	40	30		78	67	60	40	15	60	40
LSE30UU	30	47	35		87	79	70	48	16	68	45
LSE40UU	40	62	45		108	91	90	60	20	86	58

Dimensions [mm]				Dynamic load rating [N]	Static load rating [N]	Weight [g]	Order reference
M	P	K	S				
M5	8	11	4,2	416	784	175	LSE12UU
M6	10	13	5,2	432	892	260	LSE16UU
M8	11	18	6,8	877	1 370	442	LSE20UU
M10	15	22	8,6	908	1 570	885	LSE25UU
M10	15	22	8,6	1 584	2 740	1330	LSE30UU
M12	18	26	10,3	2 357	4 020	2 570	LSE40UU

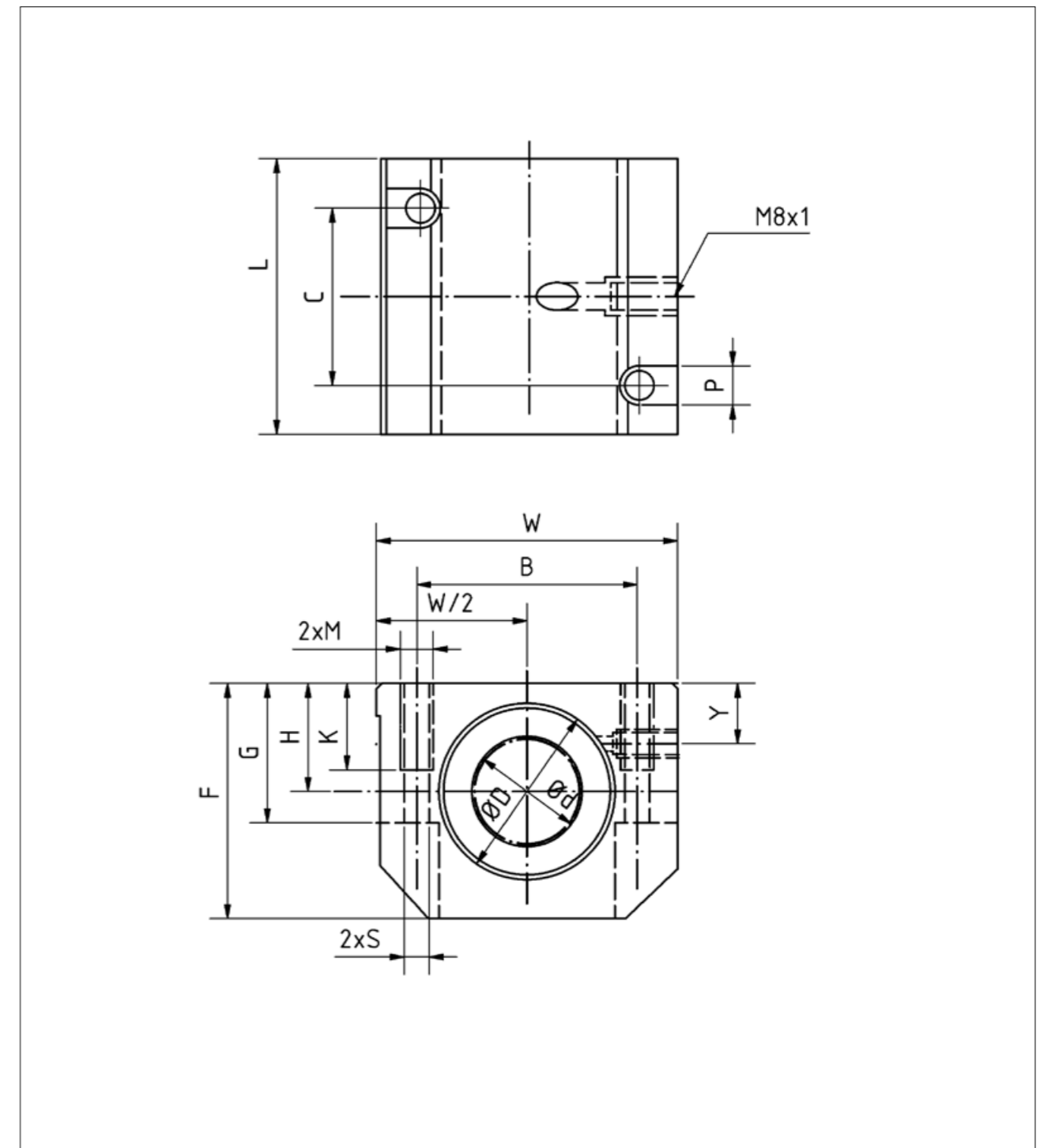

Linear units with standard ball bushings

Closed casing and adjustable clearance

The LSE...-AJ series of linear units are used where guidance with pretension or without play is required.

An adjusting screw allows the radial clearance to be set.

A LSE...-AJ linear unit consists of the following:

- Casing (AlMgSi0,5)
- BBE...-AJ standard ball bushings
- Wiper seals made from NBR

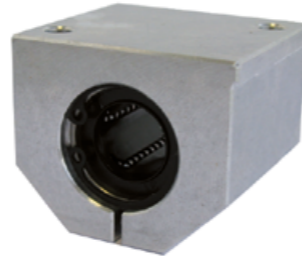

Order reference	Dimensions [mm]										
	Ød	ØD H6	H +0,01 -0,02	W	L +0,3	F	G	Y	B	C	
LSE12UU-AJ	12	22	18	43	39	35	25	10	32	23	
LSE16UU-AJ	16	26	22	53	43	42	30	12	40	26	
LSE20UU-AJ	20	32	25	60	54	50	34	13	45	32	
LSE25UU-AJ	25	40	30	78	67	60	40	15	60	40	
LSE30UU-AJ	30	47	35	87	79	70	48	16	68	45	
LSE40UU-AJ	40	62	45	108	91	90	60	20	86	58	

Dimensions [mm]				Dynamic load rating [N]	Static load rating [N]	Weight [g]	Order reference
M	P	K	S				
M5	8	11	4,2	416	784	175	LSE12UU-AJ
M6	10	13	5,2	432	892	260	LSE16UU-AJ
M8	11	18	6,8	877	1 370	442	LSE20UU-AJ
M10	15	22	8,6	908	1 570	885	LSE25UU-AJ
M10	15	22	8,6	1 584	2 740	1 330	LSE30UU-AJ
M12	18	26	10,3	2 357	4 020	2 570	LSE40UU-AJ

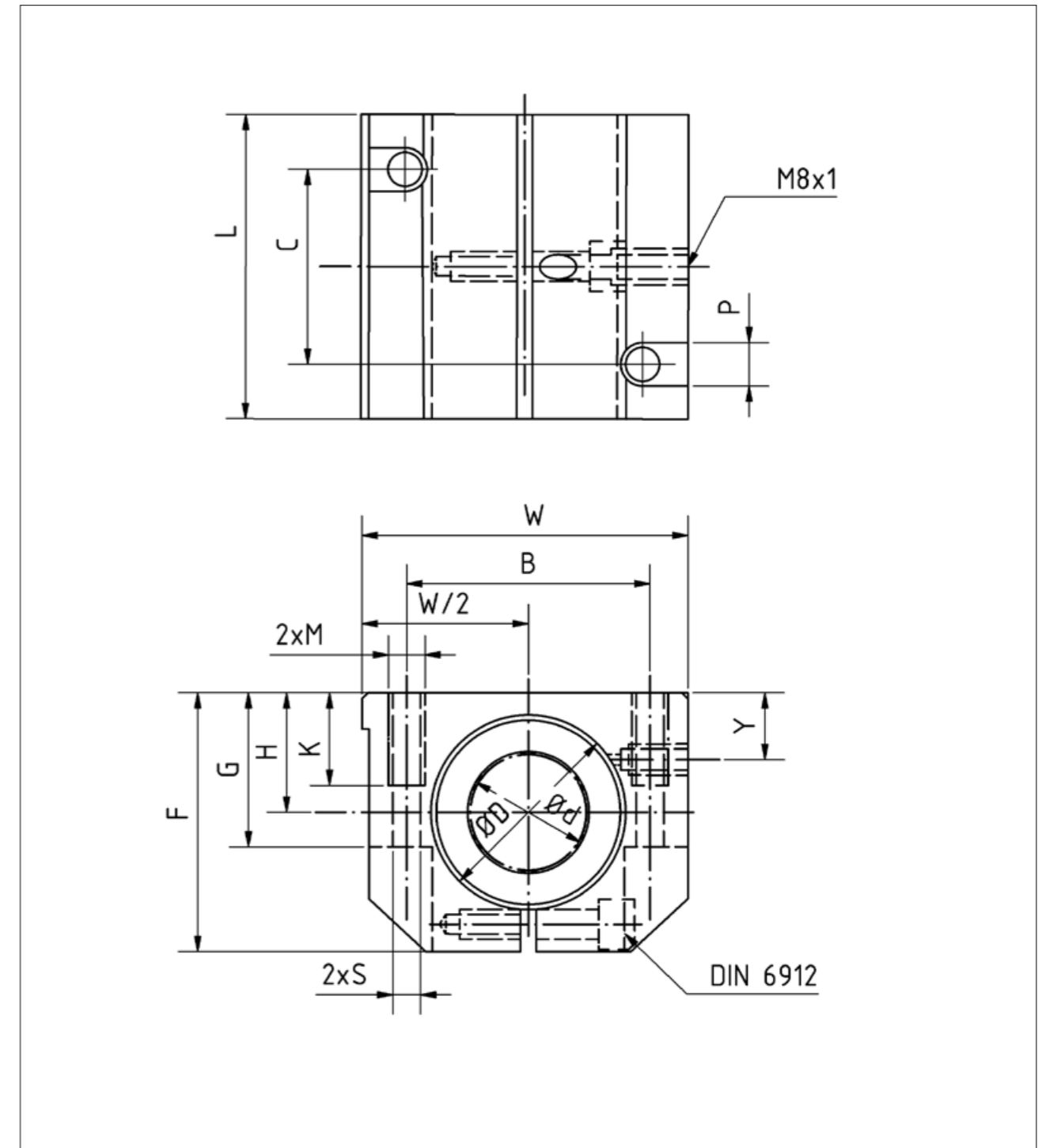

Linear units with standard ball bushings

Open casing

The LSE...-OP series of linear units are used on long shafts which are fully supported. These linear units provide high rigidity and their unit construction allows easier integration into an installation.



A LSE...-OP linear unit consists of the following:

- Casing (AlMgSi0,5)
- BBE...-OP standard ball bushings
- Wiper seals made from NBR

Order reference	Dimensions [mm]										
	Ød	ØD H6	H	+0,01 -0,02	W	L +0,3	F	G	Y	T	B
LSE12UU-OP	12	22	18		43	39	28	23,5	8	16,65	32
LSE16UU-OP	16	26	22		53	43	35	30	12	22	40
LSE20UU-OP	20	32	25		60	54	42	34	13	25	45
LSE25UU-OP	25	40	30		78	67	51	40	15	31,5	60
LSE30UU-OP	30	47	35		87	79	60	48	16	33	68
LSE40UU-OP	40	62	45		108	91	77	60	20	43,5	86

Dimensions [mm]						Dynamic load rating [N]	Static load rating [N]	Weight [g]	Order reference
C	M	P	K	S	R +0,6				
23	M5	8	11	4,2	7	416	784	145	LSE12UU-OP
26	M6	10	13	5,2	9,4	432	892	218	LSE16UU-OP
32	M8	11	18	6,8	10,2	877	1 370	384	LSE20UU-OP
40	M10	15	22	8,6	12,5	908	1 570	765	LSE25UU-OP
45	M10	15	22	8,6	13,9	1 584	2 740	1 170	LSE30UU-OP
58	M12	18	26	10,3	18	2 357	4 020	2 265	LSE40UU-OP

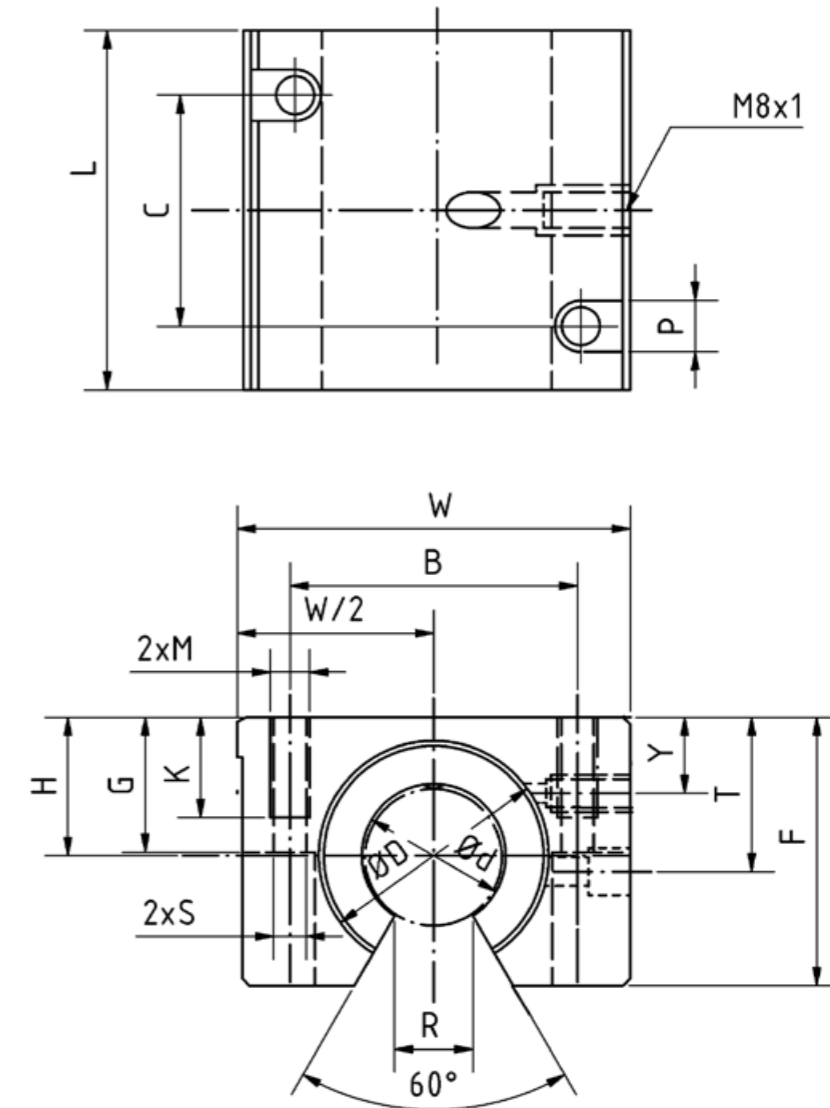

Linear units with standard ball bushings

Open casing and adjustable clearance

The LSE...-AO series of linear units are used where guidance with pre-tension or without play is required.

An adjusting screw allows the radial clearance to be set.

A LSE...-AO linear unit consists of the following:

- Casing (AlMgSi0,5)
- BBE...-OP standard ball bushings
- Wiper seals made from NBR

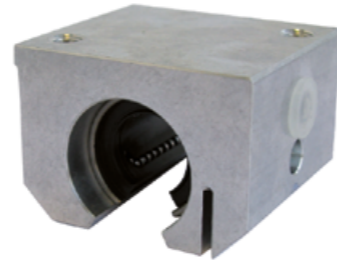

Order reference	Dimensions [mm]										
	Ød	ØD H6	H +0,01 -0,02	W	L +0,3	F	G	Y	T	B	
LSE12UU-AO	12	22	18	43	39	28	25	8	16,65	32	
LSE16UU-AO	16	26	22	53	43	35	30	12	22	40	
LSE20UU-AO	20	32	25	60	54	42	34	13	25	45	
LSE25UU-AO	25	40	30	78	67	51	40	15	31,5	60	
LSE30UU-AO	30	47	35	87	79	60	48	16	33	68	
LSE40UU-AO	40	62	45	108	91	77	60	20	43,5	86	

Dimensions [mm]						Dynamic load rating [N]	Static load rating [N]	Weight [g]	Order reference
C	M	P	K	S	R +0,6				
23	M5	8	11	4,2	7	416	784	145	LSE12UU-AO
26	M6	10	13	5,2	9,4	432	892	218	LSE16UU-AO
32	M8	11	18	6,8	10,2	877	1 370	384	LSE20UU-AO
40	M10	15	22	8,6	12,5	908	1 570	765	LSE25UU-AO
45	M10	15	22	8,6	13,9	1 584	2 740	1 170	LSE30UU-AO
58	M12	18	26	10,3	18	2 357	4 020	2 265	LSE40UU-AO

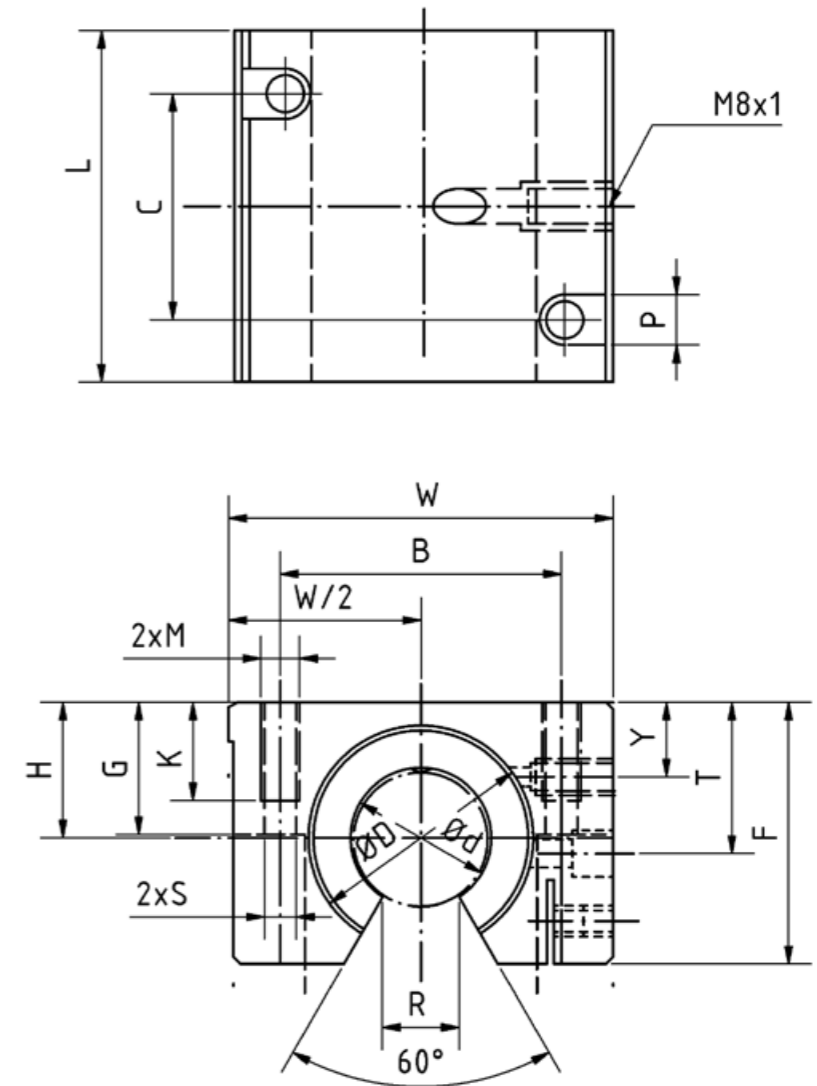

Linear units with standard ball bushings

Casing at one side

Normally, with the open ball bushings design, if the load is applied against the 'open direction', substantial reductions in the load capacity occur. The linear units of the LSE...-SOP series are designed to handle forces in all directions, without a reduction in the load capacity.

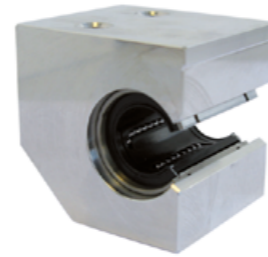

A LSE...-SOP linear unit consists of the following:

- Casing (AlMgSi0,5)
- BBE...-OP standard ball bushings
- Wiper seals made from NBR

Order reference	Dimensions [mm]									
	Ød	ØD H6	H ±0,015	W	L +0,3	F	G	T +0,02 -0,02	C	
LSE20UU-SOP	20	32	30	60	54	60	42	17	30	
LSE25UU-SOP	25	40	35	75	67	72	50	21	36	
LSE30UU-SOP	30	47	40	86	79	82	55	25	42	
LSE40UU-SOP	40	62	45	110	91	100	67	32	48	

Dimensions [mm]						Dynamic load rating [N]	Static load rating [N]	Weight [g]	Order reference
M	K	S	R +0,6	X	Y				
M10	22	8,6	10,2	23,5	32	877	1 370	504	LSE20UU-SOP
M12	26	10,3	12,5	29	38	908	1 570	995	LSE25UU-SOP
M16	34	13,5	13,9	34	44	1 584	2 740	1 510	LSE30UU-SOP
M20	43	17,5	18	40	50	2 357	4 020	2 665	LSE40UU-SOP

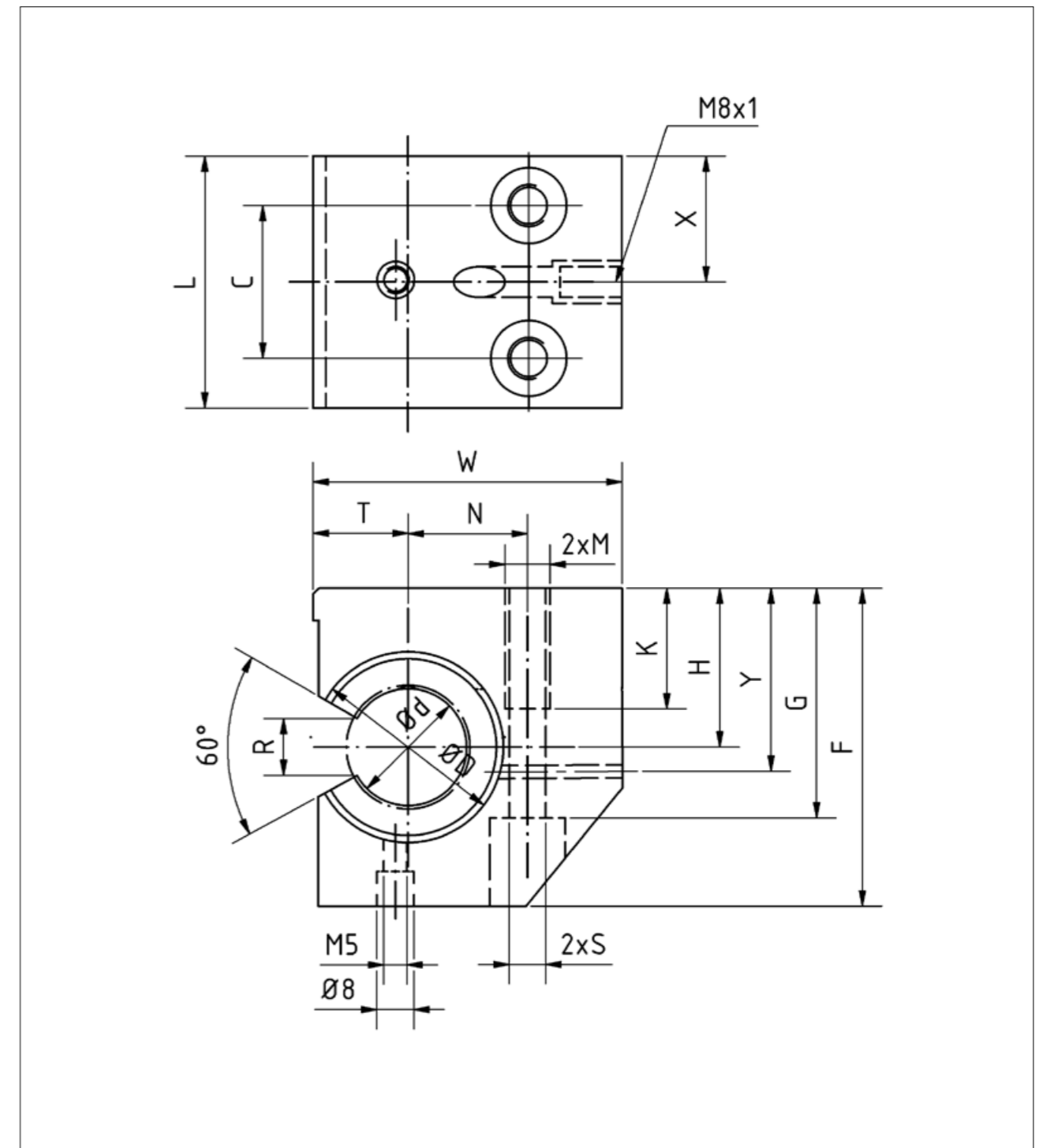

Linear units with standard ball bushings

Casing open on one side and adjustable clearance



Normally, with the open ball bushings design, if the load is applied against the 'open direction', substantial reductions in the load capacity occur. The linear units of the LSE...-SAO series are designed to handle forces in all directions, without a reduction in the load capacity. Radial clearance can be set by means of an adjusting screw.

A LSE...-SAO linear unit consists of the following:

- Casing (AlMgSi0,5)
- BBE...-OP standard ball bushings
- Wiper seals made from NBR

Order reference	Dimensions [mm]									
	Ød	ØD H6	H ±0,015	W	L +0,3	F	G	T ±0,02	C	
LSE20UU-SAO	20	32	30	60	54	60	42	17	30	
LSE25UU-SAO	25	40	35	75	67	72	50	21	36	
LSE30UU-SAO	30	47	40	86	79	82	55	25	42	
LSE40UU-SAO	40	62	45	110	91	100	67	32	48	

Dimensions [mm]						Dynamic load rating [N]	Static load rating [N]	Weight [g]	Order reference
M	K	S	R +0,6	X	Y				
M10	22	8,6	10,2	23,5	32	877	1 370	504	LSE20UU-SAO
M12	26	10,3	12,5	29	38	908	1 570	995	LSE25UU-SAO
M16	34	13,5	13,9	34	44	1 584	2 740	1 510	LSE30UU-SAO
M20	43	17,5	18	40	50	2 357	4 020	2 665	LSE40UU-SAO

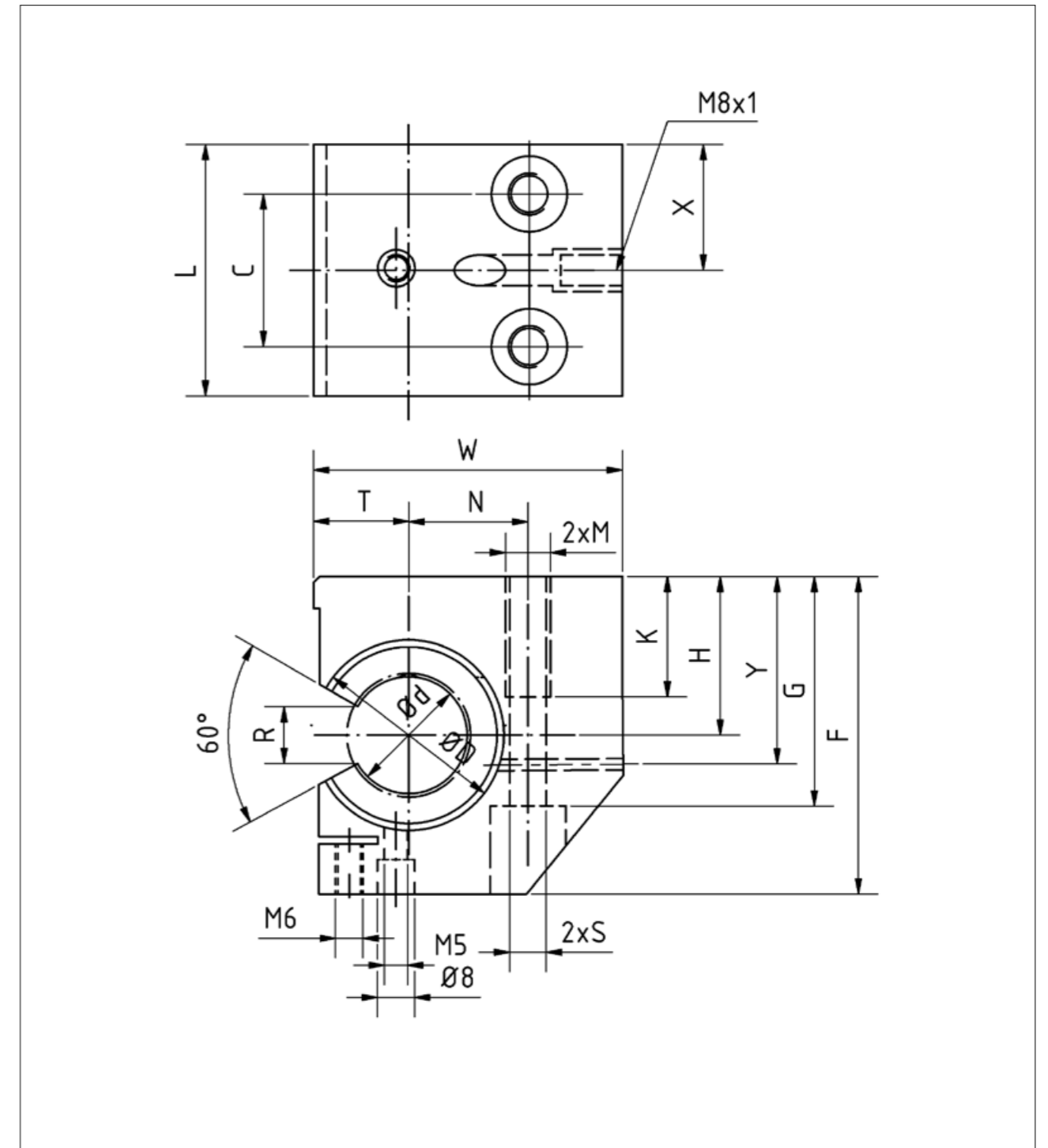

Tandem linear units with standard ball bushings

Closed casing

The tandem linear units of the LSE...L series are twice as long as those of the LSE series. They can be utilized in applications where high moment loads exist.

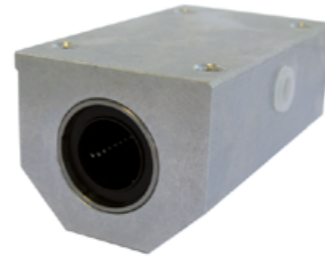

A LSE...L linear unit consists of the following:

- Casing (AlMgSi0,5)
- Two standard BBE ball bushings
- Wiper seals made from NBR

Order reference	Dimensions [mm]									
	Ød	ØD H6	H	+0,01 -0,02	W	L +0,3	F	G	B	C
LSE12LUU	12	22	18		43	76	35	25	32	56
LSE16LUU	16	26	22		53	84	42	30	40	64
LSE20LUU	20	32	25		60	104	50	34	45	76
LSE25LUU	25	40	30		78	130	60	40	60	94
LSE30LUU	30	47	35		87	152	70	48	68	106
LSE40LUU	40	62	45		108	176	90	60	86	124

Dimensions [mm]				Dynamic load rating [N]	Static load rating [N]	Weight [g]	Order reference
M	P	K	S				
M5	8	11	4,2	683	1 570	360	LSE12LUU
M6	10	13	5,2	710	1 780	530	LSE16LUU
M8	11	18	6,8	1 440	2 740	920	LSE20LUU
M10	15	22	8,6	1 490	3 140	1 820	LSE25LUU
M10	15	22	8,6	2 600	5 490	2 730	LSE30LUU
M12	18	26	10,3	3 872	8 040	5 210	LSE40LUU

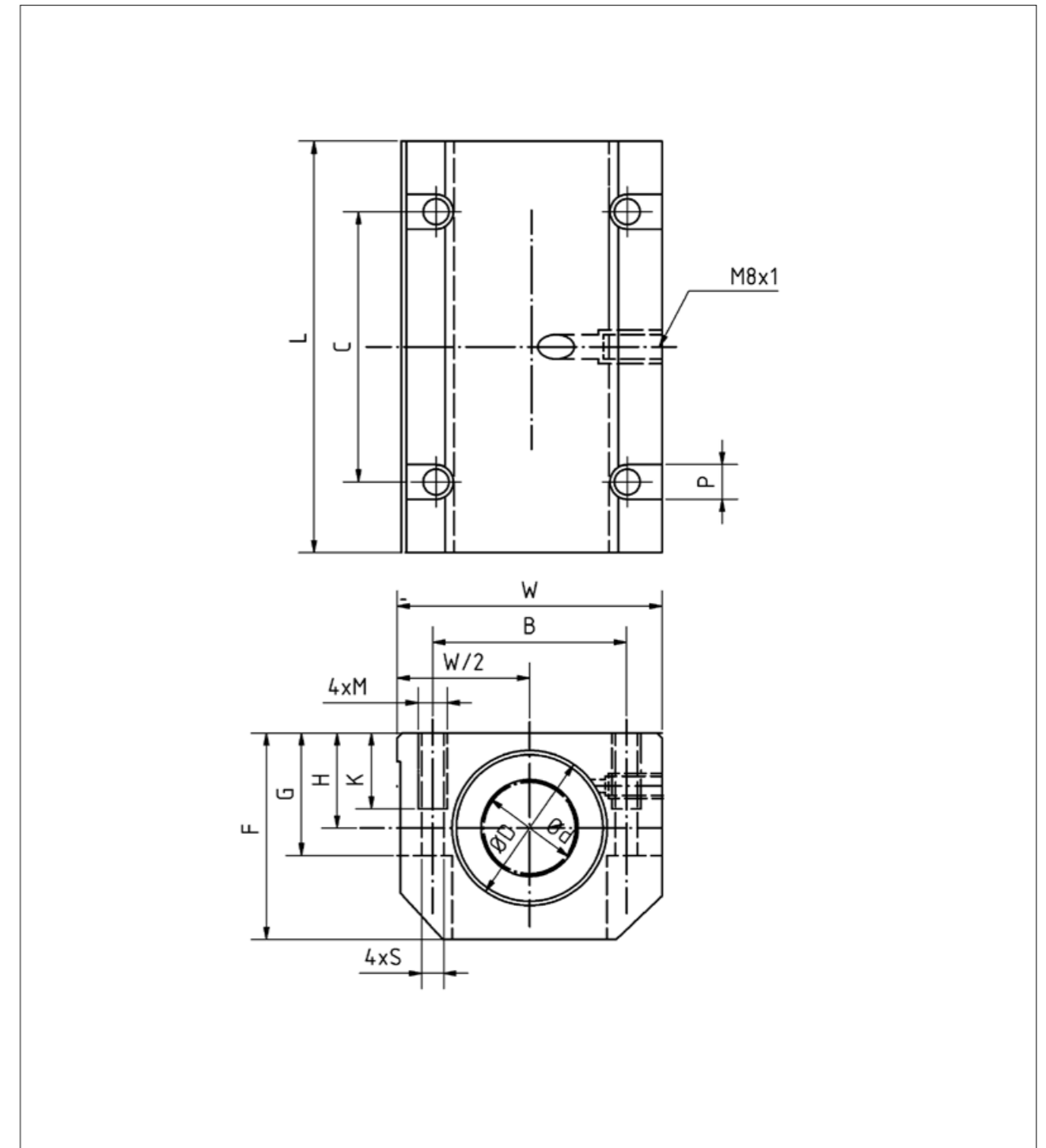

Tandem linear units with standard ball bushings

Closed casing and adjustable clearance

The linear units of the LSE...L-AJ series are twice as long as those of the LSE...AJ series. They are utilized where guidance with pretension or without play is required.

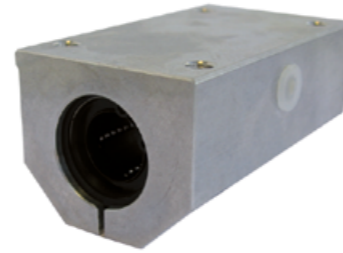

A LSE...L-AJ linear unit consists of the following:

- Casing (AlMgSi0,5)
- Two standard BBE...-AJ ball bushings
- Wiper seals made from NBR

Order reference	Dimensions [mm]										
	∅d	∅D H6	H	+0,01 -0,02	W	L +0,3	F	G	Y	B	C
LSE12LUU-AJ	12	22	18		43	76	35	25	10	32	56
LSE16LUU-AJ	16	26	22		53	84	42	30	12	40	64
LSE20LUU-AJ	20	32	25		60	104	50	34	13	45	76
LSE25LUU-AJ	25	40	30		78	130	60	40	15	60	94
LSE30LUU-AJ	30	47	35		87	152	70	48	16	68	106
LSE40LUU-AJ	40	62	45		108	176	90	60	20	86	124

Dimensions [mm]				Dynamic load rating [N]	Static load rating [N]	Weight [g]	Order reference
M	P	K	S				
M5	8	11	4,2	683	1 570	360	LSE12LUU-AJ
M6	10	13	5,2	710	1 780	530	LSE16LUU-AJ
M8	11	18	6,8	1 440	2 740	920	LSE20LUU-AJ
M10	15	22	8,6	1 490	3 140	1 820	LSE25LUU-AJ
M10	15	22	8,6	2 600	5 490	2 730	LSE30LUU-AJ
M12	18	26	10,3	3 872	8 040	5 210	LSE40LUU-AJ

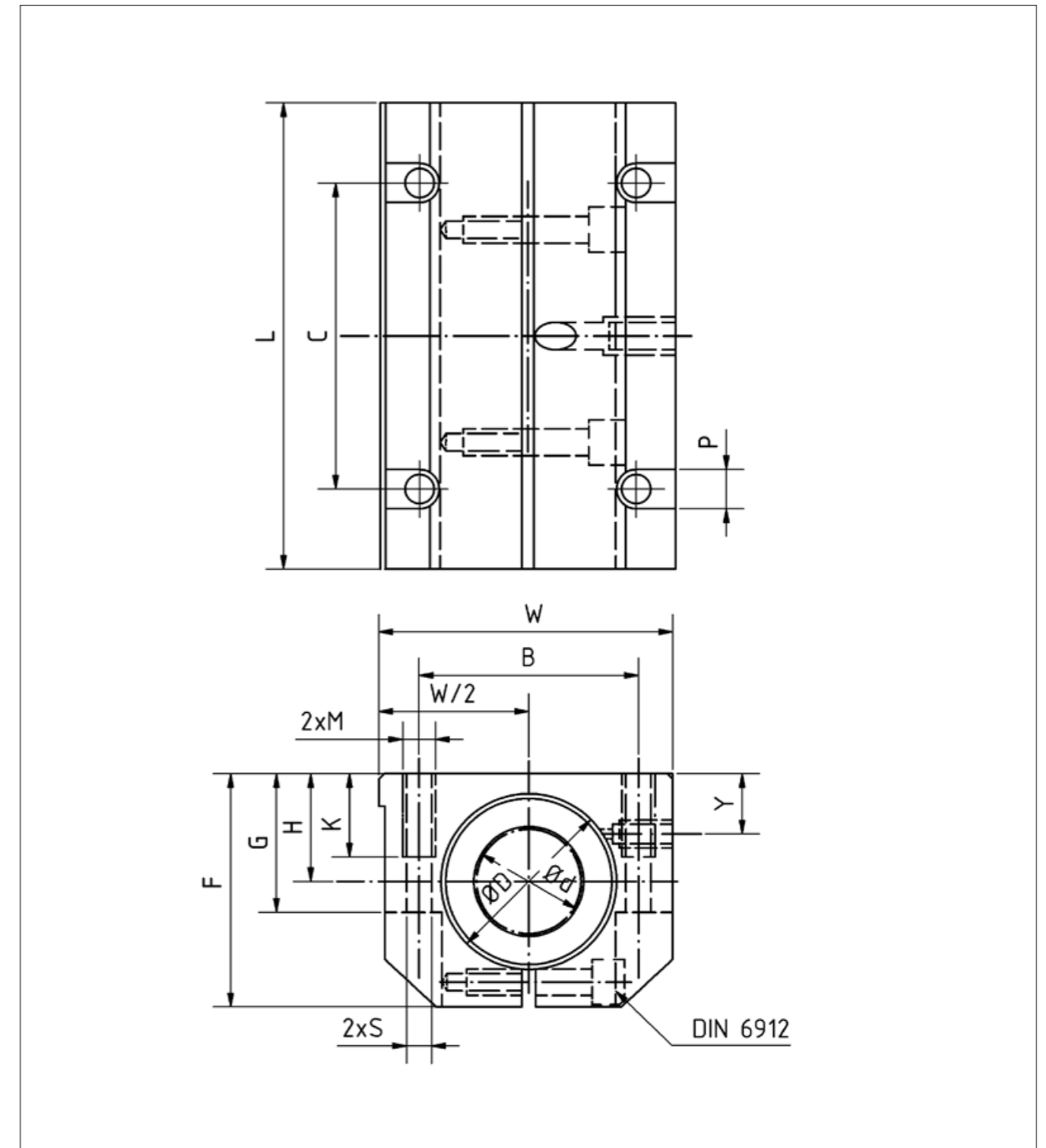

Tandem linear units with standard ball bushings

Open casing

The tandem linear units of the LSE...L-OP series are twice as long as those of the LSE...-OP series. They can be used where high moment loads exist, on long fully supported shafts.



A LSE...L-OP linear unit consists of the following:

- Casing (AlMgSi0,5)
- Two BBE...-OP standard ball bushings
- Wiper seals made from NBR

Order reference	Dimensions [mm]										
	Ød	ØD H6	H +0,01 -0,02	W	L +0,3	F	G	Y	X	T	
LSE12LUU-OP	12	22	18	43	76	30	25	8	19,5	16,65	
LSE16LUU-OP	16	26	22	53	84	35	30	12	21,5	22	
LSE20LUU-OP	20	32	25	60	104	42	34	13	27	25	
LSE25LUU-OP	25	40	30	78	130	51	40	15	33,5	31,5	
LSE30LUU-OP	30	47	35	87	152	60	48	16	39,5	33	
LSE40LUU-OP	40	62	45	108	176	77	60	20	45,5	43,5	

Dimensions [mm]							Dynamic load rating [N]	Static load rating [N]	Weight [g]	Order reference
B	C	M	P	K	S	R +0,6				
32	56	M5	8	11	4,2	7	683	1 570	290	LSE12LUU-OP
40	64	M6	10	13	5,2	9,4	710	1 780	440	LSE16LUU-OP
45	76	M8	11	18	6,8	10,2	1 440	2 740	790	LSE20LUU-OP
60	94	M10	15	22	8,6	12,9	1 490	3 140	1 560	LSE25LUU-OP
68	106	M10	15	22	8,6	14,4	2 600	5 490	2 300	LSE30LUU-OP
86	124	M12	18	34	10,3	18,2	3 872	8 040	4 500	LSE40LUU-OP

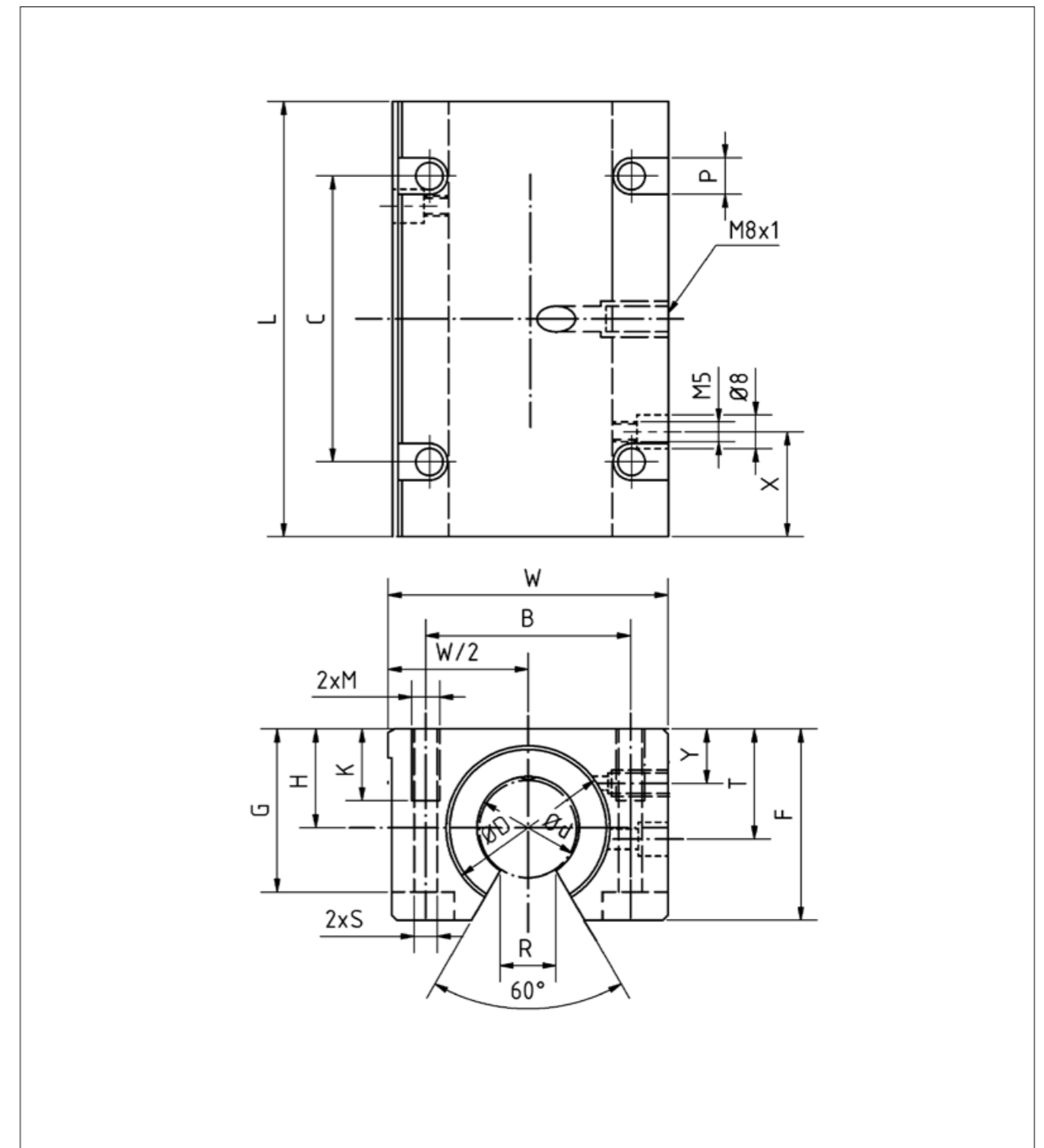

Tandem linear units with standard ball bushings

Open casing and adjustable clearance

The linear units of the LSE...L-AO series are twice as long as those of the LSE...AO series. They are utilized in guidance systems with pre-tension or without play where moment loads exist.



A LSE...L-AO linear unit consists of the following:

- Casing (AlMgSi0,5)
- Two BBE...-OP standard ball bushings
- Wiper seals made from NBR

Order reference	Dimensions [mm]										
	∅d	∅D H6	H +0,01 -0,02	W	L +0,3	F	G	Y	X	T	
LSE12LUU-AO	12	22	18	43	76	30	25	8	19,5	16,65	
LSE16LUU-AO	16	26	22	53	84	35	30	12	21,5	22	
LSE20LUU-AO	20	32	25	60	104	42	34	13	27	25	
LSE25LUU-AO	25	40	30	78	130	51	40	15	33,5	31,5	
LSE30LUU-AO	30	47	35	87	152	60	48	16	39,5	33	
LSE40LUU-AO	40	62	45	108	176	77	60	20	45,5	43,5	

Dimensions [mm]							Dynamic load rating [N]	Static load rating [N]	Weight [g]	Order reference
B	C	M	P	K	S	R +0,6				
32	56	M5	8	11	4,2	7	683	1 570	290	LSE12LUU-AO
40	64	M6	10	13	5,2	9,4	710	1 780	440	LSE16LUU-AO
45	76	M8	11	18	6,8	10,2	1 440	2 740	790	LSE20LUU-AO
60	94	M10	15	22	8,6	12,5	1 490	3 140	1 560	LSE25LUU-AO
68	106	M10	15	22	8,6	13,9	2 600	5 490	2 300	LSE30LUU-AO
86	124	M12	18	26	10,3	18	3 872	8 040	4 500	LSE40LUU-AO

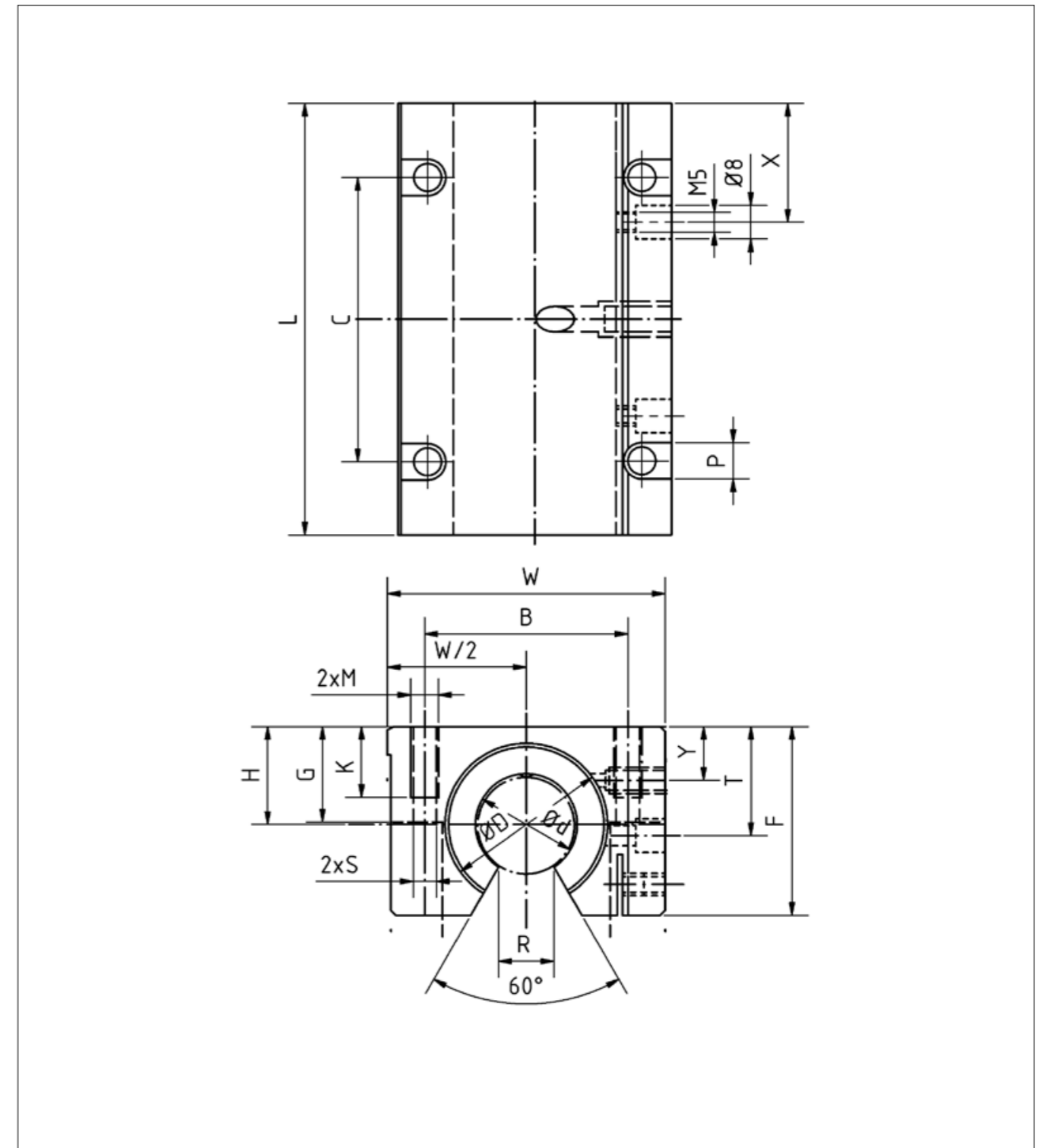

Quadro linear units with standard ball bushings

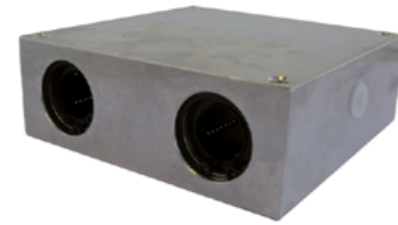

Closed casing

Quadro linear units of the LSE...Q series enable compact and simple table constructions. Details of shaft blocks (slides, supports) can be found on pages 65.

A LSE...Q linear unit consists of the following:

- Casing (AlMgSi0,5)
- Four BBE standard ball bushings
- Wiper seals made from NBR

Order reference	Dimensions [mm]								
	ød	ØD H6	H +0,01 -0,02	W	L +0,3	F	Y	A ±0,02	
LSE12QUU	12	22	16	85	85	32	13	42	
LSE16QUU	16	26	18	100	100	36	15	54	
LSE20QUU	20	32	23	130	130	46	19	72	
LSE25QUU	25	40	28	160	160	56	24	88	
LSE30QUU	30	47	32	180	180	64	27	96	
LSE40QUU	40	62	40	230	230	80	35	122	

Dimensions [mm]					Dynamic load rating [N]	Static load rating [N]	Weight [g]	Order reference
B	C	M	K	S				
73	73	M6	13	5,3	1 300	2 000	700	LSE12QUU
88	88	M6	13	5,3	1 400	2 200	1 020	LSE16QUU
115	115	M8	18	6,8	3 200	4 900	2 150	LSE20QUU
140	140	M10	22	9	5 500	8 500	4 070	LSE25QUU
158	158	M12	26	10,5	6 200	9 500	5 870	LSE30QUU
202	202	M16	34	13,5	10 500	14 000	11 780	LSE40QUU

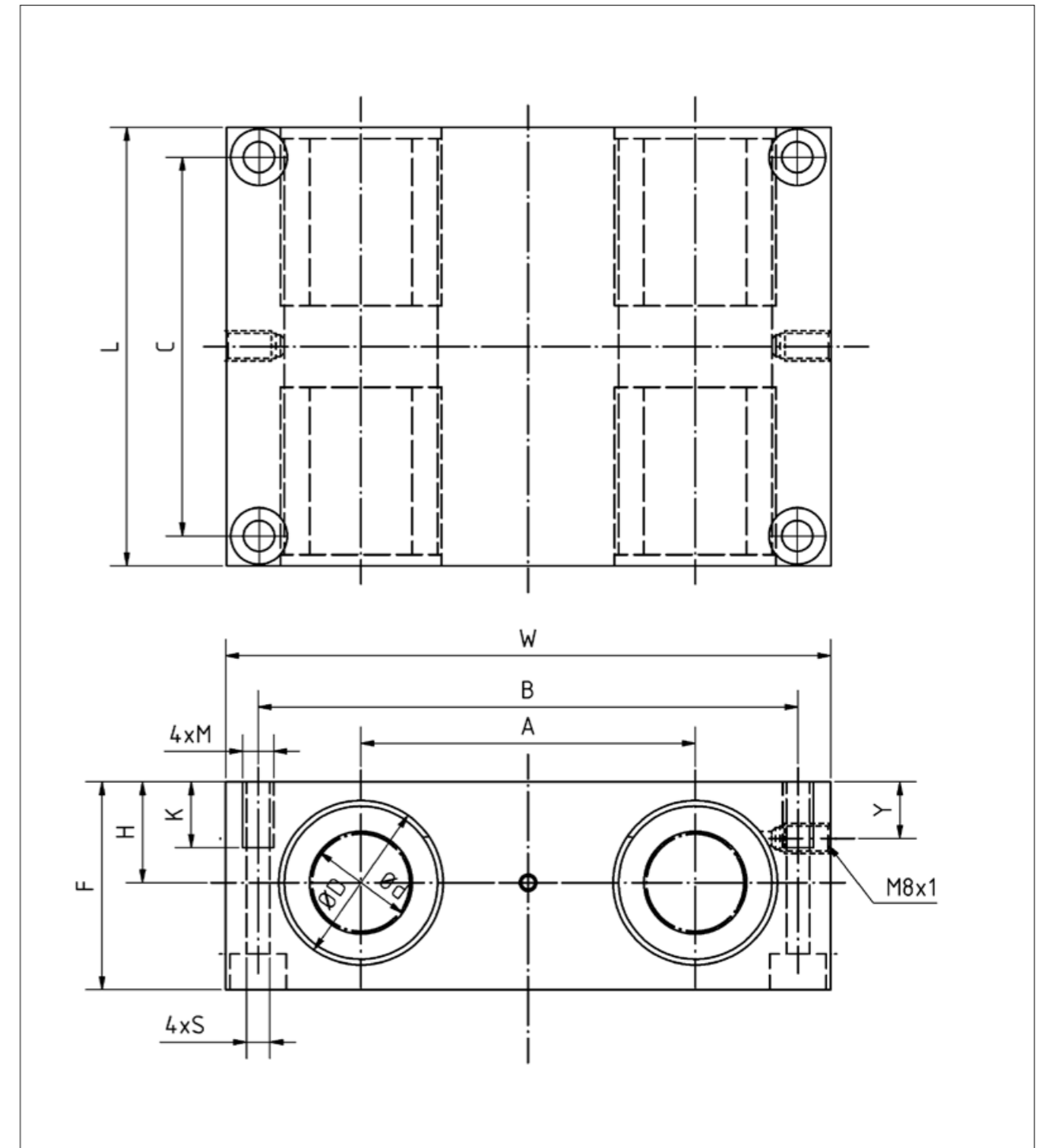

Quadro linear units with standard ball bushings

Open casing

Quadro linear units of the LSE...Q-OP series enable compact and simple linear conveying or table constructions.

A LSE...Q-OP linear unit consists of the following:

- Casing (AlMgSi0,5)
- Four BBE...-OP standard ball bushings
- Wiper seals made from NBR

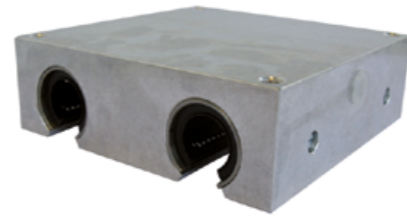

Order reference	Dimensions [mm]								
	Ød	ØD H6	H +0,01 -0,02	W	L +0,3	F	Y	A ±0,02	
LSE12QUU-OP	12	22	18	85	85	30	13	42	
LSE16QUU-OP	16	26	22	100	100	35	15	54	
LSE20QUU-OP	20	32	25	130	130	42	19	72	
LSE25QUU-OP	25	40	30	160	160	51	24	88	
LSE30QUU-OP	30	47	35	180	180	60	27	96	
LSE40QUU-OP	40	62	45	230	230	77	35	122	

Dimensions [mm]						Dynamic load rating [N]	Static load rating [N]	Weight [g]	Order reference
B	C	M	K	S	R				
73	73	M6	13	5,3	7	1 300	2 000	590	LSE12QUU-OP
88	88	M6	13	5,3	9,4	1 400	2 200	920	LSE16QUU-OP
115	115	M8	18	6,8	10,2	3 200	4 900	1 820	LSE20QUU-OP
140	140	M10	22	9	12,9	5 500	8 500	3 460	LSE25QUU-OP
158	158	M12	26	10,5	13,9	6 200	9 500	5 190	LSE30QUU-OP
202	202	M16	34	13,5	18,2	10 500	14 000	10 780	LSE40QUU-OP

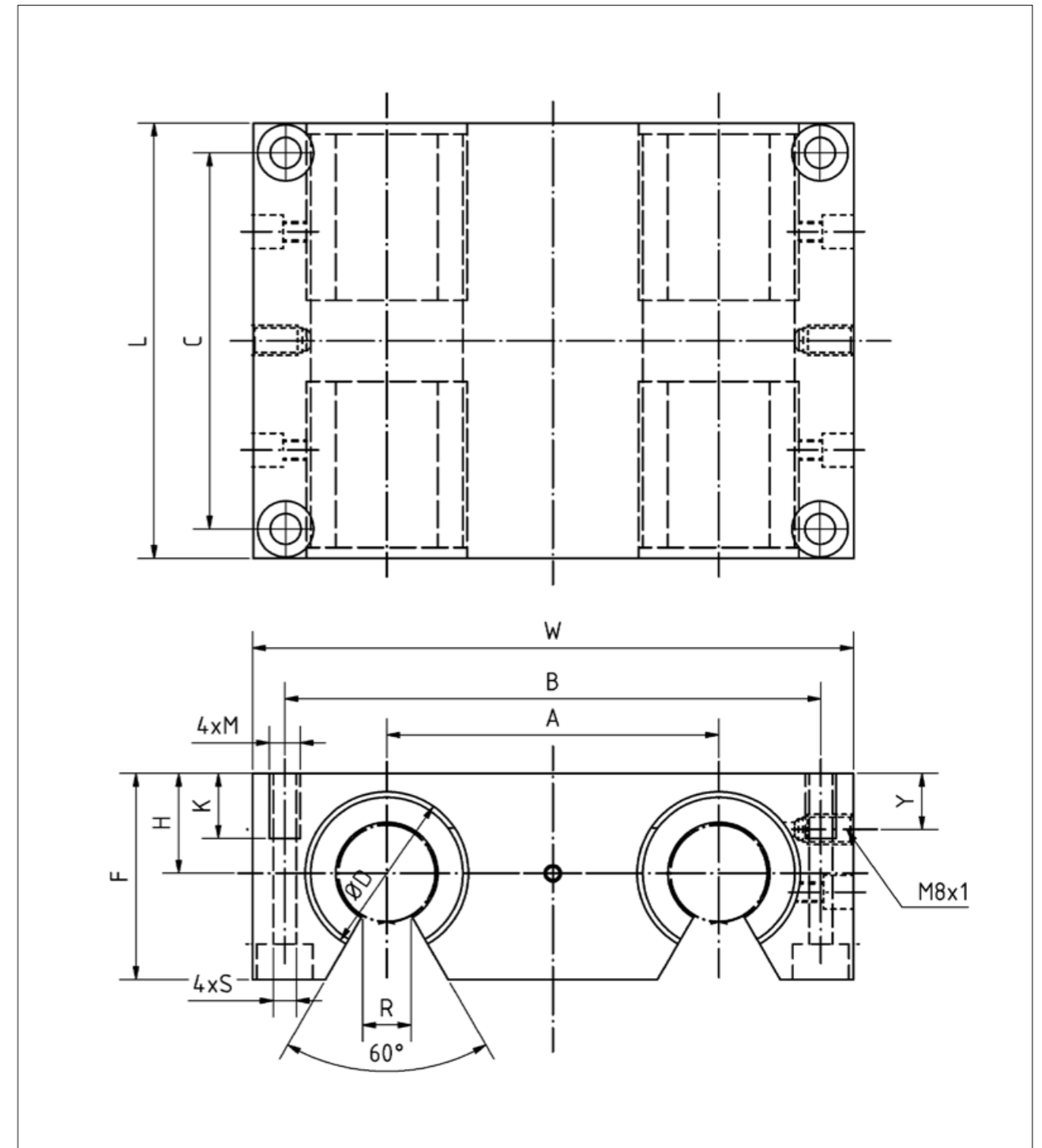

Linear units with super ball bushings, relubrication

Linear units with super ball bushings

Closed casing

Due to their design, the linear units of the LSET series with a relubrication system offer high precision in any type of installation.

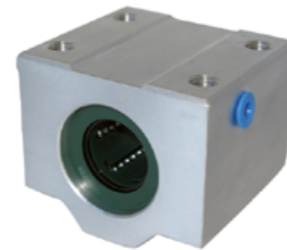

A LSET linear unit consists of the following:

- Casing (AlMgSi0,5)
- BBET super ball bushings
- Wiper seals made from NBR

The linear units offer substantial cost advantages to the user, because of reduced construction expenses.

The unit construction allows easier integration into installations. Reduced unit weight is obtained by using high grade aluminium, allowing for greater acceleration and higher speeds.

Order reference	Dimensions [mm]									
	Ød	H ±0,015	E ±0,015	W	L	F	G	T	X	Y
LSET8UU	8	15	17,5	35	32	28	22	5	-	-
LSET10UU	10	16	20	40	36	31,5	25	5	-	-
LSET12UU	12	18	21,5	43	39	35	28	5	-	-
LSET16UU	16	22	26,5	53	43	42	35	5	-	-
LSET20UU	20	25	30	60	54	50	42	5	19	9
LSET25UU	25	30	39	78	67	60	48	7	22,5	10
LSET30UU	30	35	43,5	87	79	70	58	8	26	11,5
LSET40UU	40	45	54	108	91	90	72	10	26,5	14

Dimensions [mm]					Dynamic load rating [N]	Static load rating [N]	Weight [g]	Order reference
B	C	M	K	S				
25	20	M4	9	3,3	423	534	59	LSET8UU
29	20	M5	11	4,3	750	935	90	LSET10UU
32	23	M5	11	4,3	1 020	1 290	116	LSET12UU
40	26	M6	13	5,3	1 250	1 550	205	LSET16UU
45	32	M8	18	6,6	2 090	2 630	326	LSET20UU
60	40	M10	22	8,4	3 780	4 720	624	LSET25UU
68	45	M10	22	8,4	5 470	6 810	980	LSET30UU
86	58	M12	26	10,5	6 590	8 230	1670	LSET40UU

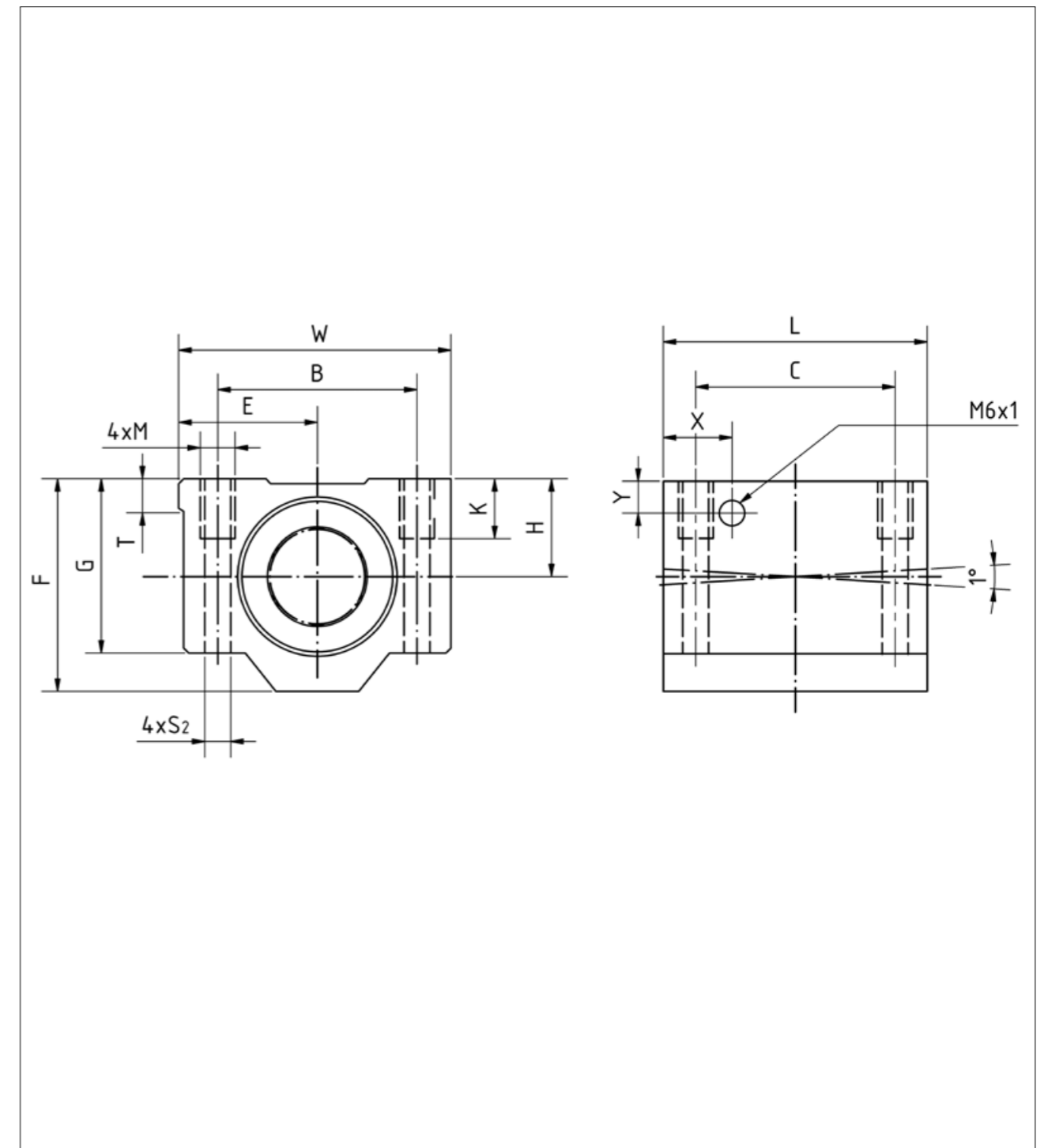

Linear units with super ball bushings

Open casing

The linear units of the LSET...-OP series with the re-lubricating option are used on long shafts which are fully supported. They offer a high level of rigidity and handle loads in all directions. The unit design allows for simpler integration into the installations.



A LSET...-OP linear unit consists of the following:

- Casing (AlMgSi0,5)
- A BBET...-OP super ball bushings
- Wiper seals made from NBR

Order reference	Dimensions [mm]										
	Ød	H ±0,015	E ±0,015	W	L	G	T	R	θ°	X	Y
LSET12UU-OP	12	18	21,5	43	39	28	5	6,5	66	14,5	7,5
LSET16UU-OP	16	22	26,5	53	43	35	5	9	68	15,5	9,5
LSET20UU-OP	20	25	30	60	54	42	5	9	55	19	9
LSET25UU-OP	25	30	39	78	67	51	7	11,5	57	22,5	10
LSET30UU-OP	30	35	43,5	87	79	60	8	14	57	26	11,5
LSET40UU-OP	40	45	54	108	91	77	10	19,5	56	26,5	14

Dimensions [mm]							Dynamic load rating [N]	Static load rating [N]	Weight [g]	Order reference
B	C	M	K	S	P	J				
32	23	M5	11	4,3	8	4,5	1 020	1 290	99	LSET12UU-OP
40	26	M6	13	5,3	9,5	5,5	1 250	1 550	175	LSET16UU-OP
45	32	M8	18	6,6	11	6,5	2 090	2 630	275	LSET20UU-OP
60	40	M10	22	8,4	14	8,6	3 780	4 720	558	LSET25UU-OP
68	45	M10	22	8,4	14	8,6	5 470	6 810	860	LSET30UU-OP
86	58	M12	26	10,5	17,5	10,8	6 590	8 230	1 490	LSET40UU-OP

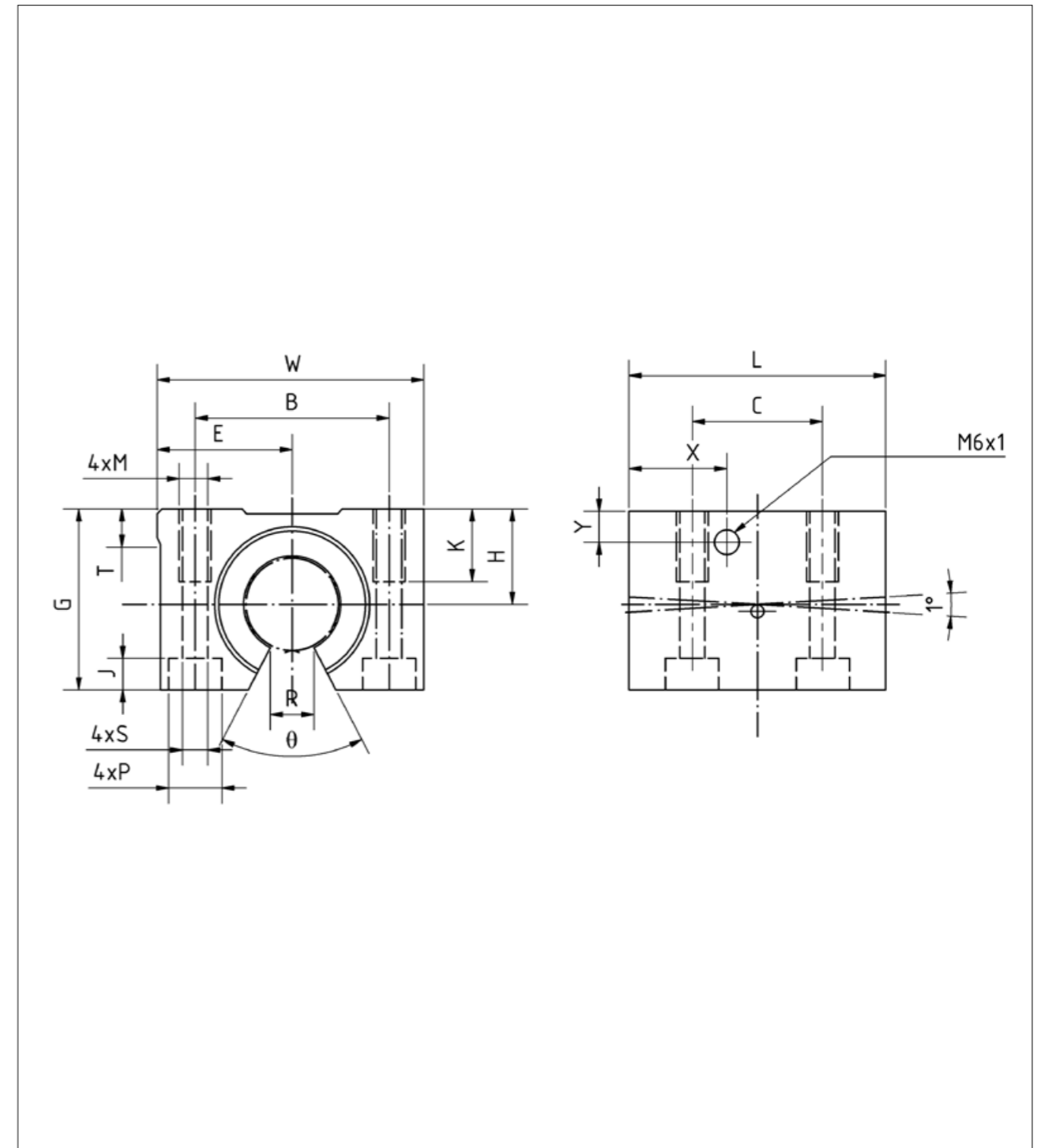

Linear units with super ball bushings

Open casing and adjustable clearance

The linear units of the LSET...-AO series are used where guidance with pretension or with play is required, Radial clearance can be set by means of an adjusting screw.

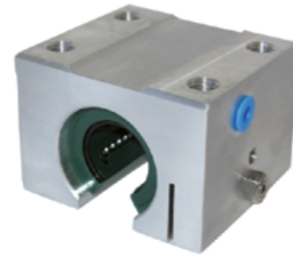

A LSET...-AO linear unit consists of the following:

- Casing (AlMgSi0,5)
- A BBET...-OP super ball bushings
- Wiper seals made from NBR

Order reference	Dimensions [mm]												
	Ød	H ±0,015	E ±0,015	W	L	F	G	Z	T	R	θ°	X	Y
LSET12UU-AO	12	18	21,5	43	39	28	3,2	5	5	6,5	66	14,5	7,5
LSET16UU-AO	16	22	26,5	53	43	35	3,2	6	5	9	68	15,5	9,5
LSET20UU-AO	20	25	30	60	54	42	4,5	8	5	9	55	19	9
LSET25UU-AO	25	30	39	78	67	51	5,5	10	7	11,5	57	22,5	10
LSET30UU-AO	30	35	43,5	87	79	60	5,5	12	8	14	57	26	11,5
LSET40UU-AO	40	45	54	108	91	77	5	15	10	19,5	56	26,5	14

Dimensions [mm]							Dynamic load rating [N]	Static load rating [N]	Weight [g]	Order reference
B	C	M	K	S	P	J				
32	23	M5	11	4,3	8	11,5	1 020	1 290	99	LSET12UU-AO
40	26	M6	13	5,3	9,5	14	1 250	1 550	175	LSET16UU-AO
45	32	M8	18	6,6	11	18	2 090	2 630	275	LSET20UU-AO
60	40	M10	22	8,4	14	22	3 780	4 720	558	LSET25UU-AO
68	45	M10	22	8,4	14	26	5 470	6 810	860	LSET30UU-AO
86	58	M12	26	10,5	17,5	33	6 590	8 230	1 490	LSET40UU-AO

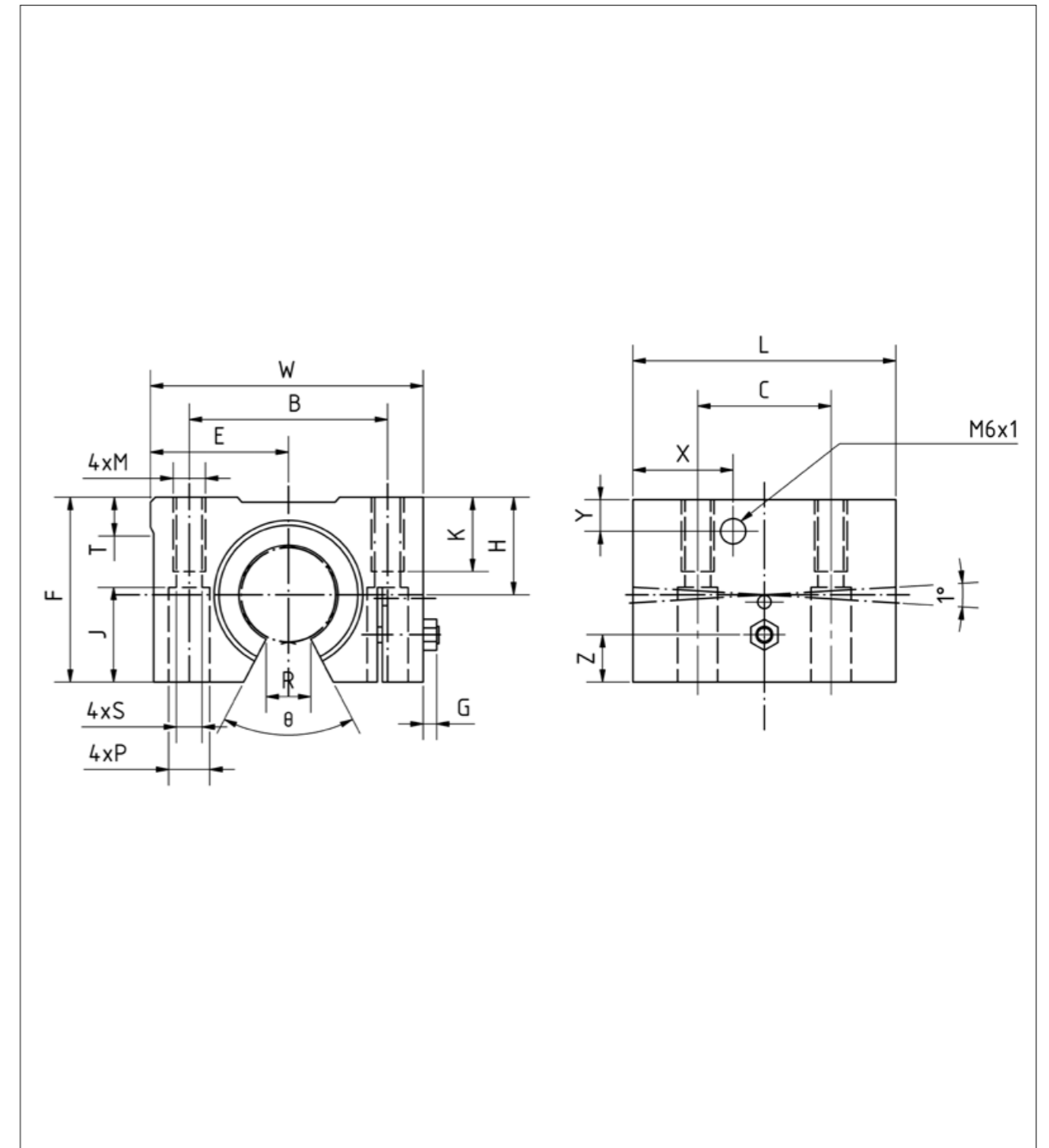

Tandem linear units with super ball bushings

Closed casing

The tandem linear units of the LSET...L series are twice as long as those of the LSET series. They can be used where high moment loads exist.

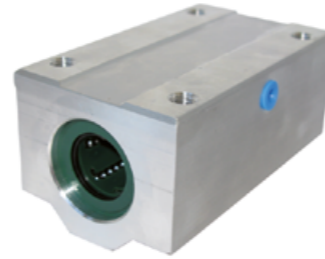

A LSET...L-OP linear unit consists of the following:

- Casing (AlMgSi0,5)
- Two BBET...-OP super ball bushings
- Wiper seals made from NBR

Order reference	Dimensions [mm]								
	Ød	H ±0,015	E ±0,015	W	L	F	G	T	Y
LSET8LUU	8	15	17,5	35	62	28	22	5	6,5
LSET10LUU	10	16	20	40	70	31,5	25	5	7
LSET12LUU	12	18	21,5	43	76	35	28	5	7,5
LSET16LUU	16	22	26,5	53	84	42	35	5	9,5
LSET20LUU	20	25	30	60	104	50	42	5	9
LSET25LUU	25	30	39	78	130	60	48	7	10
LSET30LUU	30	35	43,5	87	152	70	58	8	11,5
LSET40LUU	40	45	54	108	176	90	72	10	14

Dimensions [mm]					Dynamic load rating [N]	Static load rating [N]	Weight [g]	Order reference
B	C	M	K	S				
25	50	M4	9	3,3	685	1 068	119	LSET8LUU
29	52	M5	11	4,3	1 215	1 870	175	LSET10LUU
32	56	M5	11	4,3	1 652	2 580	227	LSET12LUU
40	64	M6	13	5,3	2 025	3 100	390	LSET16LUU
45	76	M8	18	6,6	3 390	5 260	630	LSET20LUU
60	94	M10	22	8,4	6 120	9 440	1 210	LSET25LUU
68	106	M10	22	8,4	8 860	13 620	1 880	LSET30LUU
86	124	M12	26	10,5	10 680	16 460	3 280	LSET40LUU

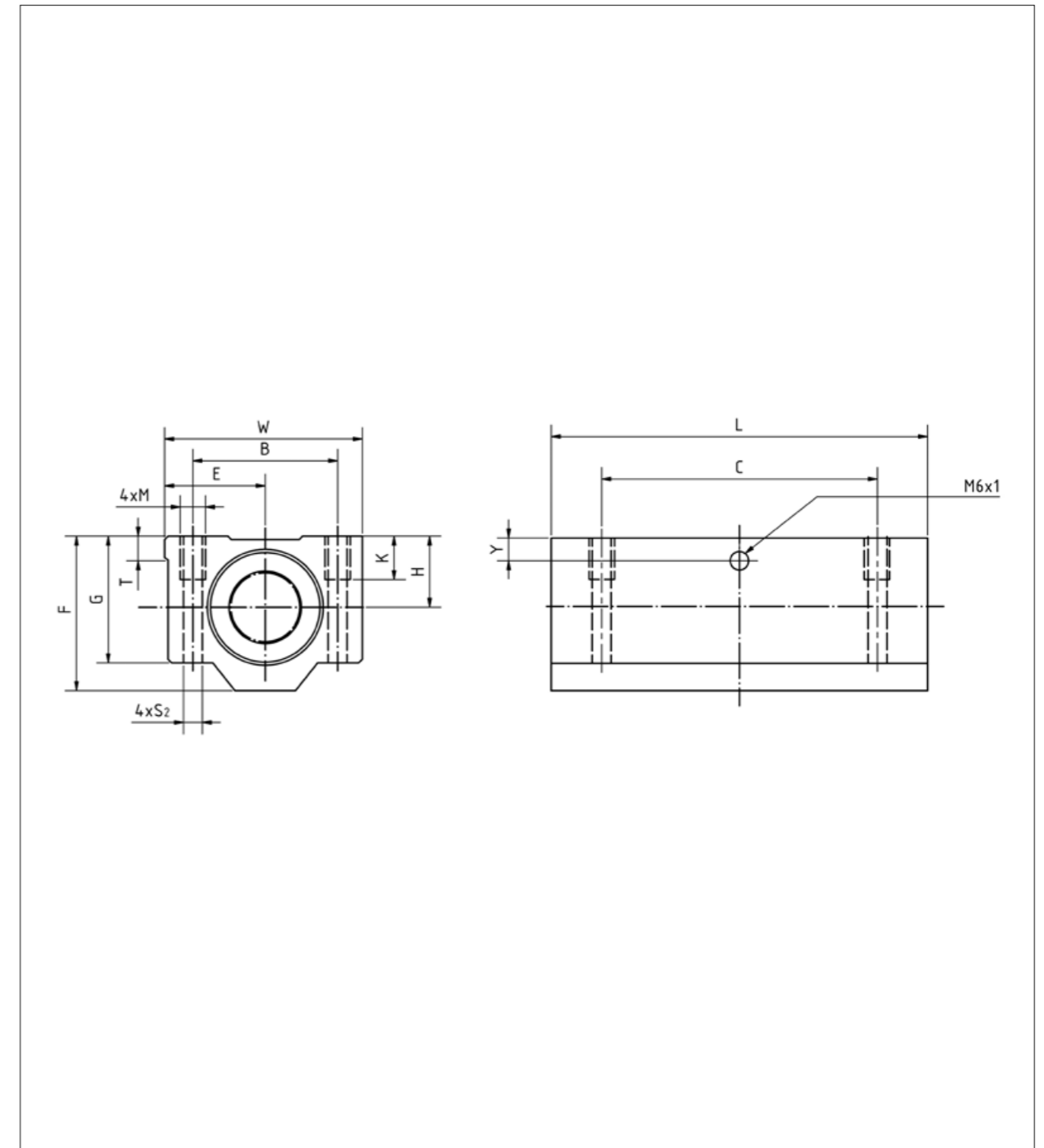

Tandem linear units with super ball bushings

Open casing

The tandem linear units of the LSET...L-OP series are twice as long as those of the LSET...-OP series. They can be used where high moment loads exist on long shaft which are fully supported.

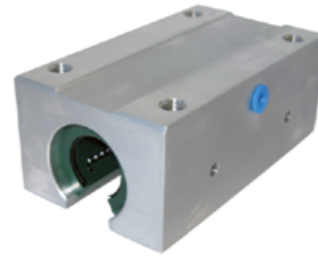

A LSET...L-OP linear unit consists of the following:

- Casing (AlMgSi0,5)
- Two BBET...-OP super ball bushings
- Wiper seals made from NBR

Order reference	Dimensions [mm]									
	Ød	H ±0,015	E ±0,015	W	L	G	T	R	θ°	Y
LSET12LUU-OP	12	18	21,5	43	76	28	5	6,5	66	7,5
LSET16LUU-OP	16	22	26,5	53	84	35	5	9	68	9,5
LSET20LUU-OP	20	25	30	60	104	42	5	9	55	9
LSET25LUU-OP	25	30	39	78	130	51	7	11,5	57	10
LSET30LUU-OP	30	35	43,5	87	152	60	8	14	57	11,5
LSET40LUU-OP	40	45	54	108	176	77	10	19,5	56	14

Dimensions [mm]							Dynamic load rating [N]	Static load rating [N]	Weight [g]	Order reference
B	C	M	K	S	P	J				
32	56	M5	11	4,3	8	4,5	1 652	2 580	190	LSET12LUU-OP
40	64	M6	13	5,3	9,5	5,5	2 025	3 100	312	LSET16LUU-OP
45	76	M8	18	6,6	11	6,5	3 390	5 260	505	LSET20LUU-OP
60	94	M10	22	8,4	14	8,6	6 120	9 440	1 050	LSET25LUU-OP
68	106	M10	22	8,4	14	8,6	8 860	13 620	1 630	LSET30LUU-OP
86	124	M12	26	10,5	17,5	10,8	10 680	16 460	2 880	LSET40LUU-OP

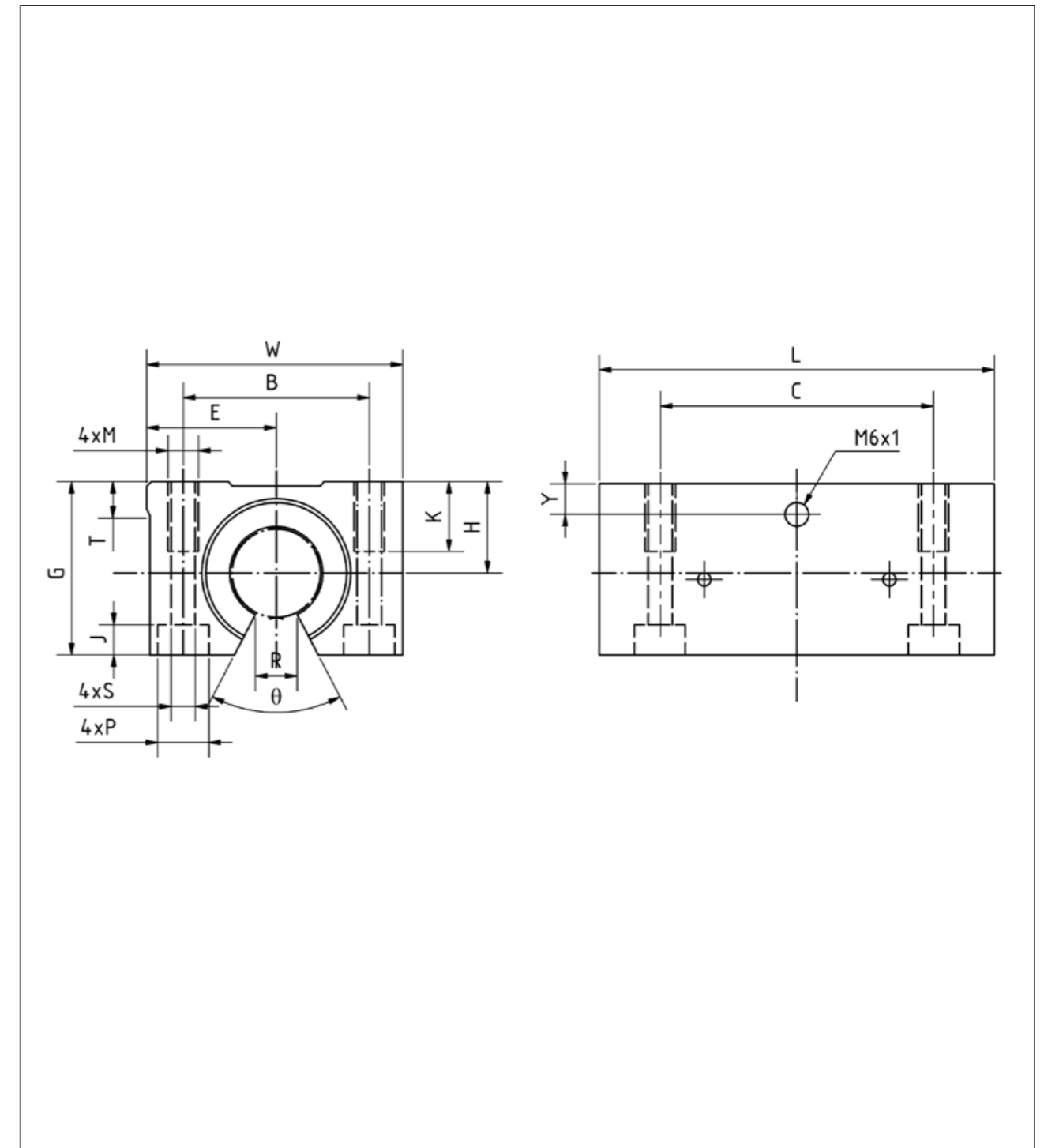

Tandem linear units with super ball bushings

Open casing and adjustable clearance

The linear units of the LSET...L-AO series are twice as long as those of the LSET...AO series. They are utilized in guidance systems with pretension or without play where moment loads exist.

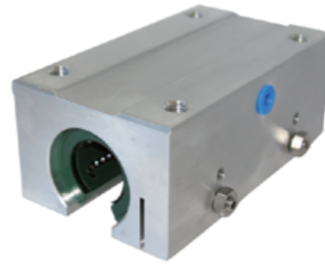

LSET...L-AO linear unit consists of the following:

- Casing (AlMgSi0,5)
- Two BBET...-OP super ball bushings
- Wiper seals made from NBR

Order reference	Dimensions [mm]												
	ød	H ±0,015	E ±0,015	W	L	F	G	Z	A	N	T	R	θ°
LSET12LUU-AO	12	18	21,5	43	76	28	3,2	5	19,5	37	5	6,5	66
LSET16LUU-AO	16	22	26,5	53	84	35	3,2	6	21,5	41	5	9	68
LSET20LUU-AO	20	25	30	60	104	42	4,5	8	27	50	5	9	55
LSET25LUU-AO	25	30	39	78	130	51	5,5	10	33,5	63	7	11,5	57
LSET30LUU-AO	30	35	43,5	87	152	60	5,5	12	39,5	73	8	14	57
LSET40LUU-AO	40	45	54	108	176	77	5	15	45,5	85	10	19,5	56

Dimensions [mm]								Dynamic load rating [N]	Static load rating [N]	Weight [g]	Order reference
Y	B	C	M	K	S	P	J				
7,5	32	56	M5	11	4,3	8	11,5	1 652	2 580	190	LSET12LUU-AO
9,5	40	64	M6	13	5,3	9,5	14	2 025	3 100	312	LSET16LUU-AO
9	45	76	M8	18	6,6	11	18	3 390	5 260	505	LSET20LUU-AO
10	60	94	M10	22	8,4	14	22	6 120	9 440	1 050	LSET25LUU-AO
11,5	68	106	M10	22	8,4	14	26	8 860	13 620	1 630	LSET30LUU-AO
14	86	124	M12	26	10,5	17,5	33	10 680	16 460	2 880	LSET40LUU-AO

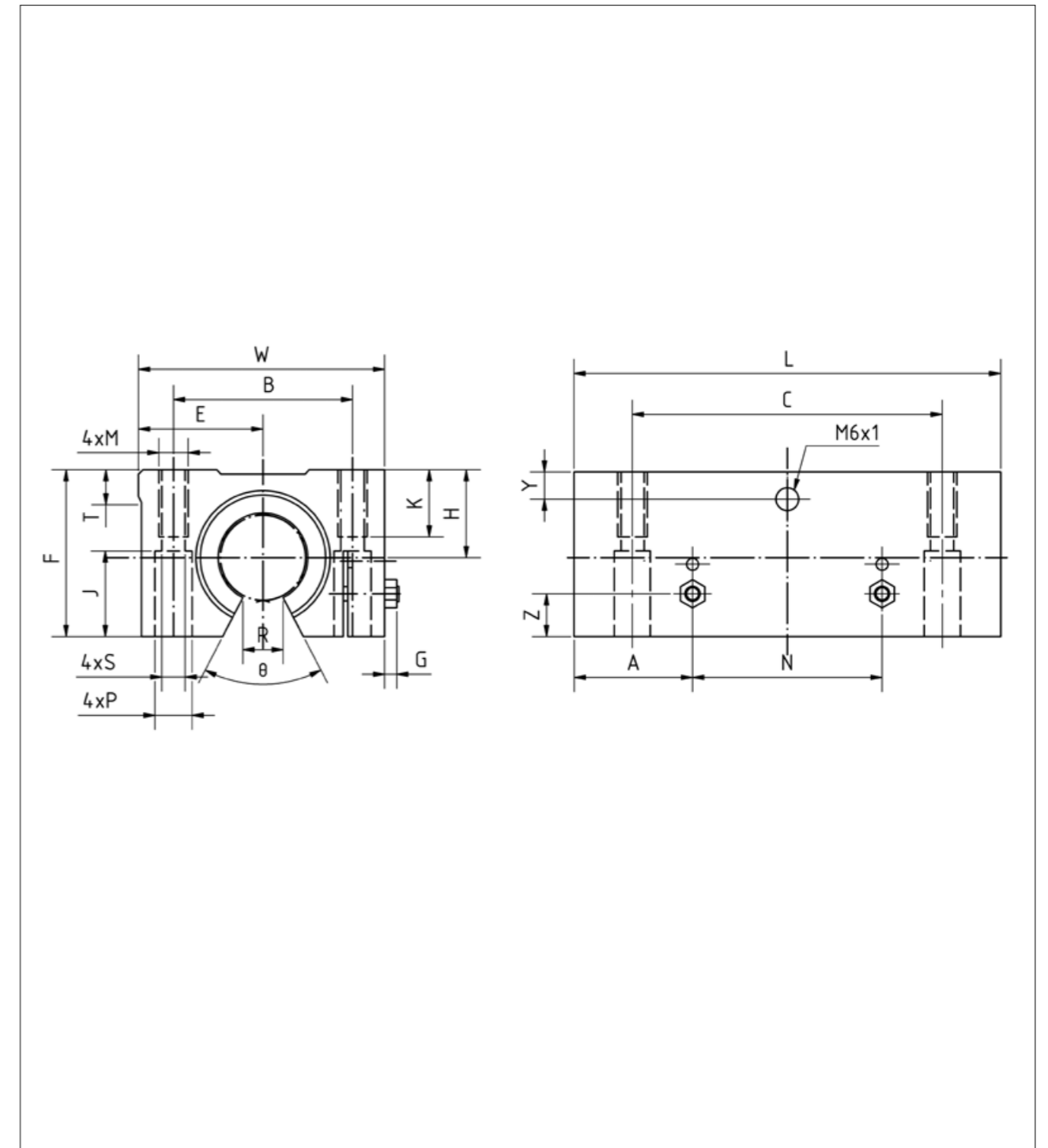

Support rail

Without flange (Series SR 10)

For supporting shafts in applications utilizing open ball bushings, shaft supports made of an aluminium alloy are available.

The shaft supports without 'SR' flange are suitable for constructions in which the shaft can be mounted from below.

For continuous support, the shaft supports can be installed one behind the other. It is possible to shorten them to the required length, if only partial support is required.

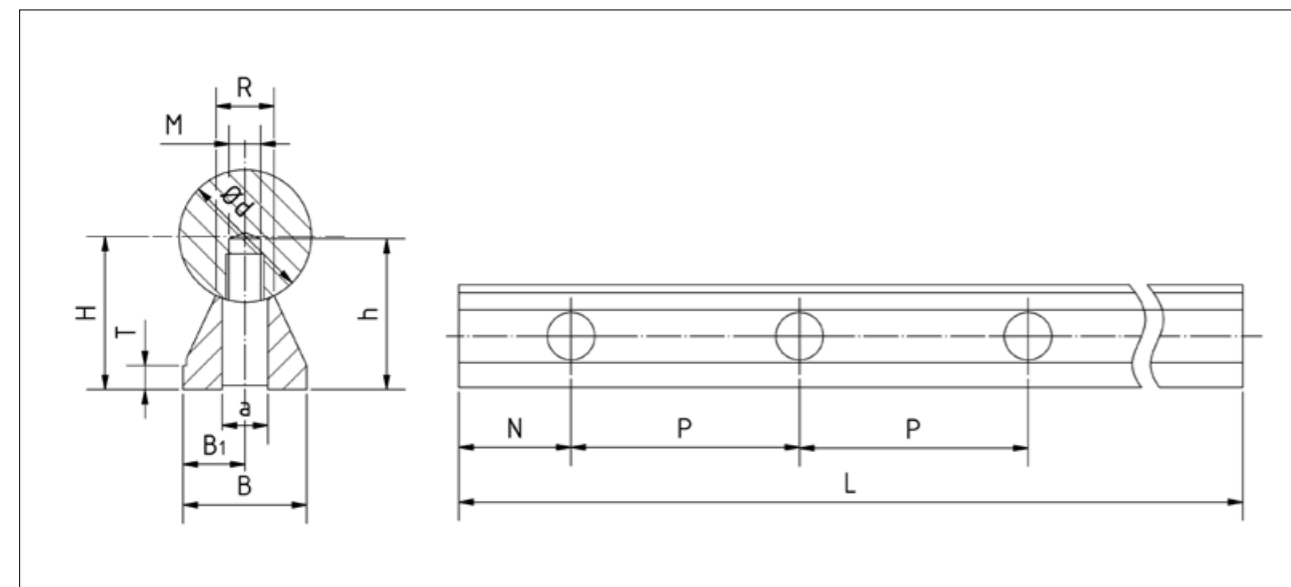

Order reference	Dimensions [mm]												Weight in case of max. length [g]
	Ød	H ±0,02	h	B ±0,02	B1 ±0,02	T	R	M	a	P	N	L max	
SR10-12	12	14,5	15,5	11	5,5	3	5,4	M4	4,5	75	37,5	2 400	440
SR10-16	16	18	16	14	7	3	7	M5	5,5	75	37,5	2 400	540
SR10-20	20	22	20	17	8,5	3	8,1	M6	6,6	75	37,5	2 400	810
SR10-25	25	26	25	21	10,5	3	10,3	M8	9	75	37,5	2 400	1 060
SR10-30	30	30	30	23	11,5	3	11	M10	11	100	50	2 400	1 250
SR10-40	40	39	38	30	15	4	15	M12	13,5	100	50	2 400	2 160
SR10-50	50	46	45	35	17,5	5	19	M14	15,5	100	50	2 400	2 941

Shafts must be ordered separately.
Order designation for support rail with mounted shaft, s. page 73.

With flange (Series SR 20)

For supported shaft applications involving open ball bushings, shaft supports made of an aluminium alloy are available.

For continuous support, the shaft supports can be installed one behind the other.

It is possible to shorten them to the required length, if only partial support is required.

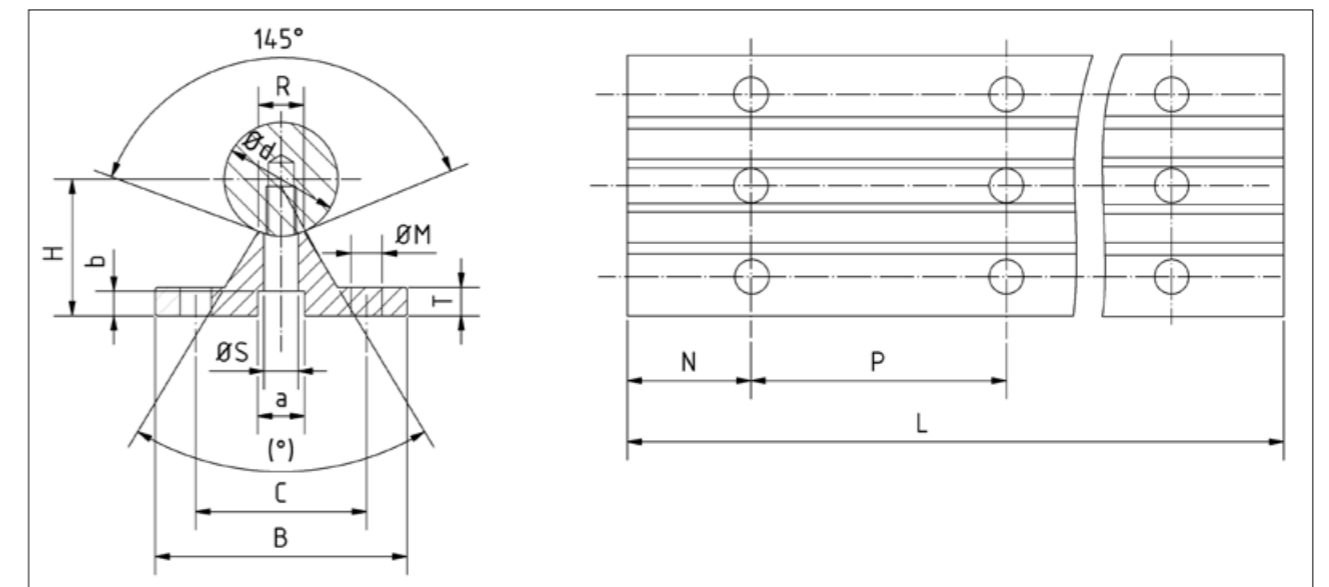

Order reference	Dimensions [mm]																	Weight in case of max. length [g]
	Ød	H ±0,02	B	C ±0,15	T	R -0,3	a	b	M	S	(°)	P1	P2	N1	N2	L max		
SR20-12	12	22	40	29	5	5,8	8	5	4,5	4,5	50	75	120	37,5	60	599,5	520	
SR20-16	16	26	45	33	5	7	9,5	6	5,5	5,5	50	100	150	50	75	599,5	640	
SR20-20	20	32	52	37	6	8,3	11	6,5	6,6	6,6	50	100	150	50	75	599,5	900	
SR20-25	25	36	57	42	6	10,8	14	8,5	6,6	9	50	120	200	60	100	599,5	1 080	
SR20-30	30	42	69	51	7	11	17	10,5	9	11	50	150	200	75	100	599,5	1 430	
SR20-40	40	50	73	55	8	15	17	10,5	9	11	50	200	300	100	150	599,5	1 810	
SR20-50	50	60	84	63	9	19	19	12,5	11	13	40	200	300	100	150	599,5	2 450	

P1/N1 applications where the load acts transverse to the ball bushings opening and loading is near the load capacity limit.
P2/N2 for general requirements.

Shafts must be ordered separately.
Order designation for support rail with mounted shaft, s. page 73.

For lateral fastening with one row of holes

Shaft support SR30 is suitable in constructions which utilize linear units with casings open to one side (LSE...-SOP and LSE...-SAO) or open ball bushings.

For continuous support, the shaft supports can be installed one behind the other. It is possible to shorten them to the required length, if only partial support is required.

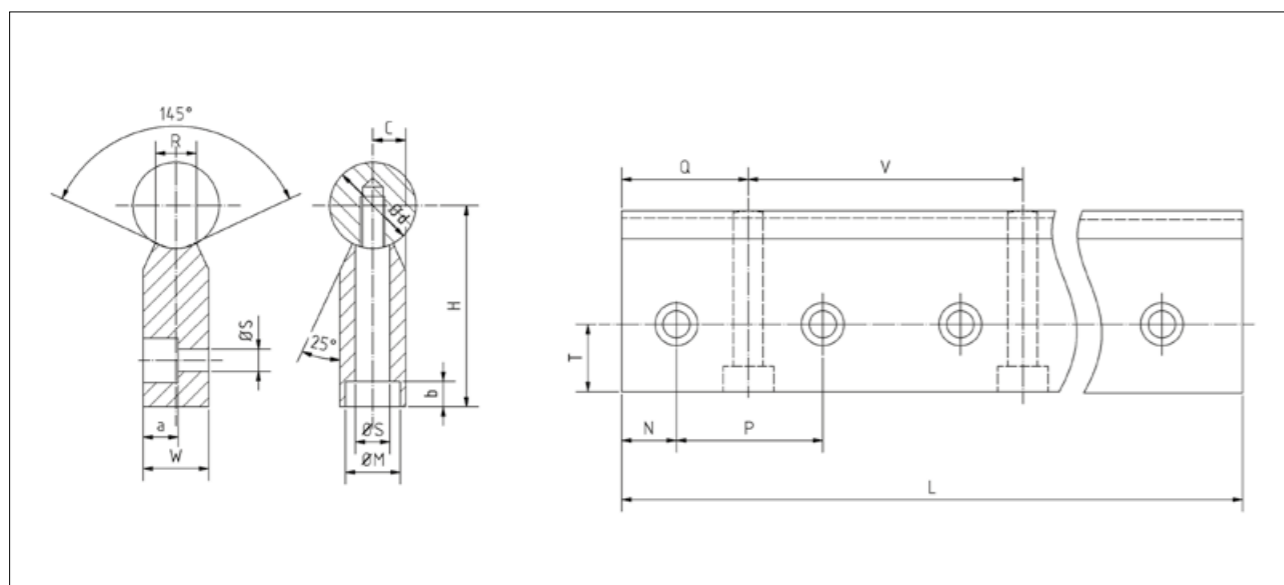
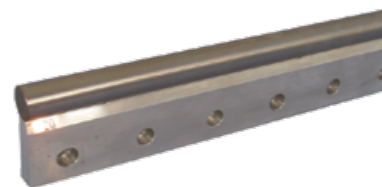

Order reference	Dimensions [mm]															Weight in case of max. length [g]
	Ød	H	W	T	C	R	ØS	ØM	b	a	P	N	Q	V	L max	
SR30-20	20	52	15	15	7,5	8,3	6,6	11	8,5	8,5	50	25	50	100	599,5	1 100
SR30-25	25	62	20	18	10	10,8	9	15	15	11	60	30	60	120	599,5	1 500
SR30-30	30	72	25	21	12,5	11	11	18	15,3	13,5	75	37,5	75	150	599,5	2 100
SR30-40	40	88	30	25	15	15	11	18	19	16	100	50	100	200	599,5	3 000
SR30-50	50	105	35	30	17,5	19	14	20	21,5	18,5	100	50	100	200	599,5	4 200

Shafts must be ordered separately.
Order designation for support rail with mounted shaft, s. page 73.

For lateral fastening with a double row of holes

Shaft support SR40 is suitable in constructions which utilize linear units with casings open to one side (LSE...-SOP and LSE...-SAO) or open ball bushings.

For continuous support, the shaft supports can be installed one behind the other. It is possible to shorten them to the required length, if only partial support is required.

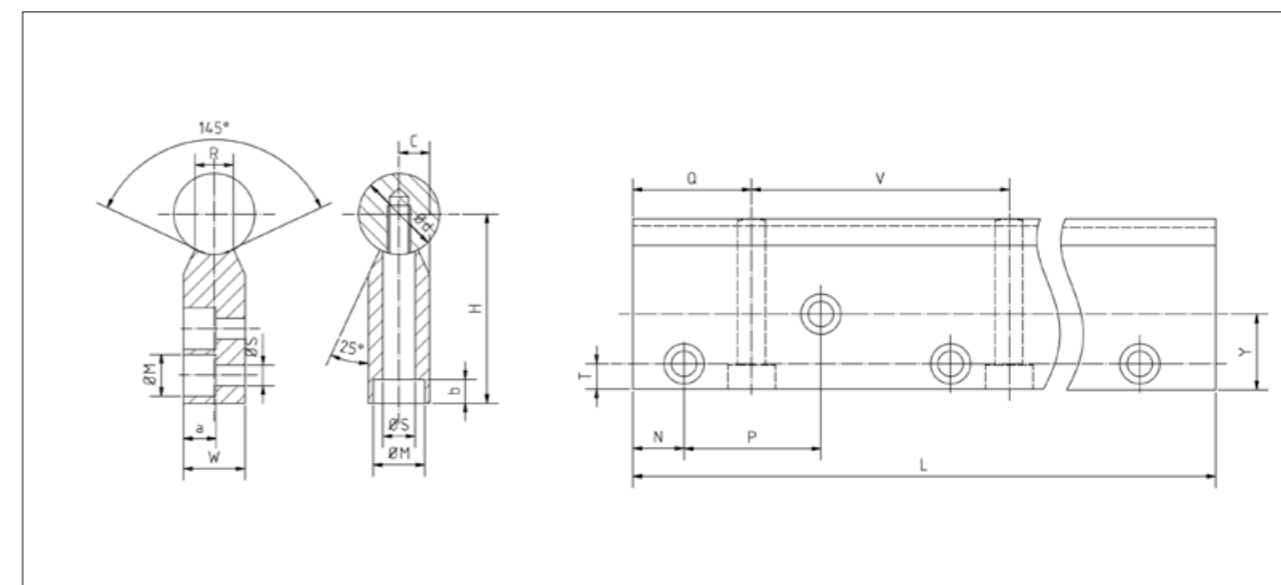

Order reference	Dimensions [mm]																	Weight in case of max. length [g]
	Ød	H	W	T	C	Y	R	ØS	ØM	b	a	P	N	Q	V	L max		
SR40-20	20	52	15	8	7,5	22	8,3	6,6	11	8,5	8,5	37,5	18,75	37,5	75	599,5	1 000	
SR40-25	25	62	20	10	10	26	10,8	9	15	15	11	37,5	18,75	37,5	75	599,5	1 300	
SR40-30	30	72	25	12	12,5	30	11	11	18	15,3	13,5	50	25	50	100	599,5	1 900	
SR40-40	40	88	30	12	15	38	15	14	20	19	16	50	25	50	100	599,5	2 700	
SR40-50	50	105	35	15	17,5	45	19	16	24	21,5	18,5	50	25	50	100	599,5	3 700	

Shafts must be ordered separately.
Order designation for support rail with mounted shaft, s. page 73.

Shaft supports

Our 'SK' shaft blocks offer a cost-effective solution for clamping shafts. The shaft blocks are made from aluminium and are characterized by their high rigidity and precision.

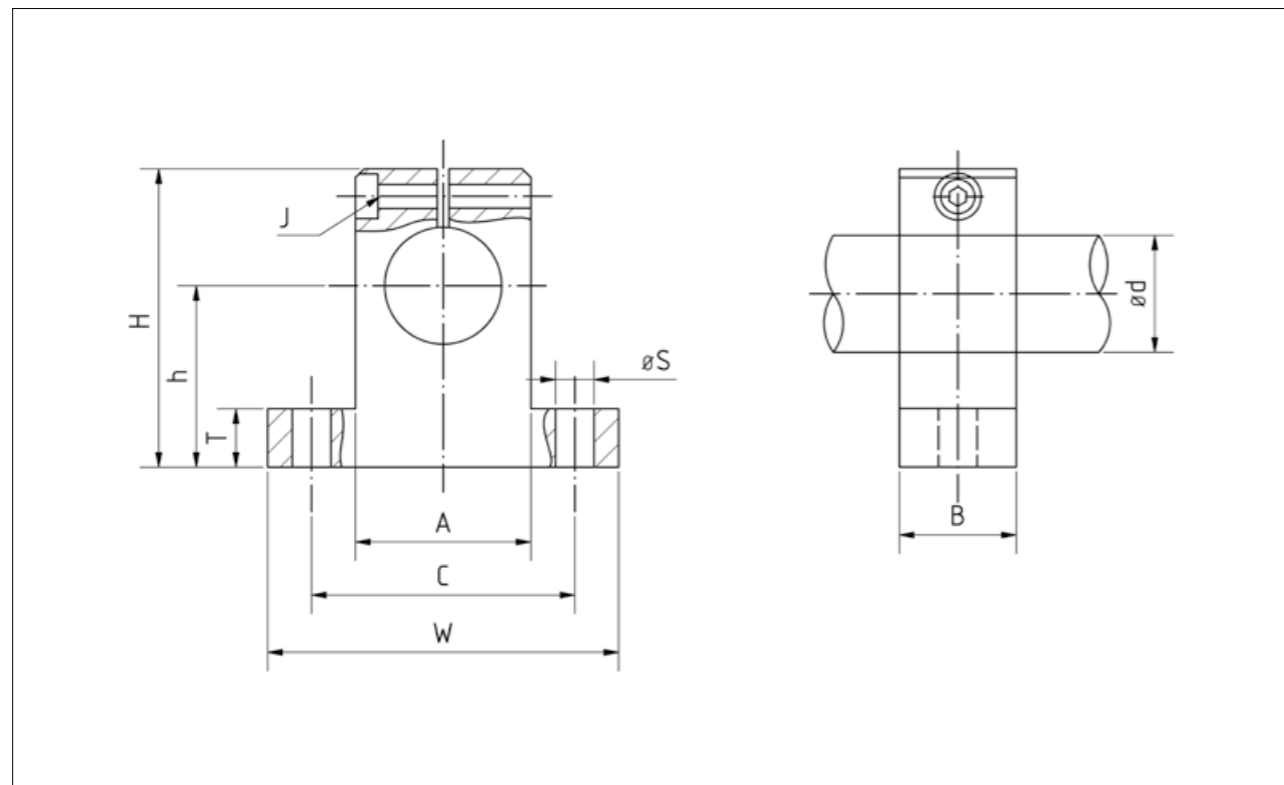

Order reference	Dimensions [mm]										Weight [g]
	Ød H8	H	h ±0,02	W	A	B	C ±0,15	T	S	J	
SK8	8	27	15	32	16	10	25	5	4,5	3	10
SK12	12	35	20	42	20	12	32	5,5	5,5	3	20
SK16	16	42	25	50	26	16	40	6,5	5,5	3	30
SK20	20	50	30	60	32	20	45	8	5,5	4	70
SK25	25	58	35	74	38	25	60	9	6,6	5	140
SK30	30	68	40	84	45	28	68	10	9	6	200
SK40	40	86	50	108	56	32	86	12	11	8	480
SK50	50	100	60	130	80	40	108	14	11	8	1 900
SK60	60	124	75	160	100	48	132	15	13,5	8	3 600

Traverse

For the quadro-linear units of the LSEQ and LSEQ...-OP series, tandem-shaft blocks are available in two models.

Model A is utilized where the shaft blocks are fixed and the linear blocks moving.

Model B enables moving of the shaft, with the linear unit fixed.

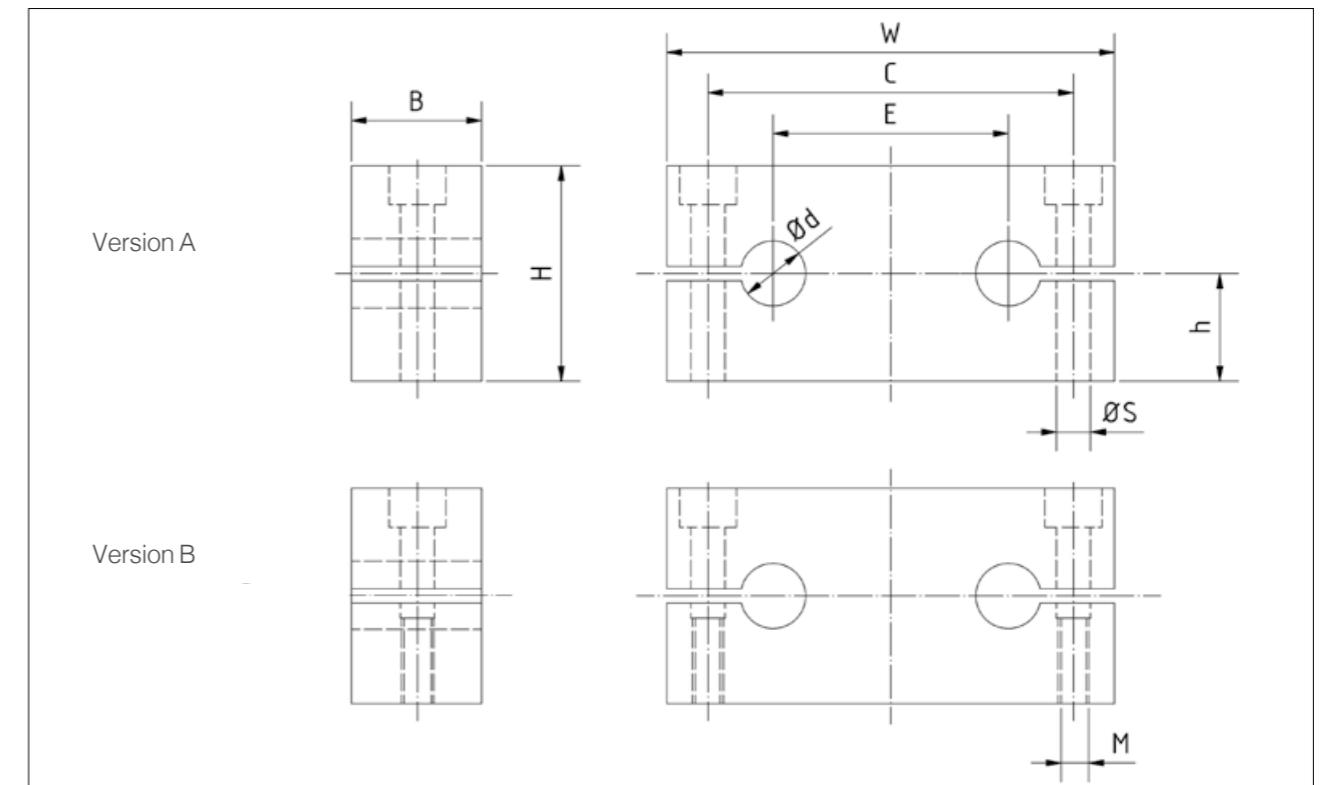

Order reference		Dimensions [mm]											Weight [g]
		Ød	W	B	H		h ±0,015		C	ØS	M	E	
Version A	Version B				Version A	Version B	Version A	Version B					
SH8A	SH8B	8	65	12	23	22	12,5	11	52	5,5	M5	32	40
SH12A	SH12B	12	85	14	32	28	18	14	70	6,6	M6	42	70
SH16A	SH16B	16	100	18	36	32	20	16	82	9	M8	54	130
SH20A	SH20B	20	130	20	46	42	25	21	108	11	M10	72	220
SH25A	SH25B	25	160	25	56	52	30	26	132	13,5	M12	88	440
SH30A	SH30B	30	180	25	64	58	35	29	150	13,5	M12	96	560
SH40A	SH40B	40	230	30	80	72	44	36	190	17,5	M16	122	1 000

Shafts

Matrix in function of the pre-selection of solid shafts and hollow shafts

Model	Material	Available shaft diameter [mm]	Standard tolerance of shaft
Solid shaft	Cf53 (1.1213)	4, 5, 6, 8, 10, 12, 16, 20, 25, 30, 35, 40, 50, 60	h6
	X90CrMoV18 (1.4112)	12, 16, 20, 25, 30, 35, 40	h6
	Cf53 (1.1213) hard-chrome plated	12, 16, 20, 25, 30, 35, 40	h7
	X46Cr13 (1.4034)*	12, 16, 20, 25, 30, 35, 40	h6
Hollow shaft	C60 (1.1221)	12, 16, 20, 25, 30, 40, 50, 60	h6

Supply of standard products from stock.

*Please note the limited life duration (s. page 78)..

The other models are available upon request.

Steel, surface hardness, depth of hardness

The surfaces of the shafts are induction hardened. The even hardness penetration depth ensures the constant transition of the hardened outer zone from out of the tough, normalized core, capable of coping with bending stress (loads).

Shaft diameter [mm]	from	4	10	18	30	50
	up to	10	18	30	50	80
Min. hardness penetration depth [mm]		0,4	0,6	0,9	1,5	2,2

- Heat-treated steel Cf53 (1.1213) with surface hardness HRC 62±2
- Stainless and acid-resistant steel X90CrMoV18 (1.4112) with surface hardness HRC 57±2
- Hard-chrome plated heat-treated steel Cf53Cr (1.1213) with surface hardness 900-1100 HV
- Stainless steel X46Cr13 (1.4034) with surface hardness HRC 55±2
- Hard-chrome plated heat-treated steel Ck60 (1.1221) with surface hardness HRC 60, thickness of chromium layer apx. 10 µm, apx. 1000 HV

Dimension accuracy and tolerance field

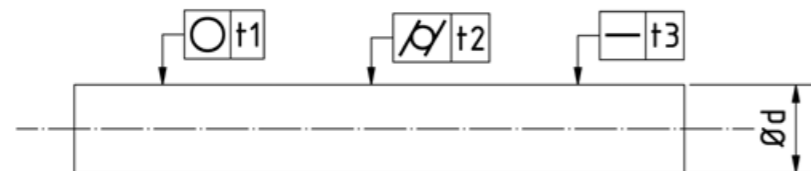

Nominal diameter [mm]	from	4	6	10	18	30	50
	up to	6	10	18	30	50	80
Roundness tolerance t1 [µm]		4	4	5	6	7	8
Concentricity tolerance t2 [µm]		5	6	8	9	11	13
Straightness-tolerance t3 [µm/m]		150	120	100	100	100	100
Mean deviation [µm]		0,32	0,32	0,32	0,32	0,32	0,32

Details for standard product Cf53 (1.1213)

Solid shafts

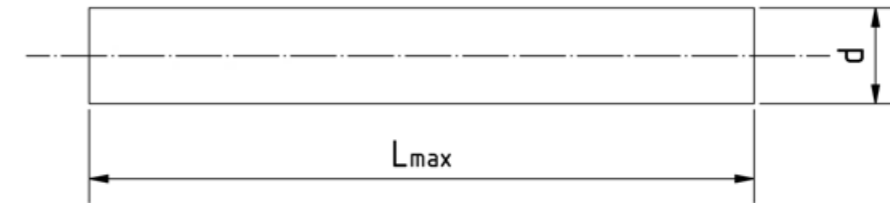

Order reference	W04	W05	W06	W08	W10	W12	W16	W20	W25	W30	W35	W40	W50	W60
Diameter d [mm]	4	5	6	8	10	12	16	20	25	30	35	40	50	60
Max. length L [mm]	3600	4000	4000	4000	4000	6000	6000	6000	6000	6000	6000	6000	6000	6000
Mass [kg/m]	0,099	0,154	0,222	0,395	0,617	0,888	1,578	2,466	3,853	5,549	7,552	9,864	15,413	22,195

Details for standard product Cf53 (1.1213)

Hollow shafts

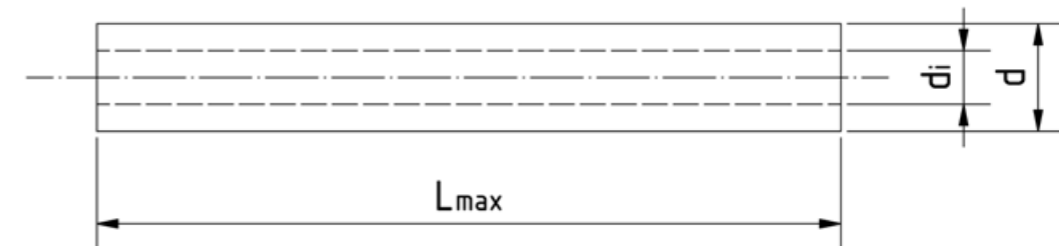

Order reference	HW12	HW16	HW20	HW25	HW30	HW40	HW50	HW60
Diameter d [mm]	12	16	20	25	30	40	50	60
Internal diameter di [mm]	3,4	8	14	14	19	26,5	29,6	36,5
Max. length L [mm]	6000	6000	6000	6000	6000	6000	6000	6000
Mass [kg/m]	0,817	1,184	1,258	2,645	3,323	5,535	10,011	13,981

Details for standard product Ck60 (1.1221)

Shaft tooling

Addition tooling (eg. taps, internal and external threads, countersinks) which require annealing may display minor dimensional changes.

Length tolerance for shortened shafts

Shaft length L [mm]		Max. tolerance [mm]
from	to	
-	400	±0,5
400	1000	±0,8
1000	2000	±1,2
2000	4000	±2,0
4000	6000	±3,0

Combination 00 Standard order

After cutting, the shafts are only shortened and deburred, no further dressing of the end is carried out.

Combination 01 Standard stage

The shafts are chamfered on both ends after the shortening, preventing the occurrence of damage to the ball cage or seals, in case of contact with the ball bushings.

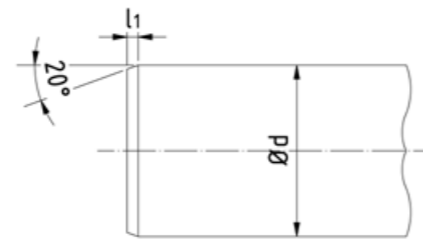

Ød [mm]	4	5	6	8	10	12	16	20	25	30	35	40	50	60
l1 [mm]	1	1,5	1,5	1,5	1,5	2	2	2	2	2	2	3	3	3

Combination 02 Axial thread

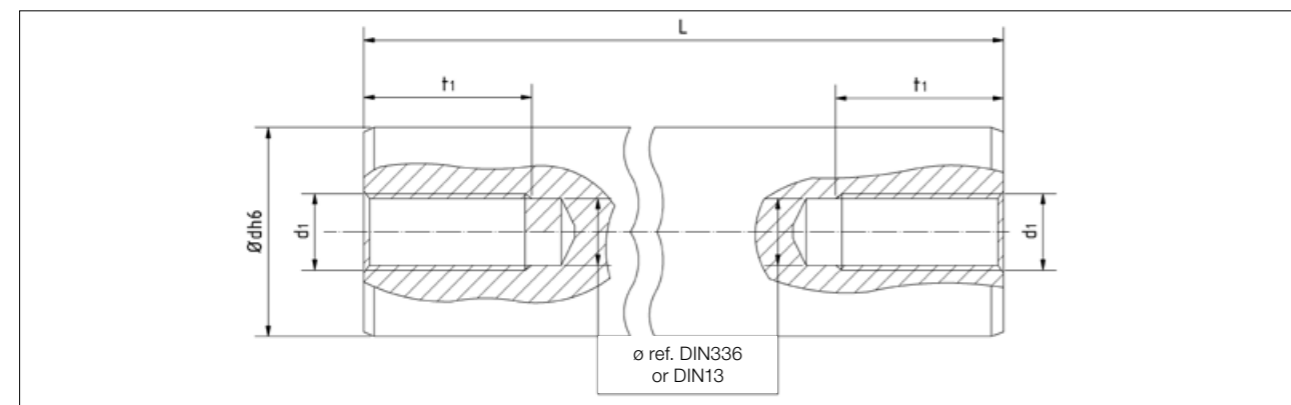

Ød [mm]	12	16	20	25	30	40	50
d1 [mm]	M5	M6	M8	M10	M12	M12	M16
t1 [mm]	12,5	16	19	22	28	28	36

Combination 03 Axial thread and center bore, according to DIN 332-D

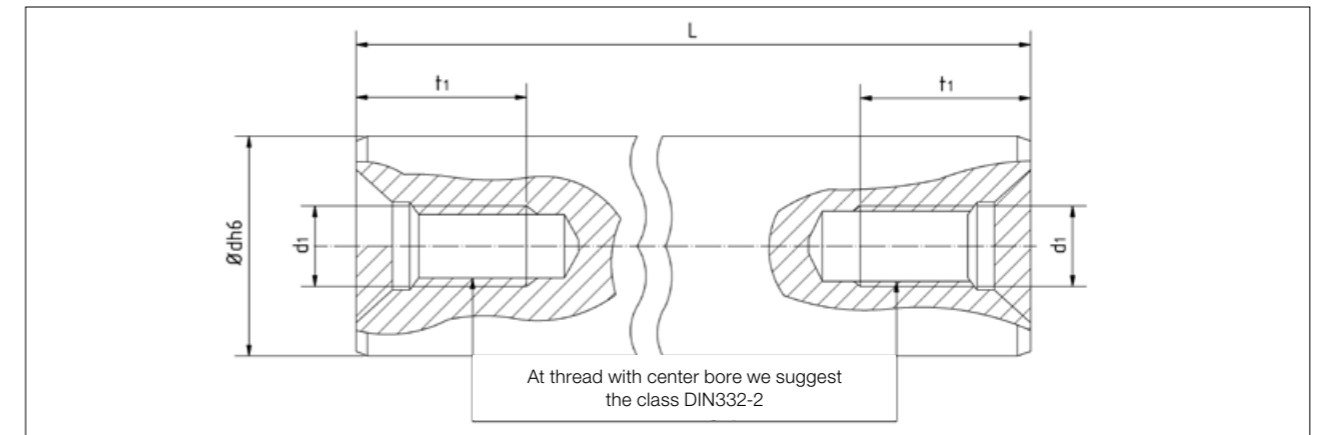

Ød [mm]	12	16	20	25	30	40	50
d1 [mm]	M5	M6	M8	M10	M12	M12	M16
t1 [mm]	12,5	16	19	22	28	28	36

Combination 04 Radial holes (bores) with and without thread

In case steel shafts have to be supported, radial bores are necessary.

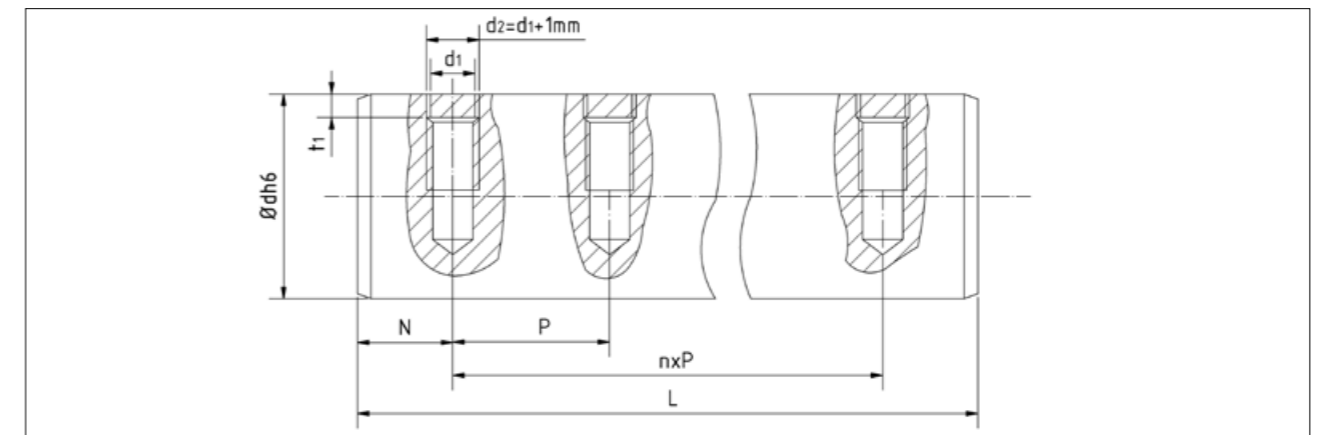

Ød [mm]	12	16	20	25	30	40	50
d1 [mm]	M4	M5	M6	M8	M10	M10	M12
t1 [mm]	2,5	2,5	3,0	3,0	3,5	4,0	4,0

The hole distance depends on the shaft diameter. The tables for the shaft supports display the reference data.

Combination 05

Axial thread (combination 02) and radial bores with and without thread (combination 04).

Combination 06

Axial thread and center bore, according to DIN 332-D (combination 03) and radial bores with and without thread (combination 04).

Examples of tooling

Please use your own customer drawing for a request, or copy our model and complete with the required data (values).

Insertion for locking ring, according to DIN 471

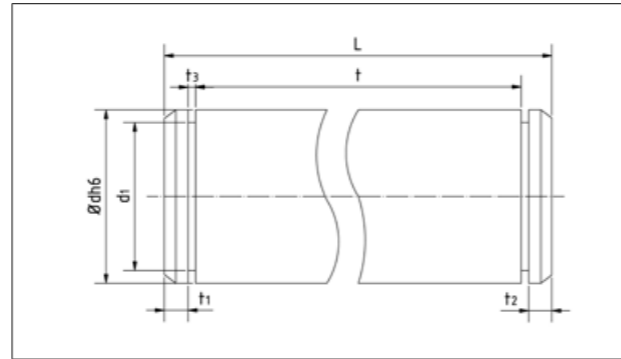

Insertion 90°

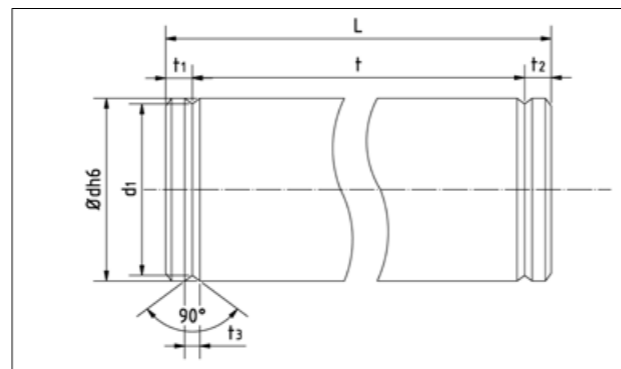

Width across flat

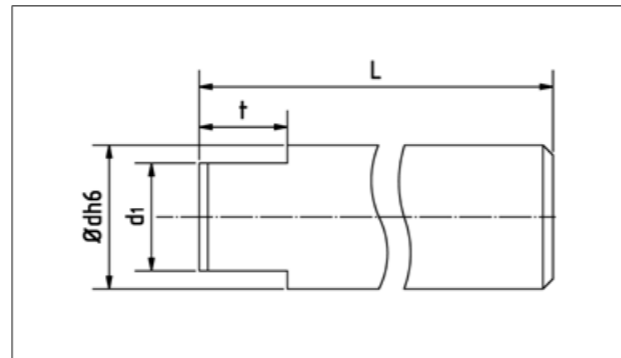

Width flat

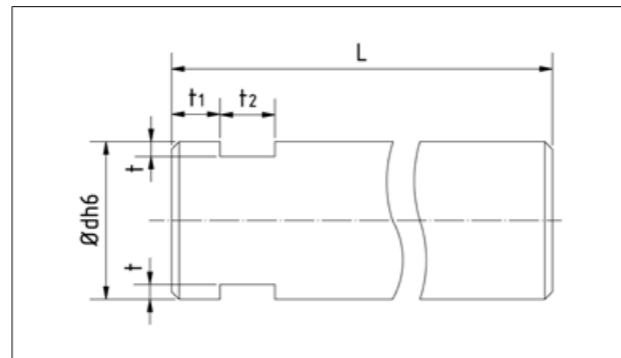

Taps

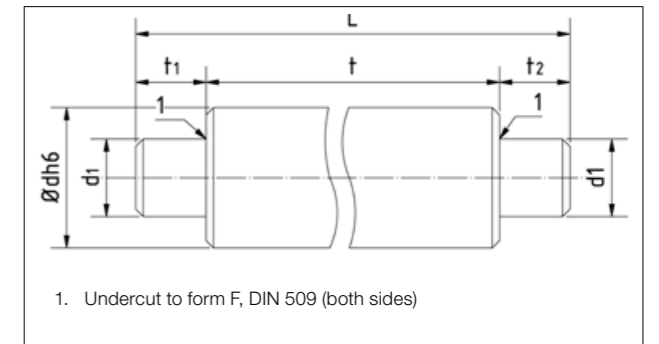

Threaded ends

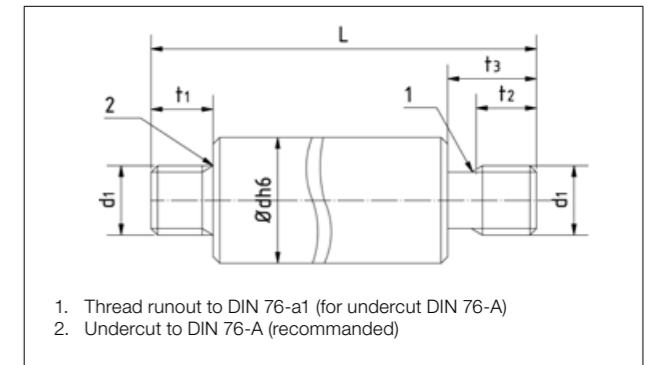

Taps and threaded ends

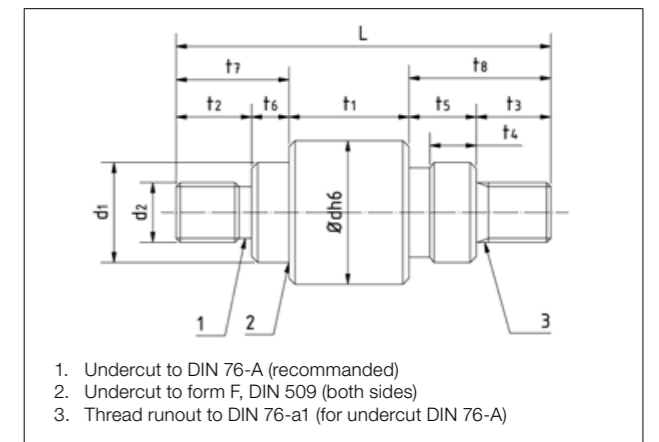

Notch

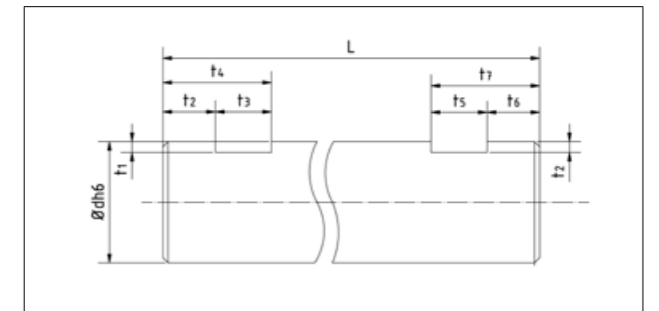

Surface

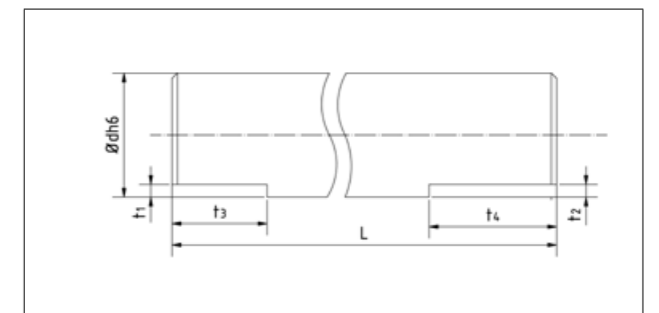

Type designation code

BBE... ball bushings and BBET... super ball bushings

- Examples of order reference for ball bushings/super ball bushings without seal:
BBE20, BBET20
- Examples of order reference for a ball bushings/super ball bushings with single-sided seal:
BBE20U, BBET20U
- Examples of order reference for a ball bushings/super ball bushings with double-sided seal:
BBE20UU, BBET20UU

KH ball sleeves

- Example of order reference for a ball sleeve without seal:
KH1228
- Example of order reference for a ball bushings with double-sided seal:
KH1228LL/3AS

Linear units with standard ball bushings (norm)

- Example of order reference for linear units with standard BBE ball bushings with double-sided seal:
LSE20UU

Linear units with super ball bushings

- Examples of order reference for linear units with super ball bushings with double-sided seal:
LSET20UU

Shafts/hollow shafts

W 20 - 6000 - 0 - 04 - 04 - N37,5 - P1
 1 2 3 4 5 6 7

1	W20	Type of shaft (W – solid shaft, HW- hollow shaft) and diameter (mm)
2	6000	Length of shaft (mm)
3	0	Material/finishing of the shaft/hollow shaft
		0 Cf53 (for W), C60 (for HW)
		1 X90CrMoV18 Inox
		2 Cf53 hard-chrome plated
	3 X46Cr13 Inox	
4	04	Shaft tooling (00...06, XX- according to design by customer)
5	04	Shaft tooling (00...06, XX- according to design by customer)
6	N37,5	N Measure [mm]
		P Measure [mm]
		P0 Standard measure according to catalog for SR10, SR30, SR40
		P1 Standard measure according to catalog for SR20
7	P1	P2 Standard measure according to catalog for SR20

Position 6 and 7 only for the shaft tooling combination 04, 05 and 06!

Shaft supports with/without shaft

SR20 - 16 - 1199 - N37,5 - P1 - W - 0 - 04 - 04
 1 2 3 4 5 6 7 8 9

1	SR20	Model of the mounting rail
2	16	Diameter of the shaft (mm)
3	1199	Length of the mounting rail (mm)
4	N37,5	N Measure [mm]
		P Measure [mm]
5	P1	P0 Standard measure according to catalog for SR10, SR30, SR40
		P1 Standard measure according to catalog for SR20
		P2 Standard measure according to catalog for SR20
6	W	Without Without shaft
		W Solid shaft
		HW Hollow shaft
7	0	Material/finishing of the shaft/hollow shaft
		0 Cf53 (for W), C60 (for HW)
		1 X90CrMoV18 Inox
		2 Cf53 hard-chrome plated
	3 X46Cr13 Inox	
8	04	Shaft tooling (00...06, XX- according to design by customer)
9	04	Shaft tooling (00...06, XX- according to design by customer)

Position 6 to 9 only if with shaft/hollow shaft!

General information

Introduction

Linear ball bushings achieve longitudinal movement along a shaft by retaining the balls in a closed circulation path, allowing constant recirculation through the load zone. Hence, unlimited lifting heights/strokes are possible. The ball bushings offer the advantages of any journal (ball) bearing, namely a long operational life, low friction and breakaway torque, high precision and efficiency. The surfaces of the bearings are made from high-grade rolling bearing steel. The precisely shaped and polished cylindrical sheet-metal outer ring consists of one single part. It is held together by way of turned parts, screwed into the bushing/case and combining the function of smooth sealing rings through their design. Therefore, standard bearings with wiper seals can often be utilized. A unit with high rigidity, functional reliability and sustainability is achieved.

Load ratings

Dynamic load rating C

The radial load with constant magnitude and direction, a linear-rolling bearing can theoretically cope with for a nominal operational period of 10^5 m covered distance.

Remark: The details of the dynamic load rating stipulate that the lift of the linear-joint (ball) bearings should be at least three times its overall constructional length.

Static load rating C_0

Static radial load results in deformation at the contact zones with the highest load/stress between the rolling element and the orbital path (shaft) of 5300 Mpa.

Remark: The permanent overall deformation of the rolling element and the orbital path corresponds approximately to a factor of 0,0001 of the diameter of the rolling element.

Permissible load

Comparison between permissible loads in standard ball bushings and tandem models

Type	Dynamic load rating	Static load rating	Permissible static moment
BBE...*	1	1	1
BBE...L	1,6	2	~ 6

*For comparative purposes, standard type BBE is set as '1'.

Relation between the rows of balls and the load rating

Closed and adjustable ball bushings

Number of rows of balls	4	5	6
C (load rating according to Table)			
C_{max} (maximal load capacity)			
Load coefficient C_{max}/C	1,414	1,463	1,280

The load capacity of a ball bearing (closed and adjustable) varies depending on the reference point of the load (and) on the circumference (size). The value in the Tables indicates the smallest load rating assuming a load working from/on the topside of a ball element. Where two ball elements are utilized that are being evenly loaded, the value increases. The Table above displays the values for the number of ball elements in each of the cases.

Open ball bushings

Number of rows of balls	3*	4	5
Load from above			
	C_{0max}	C_{0max}	C_{0max}
Load from below			
	$C_0=0,64C_{0max}$	$C_0=0,54C_{0max}$	$C_0=0,57C_{0max}$

*Except the types with three rows, with a steel cage.

Where a load is applied in the open direction, the load capacity (rating) is reduced, because the load is working on a smaller number of rows of balls.

Material

Depending on the application, various models of ball bushings may be utilized.

Standard ball bushings of the BBE series consist of the following:

- A hardened and polished outer sleeve (100Cr6)
- A guidance cage made from plastic (POM)
- Balls made from ball-bearing steel (100Cr6)
- Wiper seals made from NBR (optional)

These ball bushings have as distinctive advantages for instance reduced noise during operation and a cost-efficient model.

Standard ball bushings of the BBE...A series consist of the following:

- A hardened and polished outer sleeve (100Cr6)
- A guidance cage made from austenitic stainless steel (X2CrNi 18-9)
- Balls made from ball-bearing steel (100Cr6)
- Wiper seals made from NBR (optional)

Potential applications: high temperatures, for instance in foundry applications or applications involving vacuum, where the utilization of plastic parts is not feasible.

The corrosion-resistant ball bushings of the BBES series consist of the following:

- A hardened and polished outer sleeve made from martensitic stainless steel (X105CrMo17)
- A guidance cage made from plastic (POM)
- Balls made from ball-bearing steel (100Cr6)
- Wiper seals made from NBR (optional)

Potential applications: corrosive environments.

The corrosion-resistant ball bushings of the BBES...A series consist of the following:

- A hardened and polished outer sleeve made from martensitic stainless steel (X105CrMo17)
- A guidance cage made from austenitic stainless steel (X2CrNi 18-9)
- Balls made from ball-bearing steel (100Cr6)
- Wiper seals made from NBR (optional)

The ball bushings of the BBES...A series are specifically intended for use under extremely dirty conditions, for instance cement works or the wood processing industry. A further potential area of application is the industry in which aggressive cleaning agents are used (e.g. the food industry, chemical industry, pharmaceutical and medicinal industry).

Super ball bushings of the BBET... series consist of the following:

- A guidance cage and outer sleeve made from POM
- Hardened steel inserts with polished orbital path groove (15CrMo5)
- Balls made from ball-bearing steel (100Cr6)
- Wiper seals made from NBR (optional)

The high-grade super ball bushings of the BBET series distinguish themselves from the conventional ball bushings by a triple load capacity and by an operational life that is 27 times as long as the normal one.

The ball bushings of the KH... series consist of the following:

- A hardened sleeve, shaped without cutting (chipless)
- A guidance cage made from plastic (POM)
- Balls made from ball-bearing steel (100Cr6)
- Wiper seals made from NBR (optional)

Ambient temperature during operation

Material		Name	Temperature range
Outer sleeve	Cage		
Steel	Plastic	BBE...	-20 °C ~ 80 °C (-4 °F ~ 176 °F)
	Steel	BBE...A	-20 °C ~ 110 °C (-4 °F ~ 230 °F)
Stainless steel	Plastic	BBES...	-20 °C ~ 80 °C (-4 °F ~ 176 °F)
	Steel	BBES...A	-20 °C ~ 140 °C (-4 °F ~ 284 °F)*

*When using a ball bearing with seals, the ambient temperature should not exceed 120 °C (248 °F).

Service life

Nominal service life

The nominal service assumes a 90% certainty for achievable service life for a single rolling bearing or a group consisting of similar rolling bearings, running under the same conditions, with standard material of normal production quality and under standard operating conditions.

The sizing of the ball bearing is determined by the required service life and load. The service life of the ball bushings is calculated in the same manner as all rolling bearing, using the following formula:

$$L = \frac{C}{F} \cdot \frac{f_H \cdot f_T \cdot f_C}{f_W} \cdot 50$$

L Nominal service life [km]
 C Dynamic load rating [N]
 F Dynamic load [N]
 f_H Hardness factor of the shaft hardness (standard 1)
 f_T Temperature factor
 f_C Contact factor
 f_W Load factor

$$L_h = \frac{C}{F} \cdot \frac{L}{2 \cdot s \cdot n_s \cdot 60}$$

L_h Nominal service life [h]
 s Stroke length [m]
 n_s Stroke frequency [min⁻¹]

Hardness factor for shaft hardness f_h

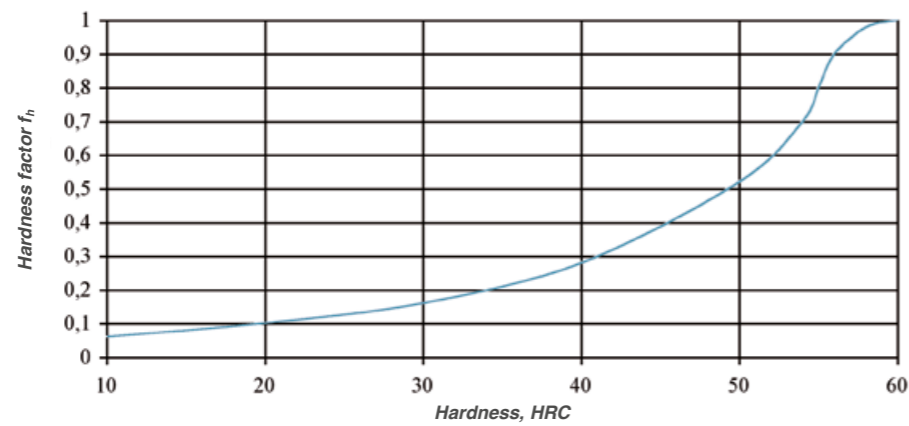

If shafts are utilized with a hardness of the surfaces of less than 60 HRC, a hardness factor is to be taken into account.

Temperature factor f_t

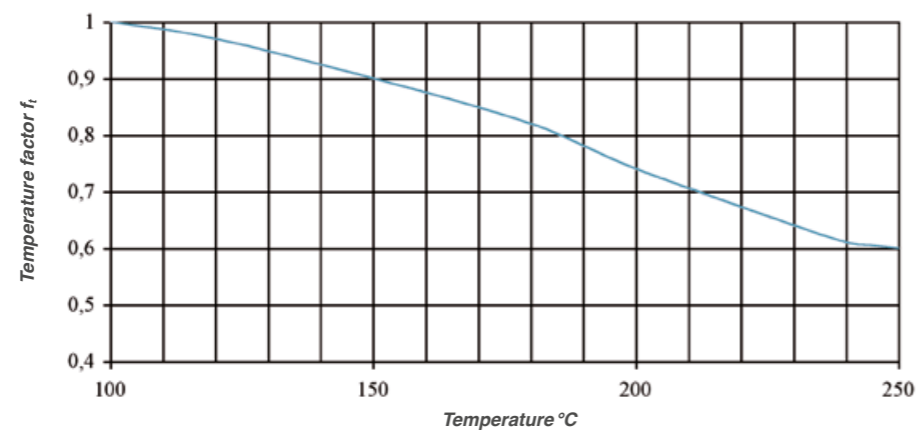

If the ambient temperature of the ball bushings exceeds 100°C (212°F) during operation, negative effects from the high temperatures must be taken into account. Moreover, the respective ball bearing has to be suited for high temperature ranges.

Contact factor f_c

If multiple ball bushings are put closely together, the running motion is influenced by moments and the mounting precision, in such a way that an equal load distribution is very hard to achieve. In such a case, a contact factor is to be taken into account.

Number of ball bushings closely put together	f_c
1	1,0
2	0,81
3	0,72
4	0,66
5	0,61

Load factor f_w

In general, machines with oscillating movements cause vibrations and shocks during their operation. Generally, it is quite hard to exactly determine the vibrations and shock loads, caused by repeated starting and stopping, during operation at high speeds. If the loads acting on the ball bushings cannot be measured or in case of high speed and shock loads having a large influence, the appropriate load factor has to be applied.

Operating conditions, speed V	f_w
Normal operating conditions, $V \leq 0,25$ m/s	1,0...1,5
Normal operating conditions with limited vibrations/shocks, $0,25 < V \leq 1,0$ m/s	1,5...2,0
Operating conditions with strong vibrations/shocks, $V > 2,0$ m/s	2,0...3,5

Static safety coefficient f_s

The static safety factor f_s is used to prevent unacceptable permanent deflections of the raceways and rolling elements. It is the relation between the static load capacity rating C_0 and the maximum occurring load F_{0max} . The maximum load condition including transient conditions is assumed.

$$f_s = \frac{C_0}{F_{0max}}$$

f_s Static safety coefficient
 C_0 Static load rating [N]
 F_{0max} Maximum static load [N]

References for the static safety coefficient in case of various operating conditions:

Operating conditions	f_s
Normal operating conditions	1 ... 2
Limited shock loads and vibrations	2 ... 4
Moderate shock loads or vibrations	3 ... 5
Strong shock loads or vibrations	4 ... 6
Load parameters are unknown	6 ... 15

Lubrication and friction

The friction levels for ball bushings without wiper seals are quite low, at approx 0.001 to 0.003. The general rolling bearing criteria apply to the lubrication. Lubrication can be mineral based oil or grease and the following is to be taken into account. The grease enhances the sealing and adheres to the ball bearing. Further lubrication is only necessary over longer intervals. Contrary to ball screws and track rail guides, substantially less lubricant is required for ball bushing guides, due to the limited contact surface between the rolling bearing and the orbital path.

We recommend mineral based grease of K2K DIN 51825 quality. In case of loads that are more than 10 % higher than the dynamic load capacity rating, greases with EP additives are to be used (KP2K DIN 51825). The ball bushings as standard are treated and delivered with an oily preservative. The preservative can be used with and can be combined with lubricants having an oily basis, so that in general the bearing does not have to be washed before installation.

Under normal circumstances, grease SNR LUB EP is used. Specific requirements under certain environmental conditions require the use of suitable grease. In vacuum applications, lubricants are required that have a lower evaporation rate, in order to keep the vacuum atmosphere in good order. In the food industry and cleaning room, there are special requirements for the lubricant with regard to emission and compatibility. Basically the compatibility of the lubricants in relation to each other should be checked. In case of special ambient conditions, we will gladly assist you.

Designation	Type of oil, consistency regulator	NLGI class DIN 51818	Walk-penetration DIN ISO 2137 at 25 °C (77 °F)	Base oil viscosity DIN51562 at 40 °C (104 °F)	Density [kg/m ³]	Temperature range	Properties	Range of application
			[0,1 mm]	[mm ² /s]		[°C]		
SNR LUB Heavy Duty	- Paraffinic mineral oil - Lithium-special-soap	2	285	apx. 105	890	-30...+110	- Low friction - Smooth running	- General mechanical engineering
SNR LUB GV+	- Synthetic 'KW' oil - Ester oil - Lithium-special-soap	2	265...295	24	900	-50...+120 °C (-58°F...248 °F)	- Very good adhesive power - Highly water-resistant	- High speeds
SNR LUB HIGH TEMP	- Synthetic 'KW' oil - Mineral oil - Polyurea	2	265...295	160	900	-40...+160 °C (-40°F...320 °F)	- High heat resistance - Good corrosion protection - High oxidation resistance	- High temperature range
SNR LUB FOOD	- Paraffinic mineral oil - Aluminium complex soap	2	265...295	apx. 240	920	-30...+110	- Good corrosion protection - Very good adhesive power - High water resistance - NSF H1 registered*	- Food industry
Microlub GL261	- Mineral oil - Lithium special-soap	1	310...340	280	890	-30...+140	- Good wear protection - Highly pressure-resistant - Additive against fretting corrosion	- General mechanical engineering - Heavy load applications - Short-stroke applications - Vibrations
Klübersynth BEM34-32	- Synthetic 'KW' oil - Special - calcium soap	2	265...295	apx. 30	890	-30...+140	- Highly pressure-resistant - Good wear protection - Good durability - Low starting torque	- Clean room applications
Klübersynth UH1 14-151	- Synthetic 'KW' oil - Ester oil - Aluminium - complex soap	1	310...340	apx. 150	920	-45...+120	- Good corrosion protection - Good durability - High water resistance - NSF H1 registered*	- Pharmaceutical industry - Food industry

*This grease is registered as H1 product: it has been developed for occasional, technically unavoidable contact with foodstuff. Experiences have shown that the grease can also be used for the corresponding applications in the pharmaceutical and cosmetic industry, on the conditions listed in the product information. However, there are no specific test results, for instance, on the biocompatibility, as may be required under certain circumstances in the pharmaceutical area. Therefore, before it is used in this area by equipment manufacturers and distributors, corresponding risk analyses must be performed. If necessary, measures to avoid health hazard and injuries must be taken. (Source: Klüber Lubrication).

In case of the initial lubrication and further lubrication through the lubricating hole, lubricant has to be applied to the bearing in installed shafts until it abundantly 'fills' the bearing.

The lubrication period depends on many influential factors, for instance:

- Load
- Speed
- Motion sequence
- Temperature

The following influential factors reduce the lubrication interval:

- Greater load
- High speed
- Short stroke (stroke is shorter than three times the length of the ball bearing)
- Lower ageing resistance of the lubricant

Precise lubrication intervals can be obtained upon request, based on the operating conditions.

Fittings

In general, in case of standard ball bushings, the normal clearance fit is applied. The transition fit is used, in order to reduce the play and increase the accuracy. The pre-tension for the adjustable and open ball bushings must be set according to the values displayed in the table for the radial play (clearance), so that the allowable limit values for the pre-tension cannot be exceeded.

In case of the super ball bushings, it has to be taken into account that adequate play (clearance) occurs between the super ball bearing and the shaft. If that is not the case, early failure and/or jerky movements may be caused.

Series	Shaft		Casing	
	Clearance fit	Transition fit	Clearance fit	Transition fit
BBE...	h6	j6	H7	J7
BBE...L	h6	-	H7	-
BBER...	h6	j6	-	-
BBER...L	h6	-	-	-
BBET...	h6	-	H7	-

Standard ball bushings are otherwise inserted in a H7 bore and retained by way of locking rings. Alternatively, they can and may also be fixed or adhered by way of screwed disks, locking plates or washers.

Using complete bearing units in which the bearings have already been installed eliminates fitting concerns and offers a significant cost benefit.

MORE INFORMATION CONCERNING OUR PRODUCTS FOR LINEAR MOTION IS PROVIDED IN OUR CATALOGUES.



www.ntn-europe.com/documents/linear

NTN

Make the world **NAMERAKA**



DOC_LBBUSHING_CAT1_GBa - Document non contractuel - NTN Europe copyright international - 04/24 - Photos: NTN Europe - Pedro Studio Photos

This document is the exclusive property of NTN Europe. Any total or partial reproduction hereof without the prior consent of NTN Europe is strictly prohibited. Legal action may be brought against anyone breaching the terms of this paragraph.
NTN Europe shall not be held liable for any errors or omissions that may have crept into this document despite the care taken in drafting it. Due to our policy of continuous research and development, we reserve the right to make changes without notice to all or part of the products and specifications mentioned in this document.
© NTN Europe, international copyright 2024.

NTN Europe - 1 rue des Usines - 74000 Annecy
RCS ANNECY B 325 821 072 - Code APE 2815Z - Code NACE 28.15
www.ntn-europe.com

