



GA355.16/GB-07/2022

GA355.16

Assembly/disassembly recommendations

	ENGINES	OE REFERENCE
NISSAN: Primastar (I et I FL), Interstar (I et II), Kubistar	2.2 dCi/Cdi,	11955-00QAA, 11955-00QAD, 11955-00QAE, 8200761529 4413416, 4431739,4405281
RENAULT: Avantime, Espace (II FL, IV et IV phase 2), Laguna (II et II phase 2), Master (II, II FL et II phase 2 FL), Trafic (II et II FL), Vel Satis (I et I FL)	2.5 dCi, 2.2 DTI, 2.5 CDTI, 2.5 DTI	
OPEL: Movano, Vivaro		

IDENTIFICATION OF TENSIONER ROLLER GA355.16



Traceability

COMMON FAILURES INVOLVING ROLLER GA355.16

PROBLEMS WITH RUNNING NOISE AND DAMAGED ROLLERS

Probable cause

A defective alternator overrunning pulley

When worn or seized the overrunning alternator pulley does not disengage correctly, this means the alternator can't free wheel when needed. This generates an up and down snatching motion on the belt.

GA355.16 is not designed to absorb the violent shocks caused by the belt, this allows the belt to become incorrectly tensioned allowing it to slip on the rollers (FIG 1).

The slipping belt creates heat on the outer diameter of the tensioner roller pulley. This causes a rise in temperature inside the pulley, causing it to fail.

Another sign of an overrunning alternator pulley failure is the tensioner roller assembly stop shows traces of impact and is generally damaged normally bent. This failure is associated with excessively large roller displacement (Fig 2).



Failures with GA355.16 are often caused by a faulty overrunning alternator pulley. Overrunning alternator pulleys should be checked or replaced at the same time as the tensioner roller assembly is replaced.

Tests to verify the condition of the overrunning alternator pulley

- Engine idling: look to see if the tensioner shows any abnormal movements such as a bouncing up and down movement which makes the belt move up and down
- Engine stopped, belt removed, stop the alternator rotor from turning (use a nonmetal object to block it). Rotate the pulley by hand, it should only turn in one direction, if it turns in both directions or will not turn in either direction the overrunning alternator pulley should be changed

REPLACEMENT

Note - Belts should not be re-used after being removed, a new belt should always be fitted when the tensioner pulleys are replaced or refitted.



Removal

- 1) Rotate the tensioner clockwise to release the tension on the belt (no. 1)
- 2) Install the tensioner locking tool (Fig 2)
- 3) Tool no. KM-6130
- 4) Remove the belt
- 5) Remove the tensioner bolts (Fig 3)
- 6) Remove the tensioner roller

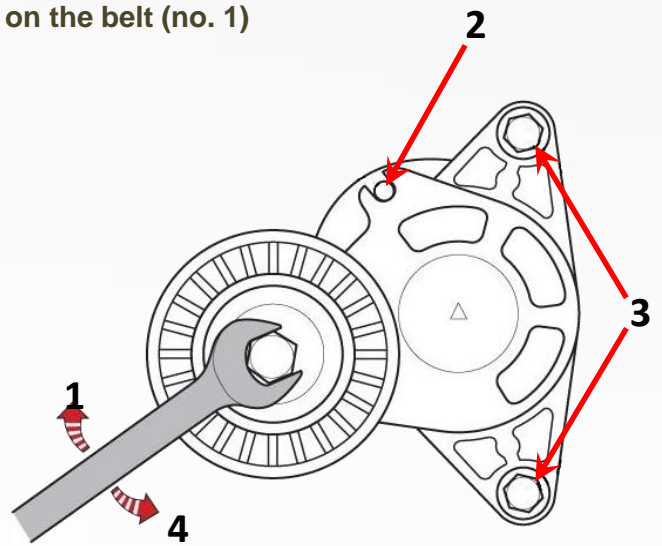

RE-INSTALLATION

- 1) Install the new tensioner roller
 - 2) Install the tensioner roller bolts (Fig 3)
- Tightening torque: 25 Nm
- 3) Install the new belt
 - 4) Apply tension to the tensioner roller in the clockwise direction (no. 1)

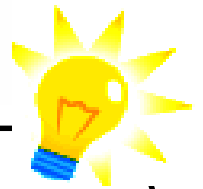

Recommendations

The overrunning alternator pulley is a wearable part. Regular checks should be made to verify that it is functioning correctly.

Manufacturers recommend replacing tensioner rollers and pulleys along with the accessory belt at 75000 mile intervals.

At that same time, it is strongly recommended that the overrunning alternator pulley is replaced.

Follow the vehicle manufacturer's installation procedures and apply the specified tightening torques.

Refer to the vehicle applications in our online catalogue: [eshop](#)



Scan this QR code to access our online catalogue.

FOLLOW THE RECOMMENDATIONS OF THE VEHICLE MANUFACTURER.

©NTN-SNR Roulements

The contents of this document are the copyright of the publisher and any reproduction, even partial, is prohibited without permission. Despite the care taken in preparing this document, NTN-SNR Roulements disclaims any liability for errors or omissions that may slip through, as well as for losses or direct or indirect damage arising from its use.

