



# R154.13

## Disassembly / Assembly recommendations

<b>AUDI :</b>	50, 80 (81, 89-8A), 90 (81, 85, 89,8A), Coupé 85	<b>OE reference</b> 191598625, 6U0598625
<b>SEAT :</b>	Arosa, Cordoba (I and II), Ibiza (II and II FL1), Toledo series 1	
<b>SKODA :</b>	Favorit, Felicia, Felicia FL, Forman	
<b>VOLKSWAGEN :</b>	Caddy II, Coccinelle/Beetle, Corrado, Derby, Golf (I, II and III), Fox, Jetta (I and II), Passat (I, II, III and IV), Polo (I, II, III, IV and V), Santana, Scirocco, Vento, Golf Cabriolet (Golf I, II and III)	

### IDENTIFICATION OF WHEEL KIT R154.13



## COMMON PROBLEMS WITH THIS KIT

### PROBLEMS WITH RUNNING NOISE

### PROBABLE CAUSE

#### Operation with the incorrect amount of grease.

If an insufficient quantity of grease is applied, or the grease is not applied between the raceways and the rolling elements, damage to the raceway will occur.



The bearings need to be carefully greased before fitting (see item 1 in the "Re-installation" page 3)

### Failure to replace the outer rings (cup).

It is absolutely imperative to replace both the cup and cone assemblies, the cups and cones are paired and must be fitted together.

### Over-tightening of the stub axle bolt.

This raises the temperature inside the bearing, breaks down the grease in contact with the rolling elements and causes spalling damage to the raceways.

As a result, the bearing seizes, causing the cage to break up (**no. 1**) and destroy the bearing.



### Operation with a bent stub axle.

This problem can occur due to wear or by over tightening of the stub axle nut.

As a result the seating of the inner rings on the stub axle is changed, which leads to spalling (**no. 2**) and bearing failure.



It is essential to inspect the stub axle and replace it if it is bent or damaged in any way, failure to do so will lead to a rapid failure of the newly fitted bearing.

## REMOVAL

- 1) Place the rear of the vehicle on jack stands and remove the wheel from the side to be serviced
- 2) Make sure that the parking brake is released
- 3) Remove the grease cap
- 4) Remove the cotter pin and the bolt
- 5) Unscrew the hub bolt and remove the washer
- 6) Remove the drum
- 7) Pry off the inner seal ring (no. 3)

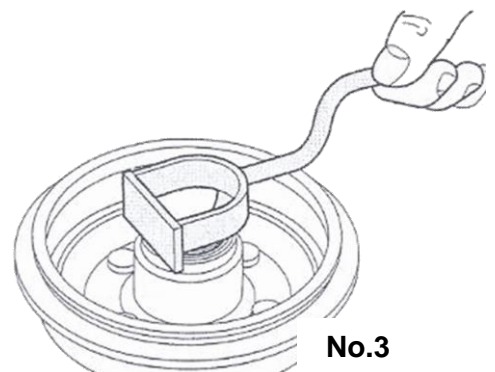

8) Extract the inner and outer bearing cups (no. 4)



9) Clean and inspect the fit of the bearing in the drum and the surface of the stub axle.

Replace any worn parts (for example: signs of wear or seizure on the stub axle)

## RE-INSTALLATION

1) Grease each new bearing with its outer ring (20 g of grease in the bearing and 20 g of grease in the seat of the drum)  
Only bearing grease should be used (do not use greases containing graphite or copper)

2) Use a suitable mandrel, press the outer ring of the inner bearing all the way into the drum (no. 5)

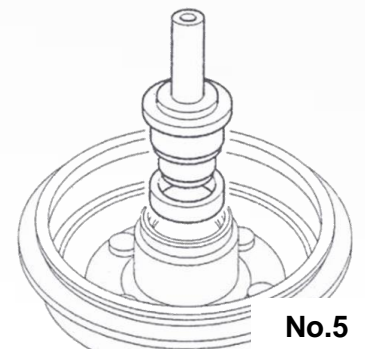

3) Press the outer ring of the outer bearing  
Make sure the bearing outer is pressed all the way into the drum using the same mandrel.

4) Apply bearing grease to the lip of the new inner seal ring  
Use a mandrel with a suitable diameter to install the ring (no. 6).

5) Install the inner bearing on to the stub axle

6) Re-install the drum

7) Install the outer bearing, then the washer

8) Tighten the bolt (do not use an impact wrench), then adjust the play

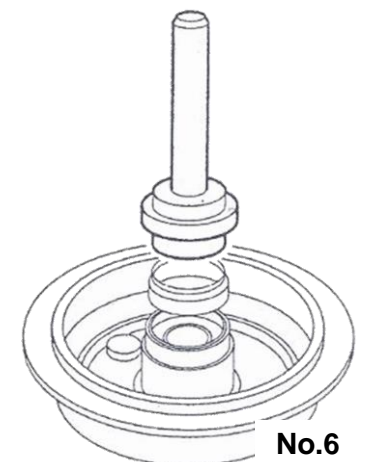

Always rotate the drum while tightening the stub axle nut, in order to ensure the correct alignment of the rolling elements.



- Tighten the centre bolt carefully with a torque wrench.  
Tightening torque: **110 Nm**
- Once tightened to **110Nm** loosen the bolt slightly until you can just move the thrust washer radially with your fingertips (or with the tip of a screwdriver, make sure you don't pry anything out). This gives the bearing its correct amount of clearance.  
This can also be verified with a comparator (around 0.01 to 0.02 mm **no. 7**).

**9) After adjustment, fix the bolt in place with a castellated retainer and a new cotter pin**

**10) Install the new grease cap after having filled it with 15 g of grease**

**11) Finally, test drives the vehicle for a few miles and recheck the play in the bearing to make sure the bearing play is correct.**

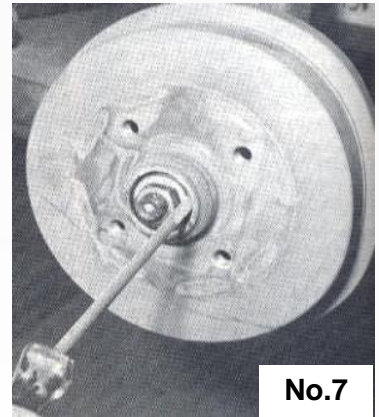

## Recommendations

Carefully follow all recommendations and use the correct methods of installation, make sure that all the new parts supplied in the kit such as bolts, nuts and washers are replaced along with the bearing.

Follow the vehicle manufacturer's installation procedures and apply the specified tightening torques.

Refer to the vehicle applications in our online catalogue: [e-shop](#)



Scan this QR code to access our online catalogue.

**FOLLOW THE RECOMMENDATIONS OF THE VEHICLE MANUFACTURER !**

©NTN-SNR ROULEMENTS

The contents of this document are the copyright of the publisher and any reproduction, even partial, is prohibited without permission.

Despite the care taken in preparing this document, NTN-SNR Roulements disclaims any liability for errors or omissions that may slip through, as well as for losses or direct or indirect damage arising from its use.

