



KD459.42/GB-07/2022

# KD459.42

## Assembly/disassembly recommendations

	<b>ENGINES</b>	<b>OE REFERENCE</b>
<p><b>CITROEN:</b> Berlingo (B9 et M59), C2, C3 (I, II et A51), C4, C5 (FI et X7), Dispatch II, Jumpy II, Xsara Picasso, C3 Picasso, C4 Picasso</p>	<p>1.6 TDCi, 1.6 D, 1.6 HDi, 1.6 DDiS, 1.6 d, 1.6 DE, 1.6 MZ-CD</p>	<p>1373306 1446648</p>
<p><b>FORD:</b> Fiesta (V, V FL, VI), Focus (C-MAX, II, II FL), Fusion ( I et FL), C-MAX (CB3)</p>		
<p><b>MAZDA:</b> Mazda 3 (3 et FL)</p>		
<p><b>MINI:</b> MINI 2, MINI Clubman</p>		
<p><b>PEUGEOT:</b> 206, 307, 307 Restyling, Expert II, Ranch, 407, Partner (B9 et M59), 1007, 207, 308, 3008, 5008</p>		
<p><b>SUZUKI:</b> SX4 et SX4 FL</p>		
<p><b>VOLVO:</b> S40, S80, V70, V50, C30</p>		

## TIMING KINEMATICS OF THE KIT KD459.42

### BELT WITH TEETH

**137 dents**

OE : 0818-G7, 1373250,  
Y6Y1-12-205,  
11 31 8 509 744,  
12761-69K01

### GT359.24(T)

OE : 0829-88, 1562503,  
Y401-12-720D,  
11 31 7 805 960,  
12810-73J01,  
31316844,  
SU001-00543

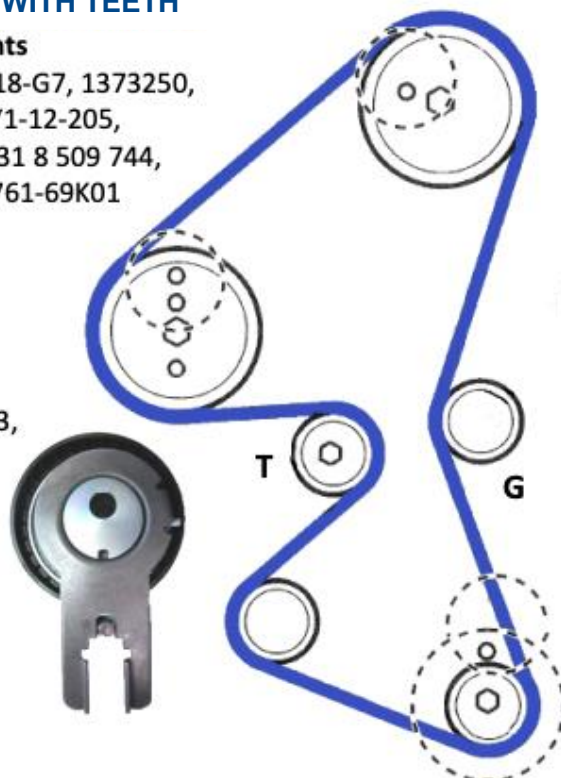

### GE359.23 (G)

OE : 0830-48, 1145955,  
11 31 7 805 961,  
12823-73J00, 30711069

## PROBLEMS WITH THE TENSIONER GT359.24

### PROBLÈME DE BRUIT AU ROULAGE

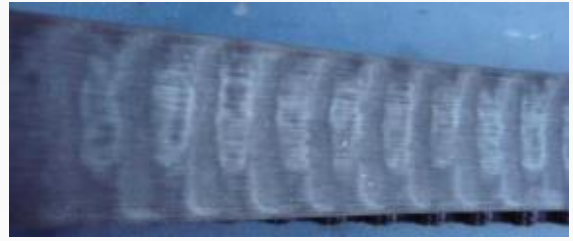

### PROBABLE CAUSE

#### An incorrectly fitted timing belt.

This fault is the sign of a timing belt operating with a lack of tension.

Here the belt slips on the rollers (hence wear observed on the back).

Operation is thus noisy, as the metal bracket of the tensioner comes into contact with the lower stop.



Under these conditions, the rise in the internal temperature of the roller can cause a grease leakage, which is nothing abnormal.

The bearing remains functional.

## REPLACEMENT

### Special tools:

- Camshaft sprocket locking tool - Peugeot No. AUT.0194-B
- Crankshaft alignment tool - Peugeot No. AUT.0194-A
- Flywheel locking tool - Peugeot No. AUT.0194-C
- High pressure fuel pump sprocket locking tool (Bosch pump) - Peugeot-A No. AUT.0194

### Precautions

- Disconnect the battery earth
- DO NOT turn the crankshaft or camshaft when timing belt has been fitted.
- Remove the spark plugs to facilitate the rotation of the motor.
- Rotate the engine in the normal direction of rotation (unless otherwise stated).
- DO NOT turn the engine with the camshaft or other drive gears.
- Adhere to tightening torques.

## REMOVAL

### 1) Raise the front of the vehicle

### 2) Remove:

- Front right wheel
- The right wheel fairing
- The timing belt

### 3) Install the flywheel locking tool (mark 1).

Tool No. AUT.0194-C. Make sure the flywheel is locked using the tool. Otherwise: Slowly turn the crankshaft clockwise.

### 4) Remove the wire harness from the upper timing case



### 5) Remove:

- Bolt for the crankshaft pulley (Mark 2)
- The crankshaft pulley (Mark 3)
- The flywheel locking tool (Mark 1)

### 6) Support the engine

### 7) Remove:

- The right-side engine mount and its bracke
- The lower timing cover (Mark 4)
- The upper timing cover (Mark 5)
- The timing belt guide (Mark 6)
- The crankshaft position sensor



Ensure that the target crankshaft is not damaged (Mark 7)

### 8) Fit the crankshaft pulley bolt (Mark 2)

### 9) Slowly turn the crankshaft clockwise

until the camshaft sprocket timing hole is at the 10 o'clock position (Mark 8)

### 10) Use the camshaft sprocket locking tool (Mark 9)

Tool no. (-).0194-B

### 11) Insert the crankshaft alignment tool (Mark 10)

Tool no. (-).0194-A

### 12) Use the high pressure fuel pump sprocket locking tool (Mark 11)

Tool no. (-).0194-A 1 (Bosch pump)

### 13) Loosen the roller tensioner bolt (Mark 12)

### 14) Turn the roller tensioner clockwise

to loosen off the belt. Use an Allen key (Mark 13)

### 15) Remove the timing belt

## REPLACING

### 1) Install the roller tensioner and pulley

2) Ensure the camshaft sprocket locking tool is correctly positioned (Mark 9).

3) Ensure the crankshaft alignment tool is correctly positioned (Mark 10).

4) Ensure that the high pressure fuel pump sprocket locking tool is correctly positioned (Mark 11).



**5) Place the timing belt in the following order**

- Crankshaft sprocket
- Fixed roller -> G (GE359.23)
- Camshaft sprocket
- High pressure injection pump sprocket
- Water pump sprocket
- Roller tensioner still pinned -> T (GT359.24)

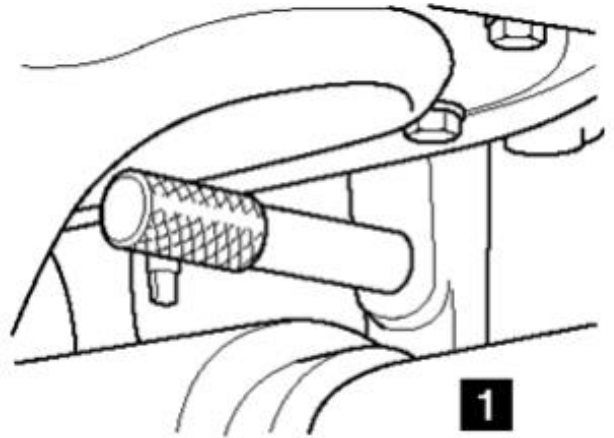

**6) Replace:**

- The timing belt guide (Mark 6)
- The crankshaft position sensor

**7) Loosen the roller tensioner bolt (Mark 12)**

**8) Turn the roller tensioner counter-clockwise until the cursor is aligned with the light (Mark 14). Use an Allen key (Mark 13)**

**9) Tighten the roller tensioner bolt (Mark 12)**

Tightening torque: 25 Nm

**10) Remove the pin of the roller tensioner**

**11) Remove:**

- Camshaft sprocket locking tool (Mark 9)
- The crankshaft alignment tool (Mark 10)
- The high pressure fuel pump sprocket locking tool (Mark 11)

**12) Turn the crankshaft six full turns clockwise**

**13) Insert:**

- Camshaft sprocket locking tool (Mark 9)
- The crankshaft alignment tool (Mark 10)
- The high pressure fuel pump sprocket locking tool (Mark 11)

**14) Ensure the roller tensioner cursor is aligned in the light mark 14.**

Otherwise: Repeat the installation procedure

**15) Remove:**

- Camshaft sprocket locking tool (Mark 9)
- The crankshaft alignment tool (Mark 10)
- The high pressure fuel pump sprocket locking tool (Mark 11)

**16) Install:**

- The upper timing cover (Mark 5)
- The lower timing cover (Mark 4)
- The crankshaft pulley (Mark 3)
- Bolt for the crankshaft pulley (Mark 2) - Tightening torque: 27-33 Nm + 180°

**17) Remove the flywheel locking tool (Mark 1).**

**18) Reinstall the remaining parts in the reverse order of removal**

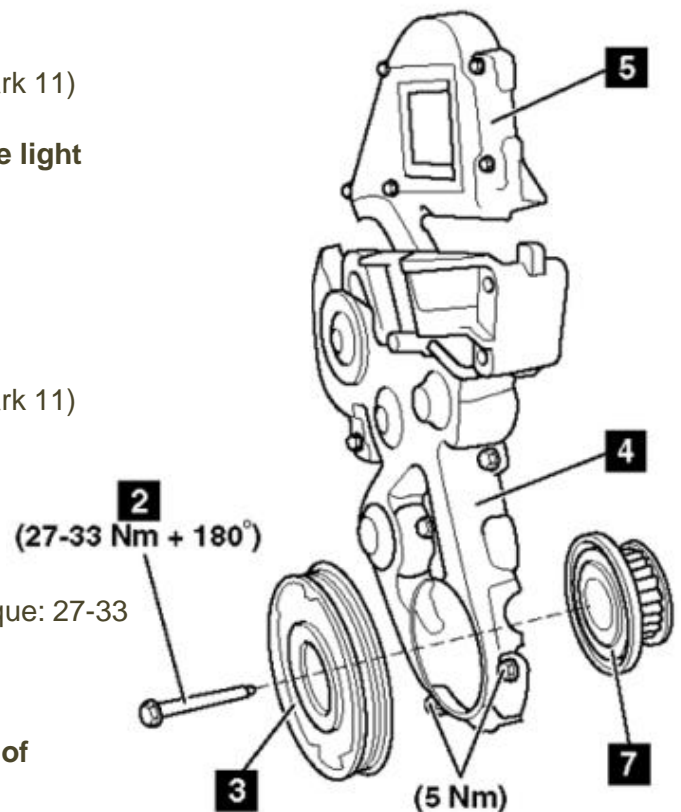
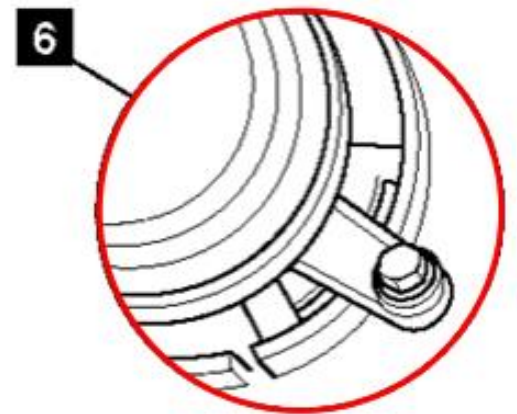

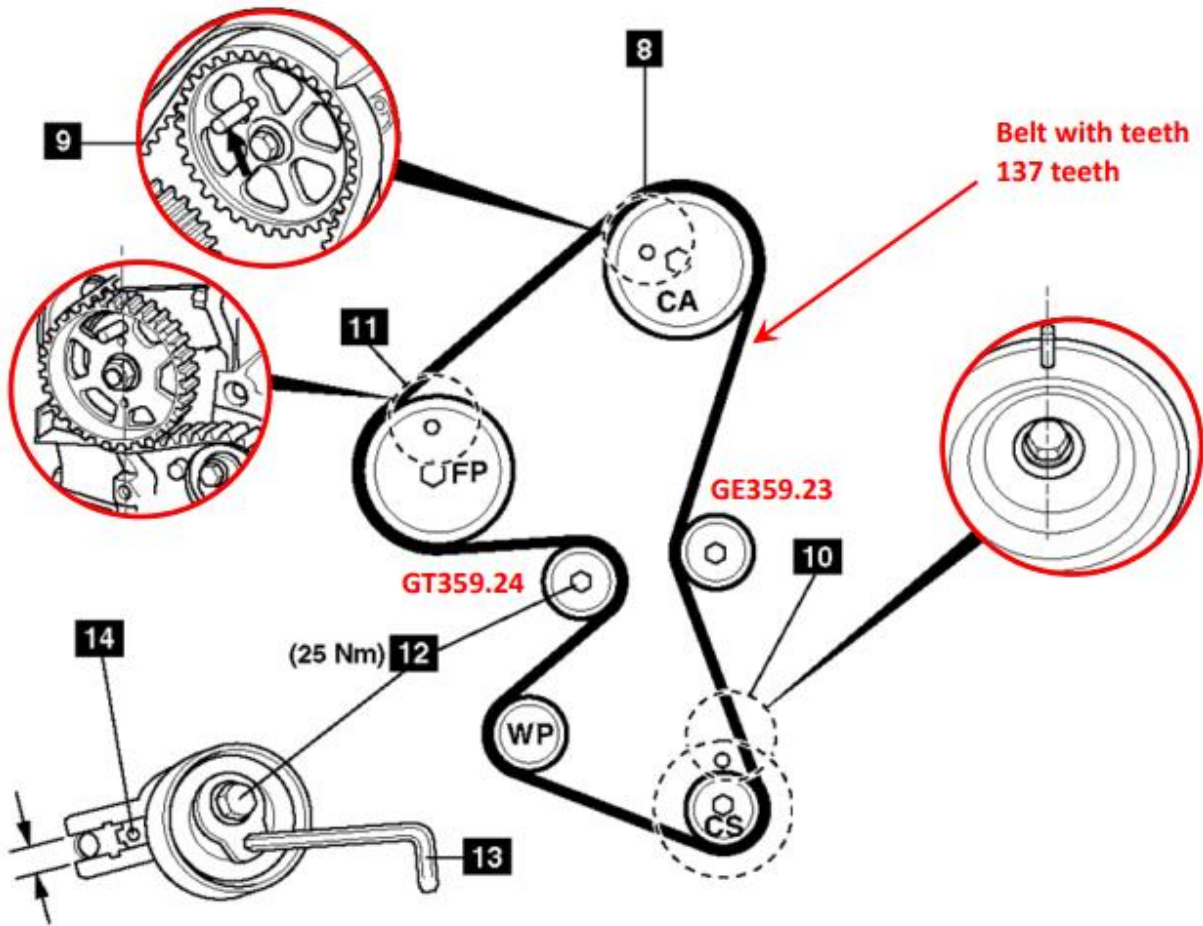

## Recommendations

Be sure pay attention to the tension setting system, which is counterclockwise.

Be sure to remove the pin of the roller tensioner once it was tightened.

Follow the manufacturers' assembly procedures as well as their indicated tightening torques.

Consult vehicle applications in our online catalogue: [eshop](#)



Use this QR Code to find  
our online catalogue

**ALWAYS FOLLOW THE VEHICLE  
MANUFACTURER'S RECOMMENDATIONS!**

©NTN-SNR Roulements

Le contenu de ce document est soumis au copyright de l'éditeur et de sa reproduction, même partielle, est interdite sans autorisation. Malgré le soin apporté à la réalisation de ce document, NTN-SNR Roulements décline toutes responsabilités pour les erreurs ou omissions qui auraient pu se glisser et pour les pertes ou dommages directs ou indirects découlant de son utilisation.

