



Addition to KD459.68 / KDP459.680 - UK/01 - 04/2023

When fitting a new timing belt kit on the 2.0 BlueHdi DW10F type engine, it is necessary to check the correct setting of the high-pressure fuel pump if the cylinder head has been removed. The pump used on this engine is a synchronous single-piston type pump which is able to reach a pressure of up to 2000 bars depending on the engine type. The pump is driven by the exhaust camshaft via a 1:2 ratio gear cassette so that the pump rotates at the same speed as the crankshaft.

The pump must be positioned angularly in relation to the crankshaft before any dismantling of the pump is undertaken. It is necessary to turn and lock the engine in a precise position. Incorrect fitment of this kit can result in premature failure of the belt. **The correct removal/refitment process is listed below.**

Effected engines are the 2.0BlueHdi (DW10F 130, 150, 180ch)

Incorrectly setting the HP pump on 2.0 HDi will not change the common rail pressure, but it must still be set correctly. The pump has an internal design which makes it possible to distribute the load on the timing belt evenly. The design means the forces within the pump act in opposition and therefore are never simultaneous taking load pressure, this means a uniform force is applied to the timing belt.

A correctly set pump optimizes the life of the timing belt, if the pump is incorrectly set it, reduces the life of the belt very quickly. An enormous amount of pressure is placed on the belt when the pump reaches the high-pressure point of its cycle. The belt is not designed to take the high forces generated; this leads to the belt failing.

WARNING: Do not remove the high-pressure fuel pump without having locked the camshaft pulley in the "high pressure fuel pump" position:

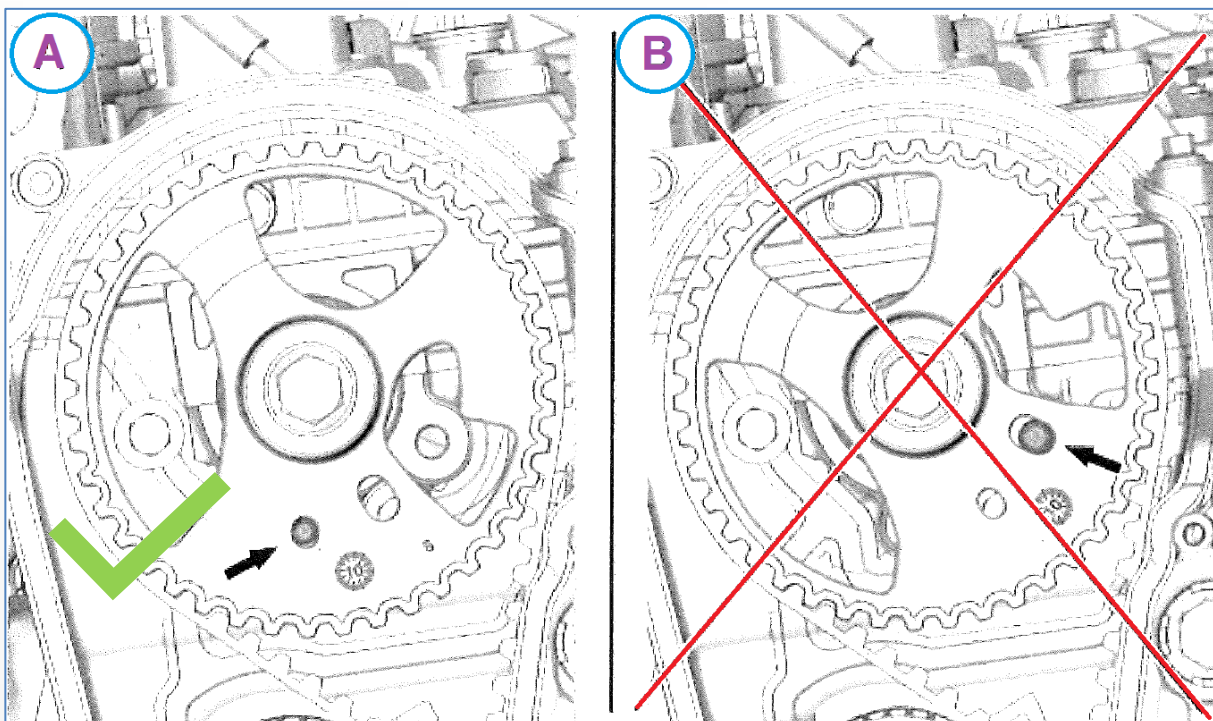

A High pressure fuel pump locking position (Ø 6mm)

B Timing position (Ø 8mm) **Do no use.**

The forces act in opposition and therefore are never simultaneous, generating an almost uniform force on the timing belt.

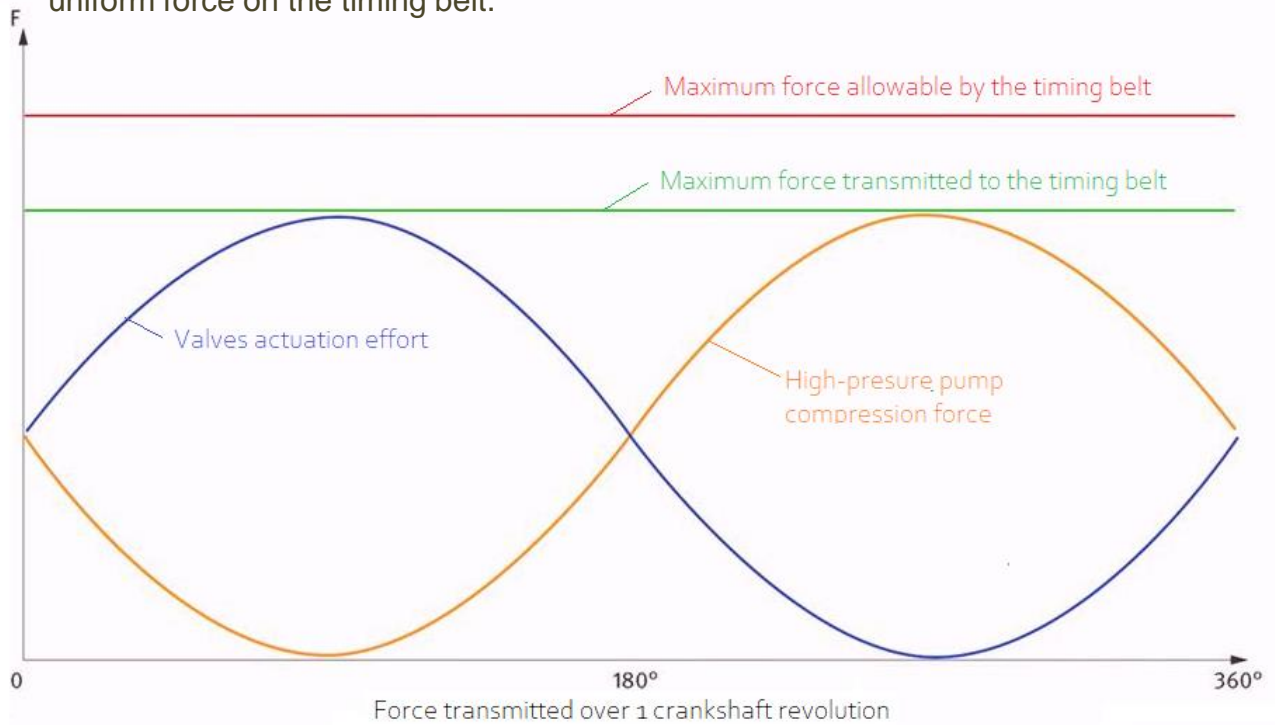

In the event of poor positioning, the forces transmitted to the belt either partially or completely, cause a large force on the timing this normally leads to the belt failing. The more the two forces add up, the sooner the belt will fail.

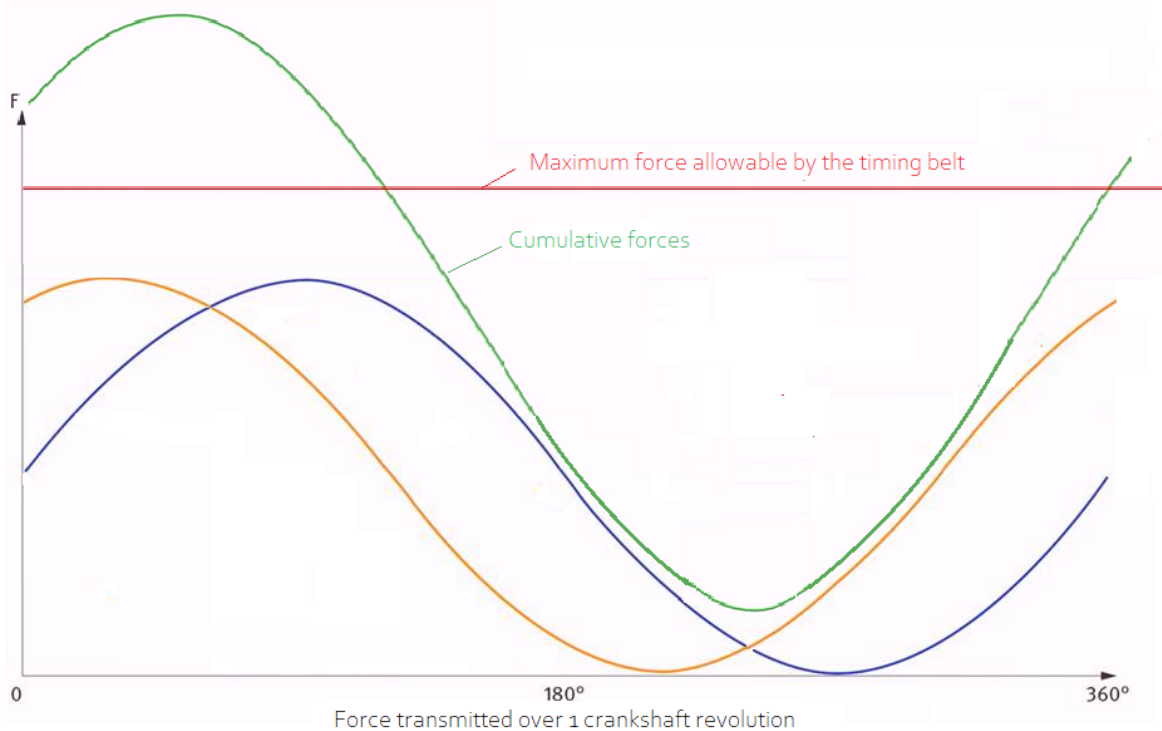

Vehicles		Engine	Type
Peugeot	308 (T9)	2.0 BlueHDi 180 FAP	DW10FC
		2.0 BlueHDi 150 FAP	DW10FD
	5008 (T87)	2.0 BlueHDi 150 FAP	DW10FD
		2.0 BlueHDi 135 FAP	DW10FD (100kW)
	3008 (T84)	2.0 BlueHDi 150 FAP	DW10FD
		2.0 BlueHDi 135 FAP	DW10FD (100kW)
	508	2.0 BlueHDi 180 FAP	DW10FC
	Boxer 3	2.0 BlueHDi 110 FAP	DW10FUE
		2.0 BlueHDi 130 FAP	DW10FUD
		2.0 BlueHDi 163 FAP	DW10FUC
	Traveller (K0)	2.0 BlueHDi 120 FAP	DW10FE
		2.0 BlueHDi 150 FAP	DW10FD
		2.0 BlueHDi 180 FAP	DW10FC
	Expert	2.0 BlueHDi 120 FAP	DW10FE
2.0 BlueHDi 150 FAP		DW10FD	
2.0 BlueHDi 180 FAP		DW10FC	
Citroën	SpaceTourer	2.0 BlueHDi 120 FAP	DW10FE
		2.0 BlueHDi 150 FAP	DW10FD
		2.0 BlueHDi 180 FAP	DW10FC
	Jumpy	2.0 BlueHDi 120 FAP	DW10FE
		2.0 BlueHDi 150 FAP	DW10FD
		2.0 BlueHDi 180 FAP	DW10FC
	C4 II	2.0 BlueHDi 150 FAP	DW10FD
	C4 Picasso	2.0 BlueHDi 150 FAP	DW10FD
	C4 GrandPicasso	2.0 BlueHDi 150 FAP	DW10FD
	C5	2.0 BlueHDi 150 FAP	DW10FD
		2.0 BlueHDi 180 FAP	DW10FC
	DS4	2.0 BlueHDi 150 FAP	DW10FD
		2.0 BlueHDi 180 FAP	DW10FC
	DS5	2.0 BlueHDi 150 FAP	DW10FD
2.0 BlueHDi 180 FAP		DW10FC	
DS 7 Crossback	2.0 BlueHDi 180 FAP	DW10FC	
Toyota	ProAce II	2.0 D-4D 150	DW10FD
		2.0 D-4D 180	DW10FC
Ford	Galaxy	2.0 TDCi 150	DW10FD
		2.0 TDCi 180	DW10FC
	S-Max	2.0 TDCi 150	DW10FD
		2.0 TDCi 180	DW10FC
Opel	Zafira Vie	2.0 D 120	DW10FE
		2.0 D 150	DW10FD
		2.0 D 180	DW10FC
	Vivaro C	2.0 D 120	DW10FE
		2.0 D 150	DW10FD
		2.0 D 180	DW10FC
Grandland X	2.0 Turbo D 180	DW10FC	



Replacement of parts

PARTS	QTY
Fuel high pressure pipe	1
Fuel return pipe from diesel injectors	1
Gaskets	1
Timing cover bolts	3

Tools required

- ✓ Leak detector
- ✓ Trolley jack
- ✓ Soft wedge
- ✓ Stud M8x125 length 50mm

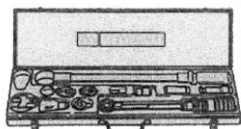

Locking tools [1603-ZZ]

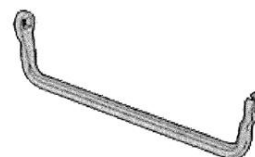

Diesel Injector union wrench [4704-T]



Hdi Plug set [1617-J]

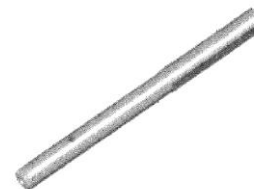

Locking pin [0188-H] / [EN-52335]



Gasket mounting cone
[1621-D] / [EN-52339-D]

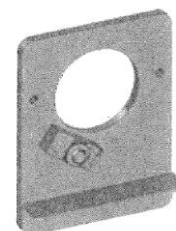

High pressure pump support
[1621-C] / [EN-52339-C]

Injection pump sprocket puller
[G-1621-C3]

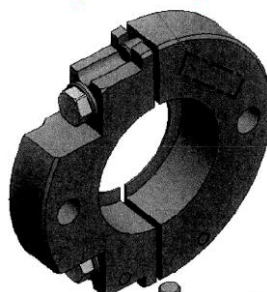

Removal

Raise the vehicle on a trolley jack

Remove, the engine covers

CAUTION: Carry out these jobs before disconnecting the battery.

Disconnect the battery

Remove.

- ✓ Battery
- ✓ The engine computer (ECU)
- ✓ The front right wheel.
- ✓ The right front fender guard
- ✓ Engine covers
- ✓ The accessorie belt cover
- ✓ The upper right anti-torque rod
- ✓ The low-pressure fuel pipe

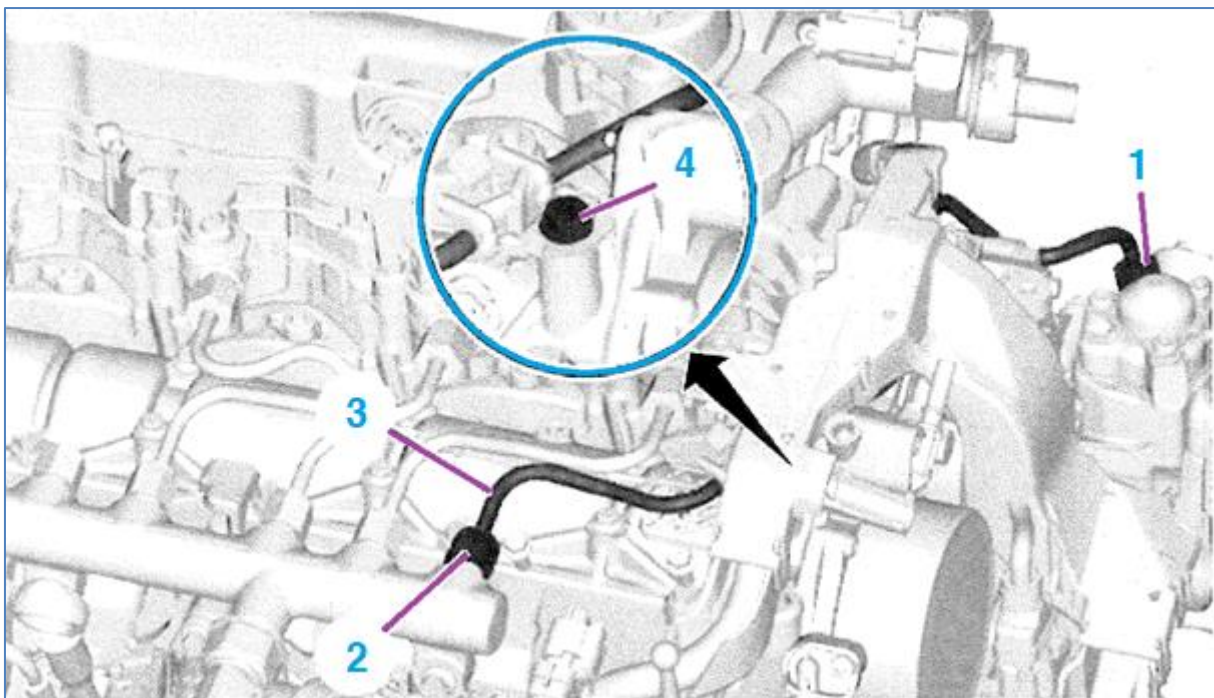

CAUTION: Clean the high-pressure connections before loosening.

WARNING: Immediately seal the fuel connections using the plugs [1617-J].

Remove, the bolt (4).

Unscrew

- ✓ Connection (1) high-pressure fuel pipe (3)
- ✓ Connection (2) high-pressure fuel pipe (3)

Remove the high pressure fuel pipe (3).



The low-pressure fuel pipe channel on the upper timing cover.

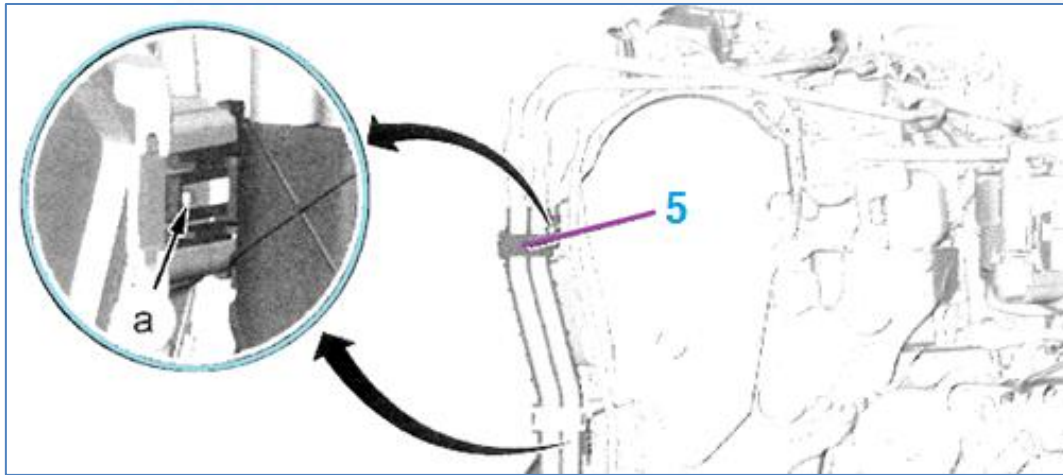

Unclip the clamp (5) on the low-pressure fuel pipes, from the upper timing cover (at "a").
Continue the removal:

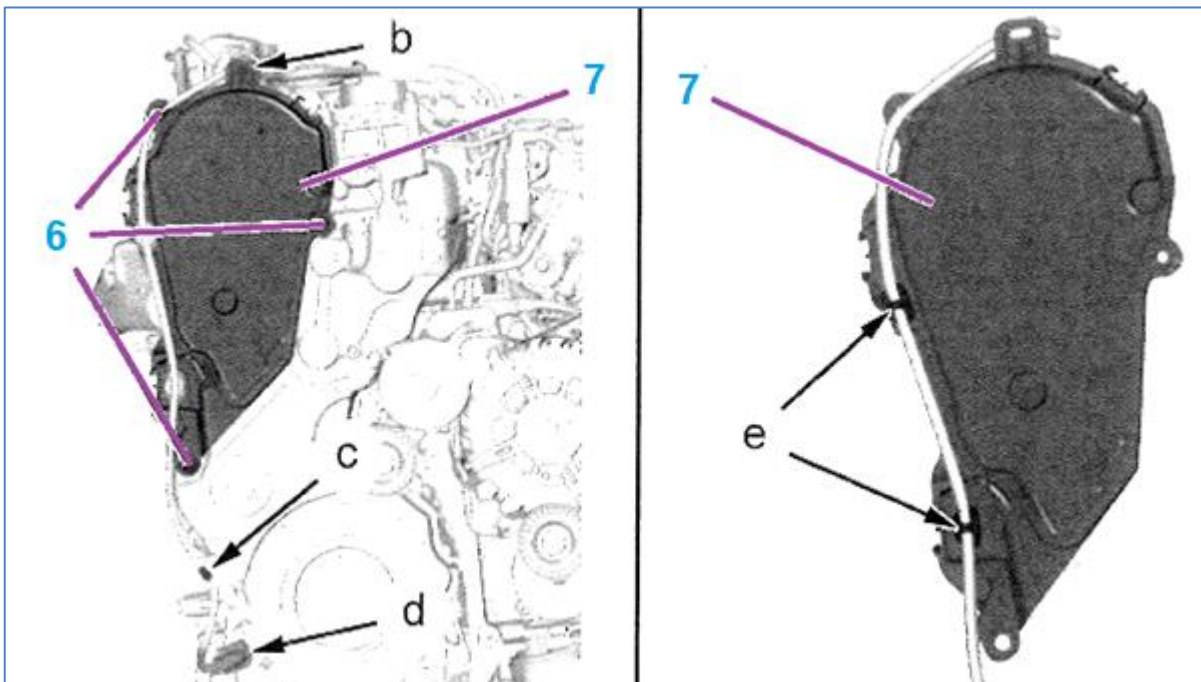

Unclip the low-pressure fuel pipes from the upper timing cover (7).

Disconnect the engine speed sensor connector (at "d").

Unclip the electrical harness (at "b", "c").

Remove the screws (6).

Remove the upper timing cover (7).

Unclip the electrical harness (at "e").

To file:

- ✓ The upper timing cover (7)
- ✓ The crankshaft pulley cover



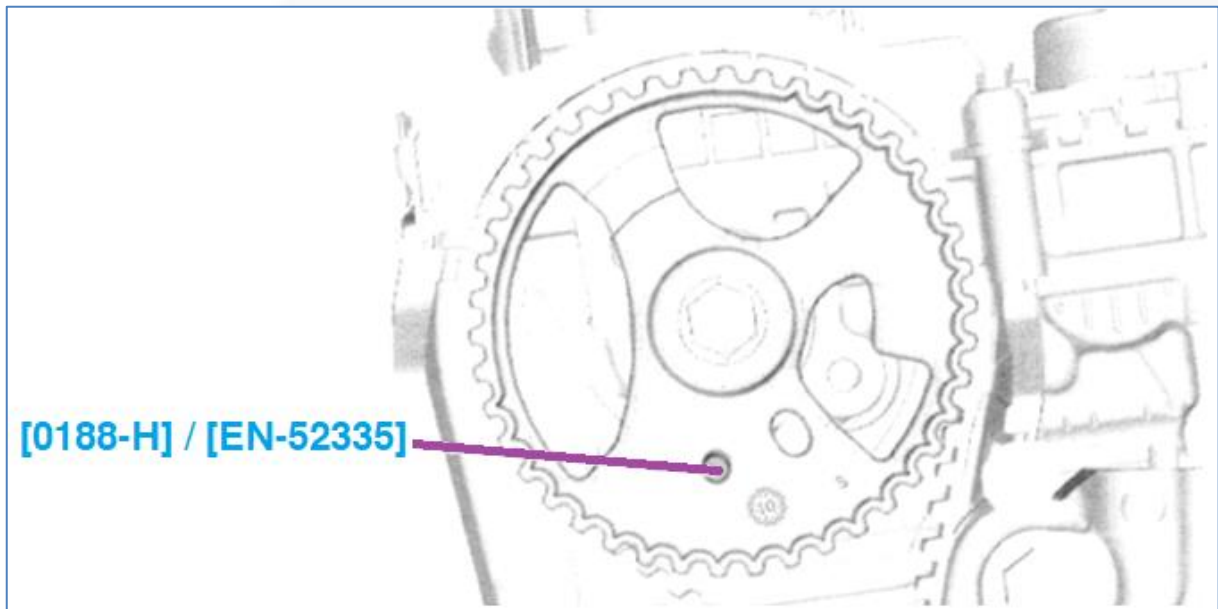

Turn the engine using the crankshaft pulley bolt until the camshaft pulley is in the “high-pressure fuel pump” setting position “A”

Lock the camshaft pulley using the locking tool [0188-H / EN-52335].

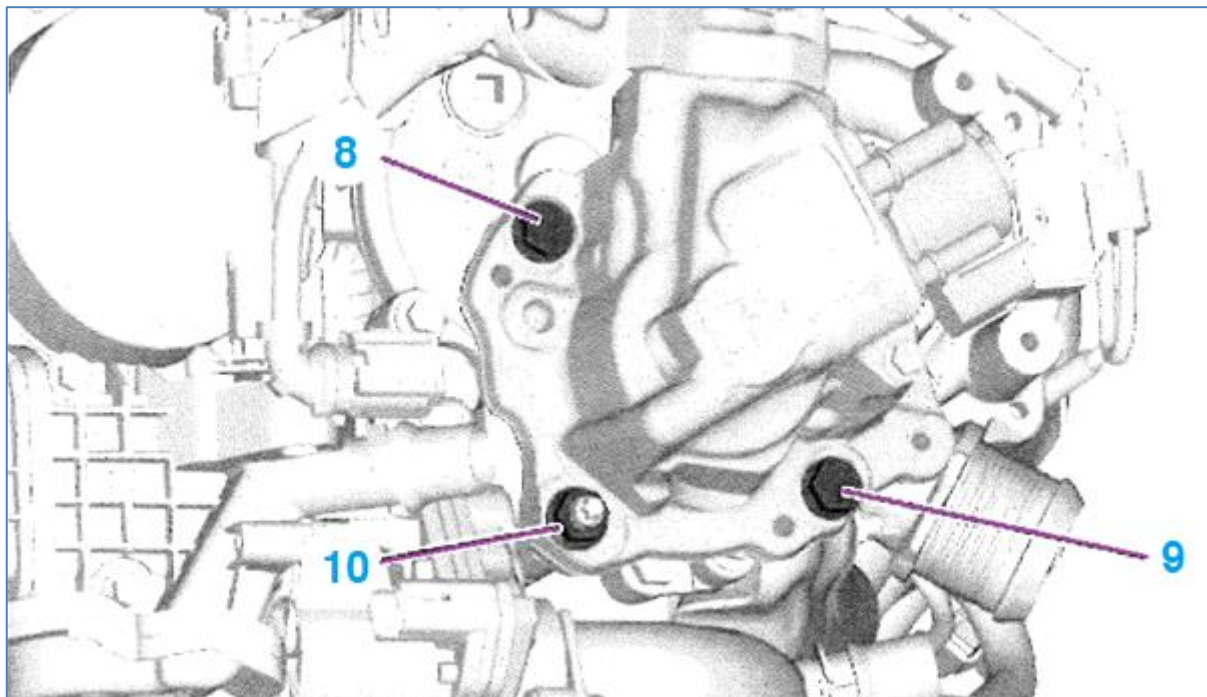

Remove:

- ✓ Bolts (8), (9)
- ✓ Nut (10)



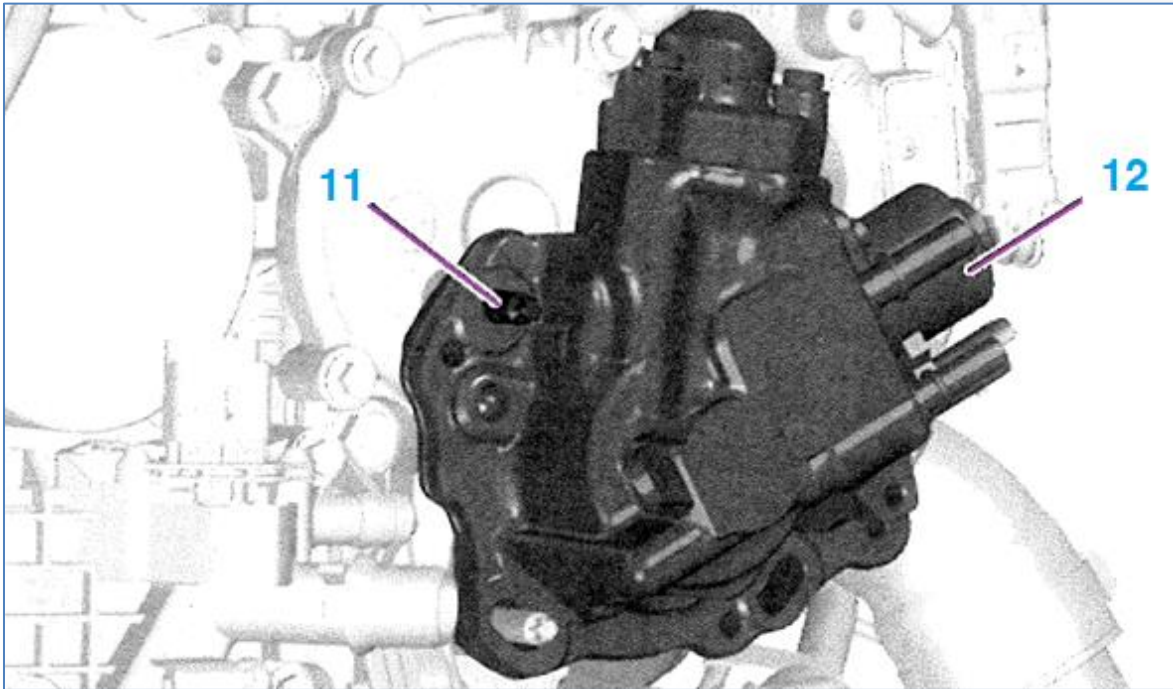

WARNING: Remove the high-pressure fuel pump (12) without rotating it.

Replace the bolt (8) with the M8x125 stud (11).

Slightly move aside the high-pressure fuel pump (12) using a flat blade screwdriver if necessary.

Unclip the high-pressure fuel pump cooling circuit pipe (12) (depending on the model).

Remove the high-pressure fuel pump (12).

CAUTION: Clean the joint surface with a degreasing product

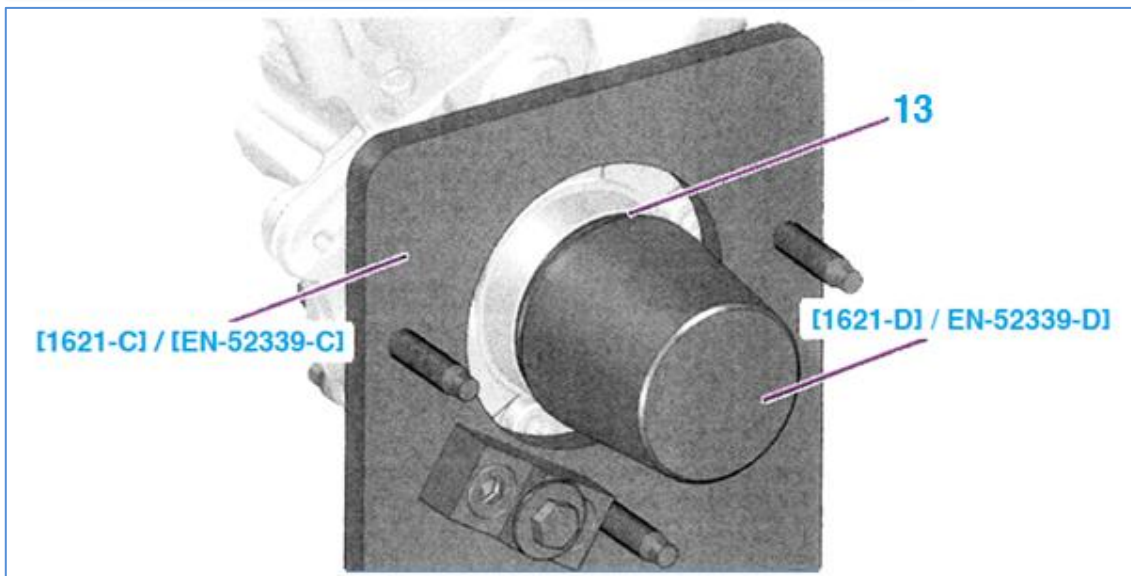

Position the high-pressure fuel pump (12) on the support [1621-C / EN-52339-C]

WARNING: Do not use abrasive or sharp tools on the mating surfaces.

Lubricate and refit the new seal (13) using tool [1621-D / EN-52339-D] .

Remove the high-pressure fuel pump (12) on the support [1621-C / EN-52339-C]



Reassembly

WARNING: Follow all the tightening torques

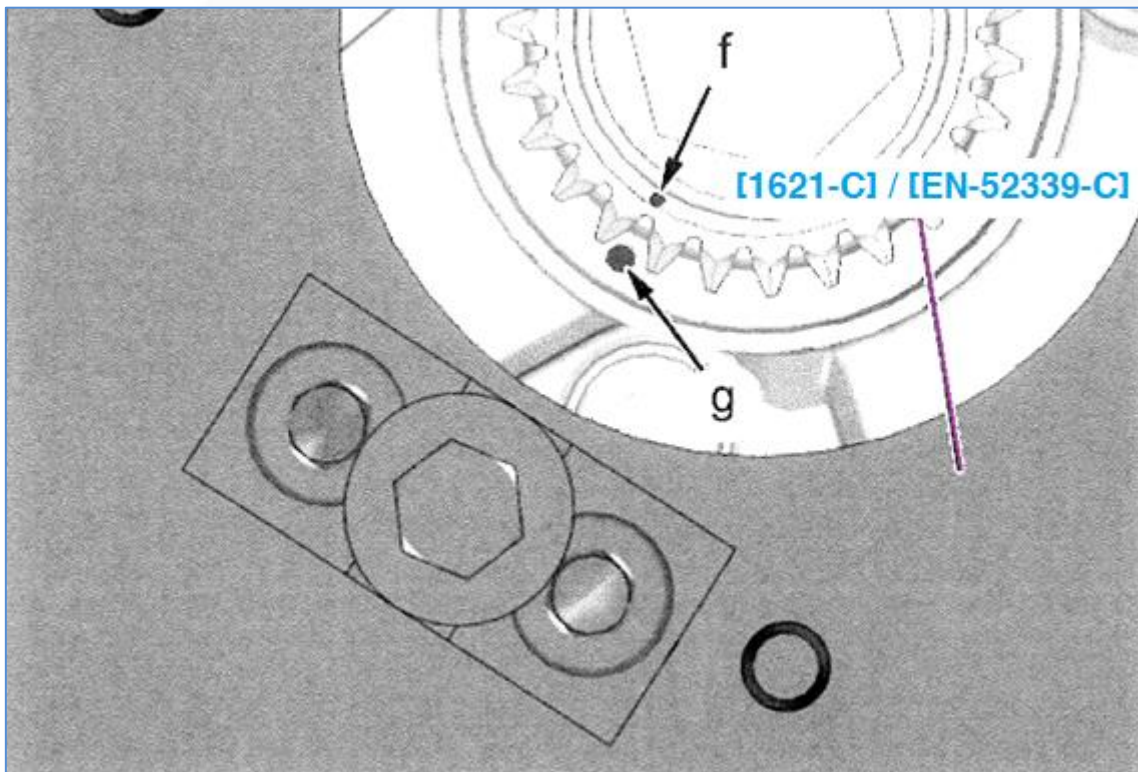

Check the alignment of the marks "f", "g".

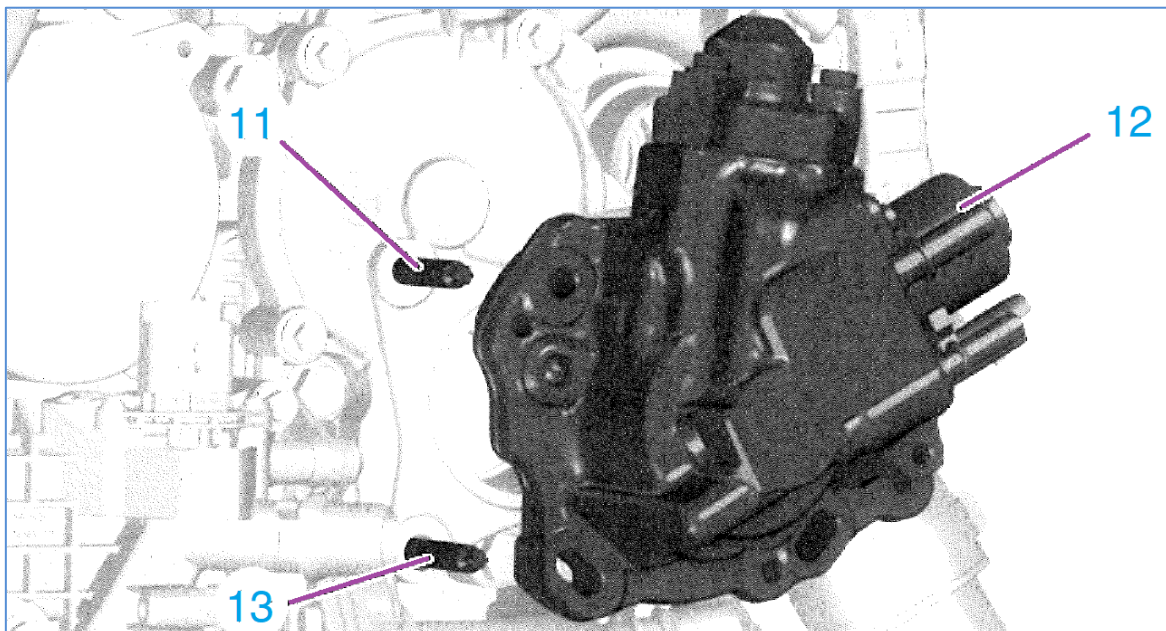

WARNING: An incorrect refitting of the high-pressure fuel pump (12) can lead to an offset of the "f", "g" marks. This causes a risk of timing belt failure.

CAUTION: The M8x125 stud must be fitted.

Refit the high-pressure fuel pump (12) on the studs (11), (13) to guide it into its housing



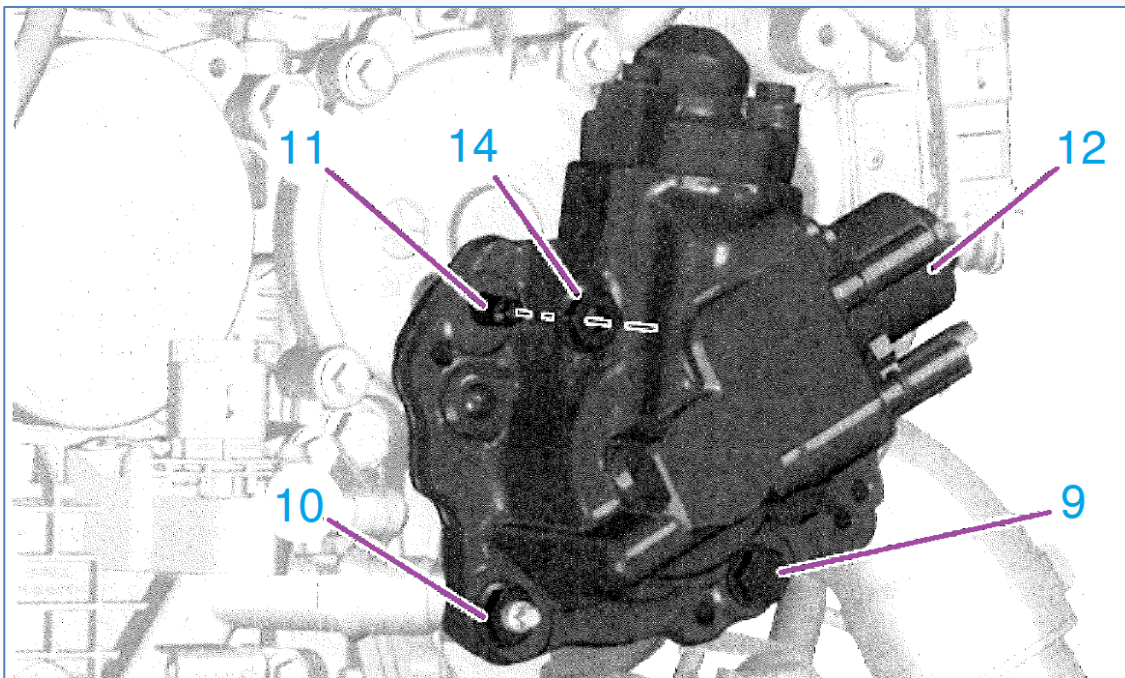

Refit:

- ✓ Nut (14) on the stud (11)
- ✓ Bolt (9)
- ✓ Nut (10)

Tighten fixings (9), (10), (14) to press the high-pressure fuel pump (12) against its support.

Remove:

- ✓ Nut (14)
- ✓ Stud (11)

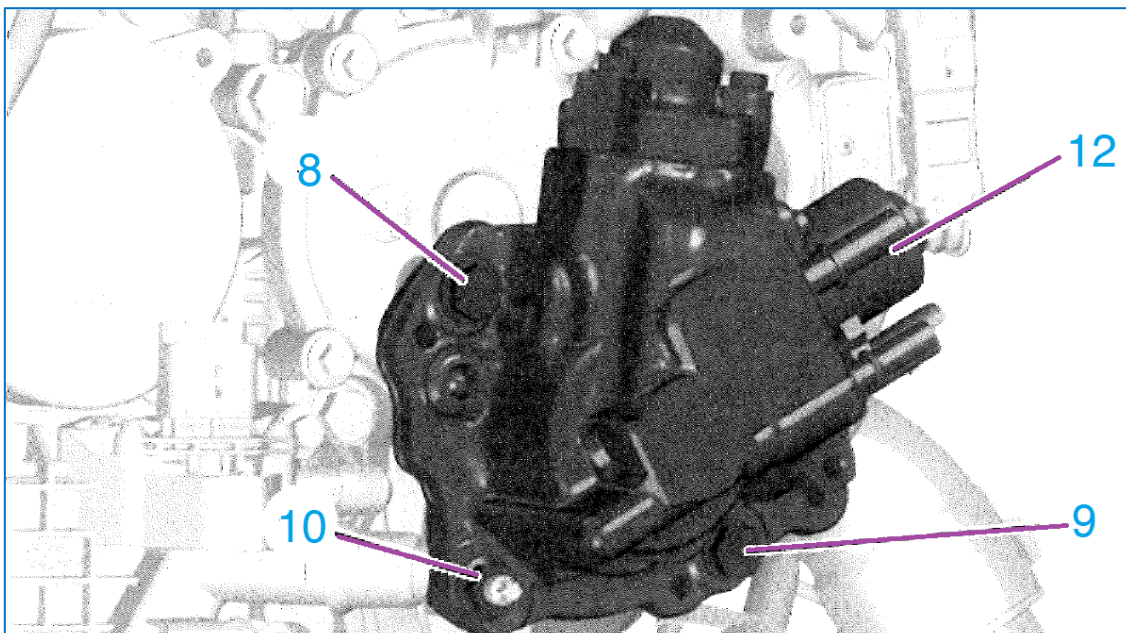

Refit bolt (8).

Tighten to torque:

- ✓ Bolts (8), (9)
- ✓ Nut (10)



Clip the engine cooling circuit pipe to the high-pressure fuel pump (12) (depending of model).
Remove the locking tool [0188-H / EN-52335] from the camshaft pulley.
Refit the crankshaft pulley cover, using rubber lubricant if necessary.

CAUTION: Check the retention of the crankshaft pulley cover by pulling it moderately.

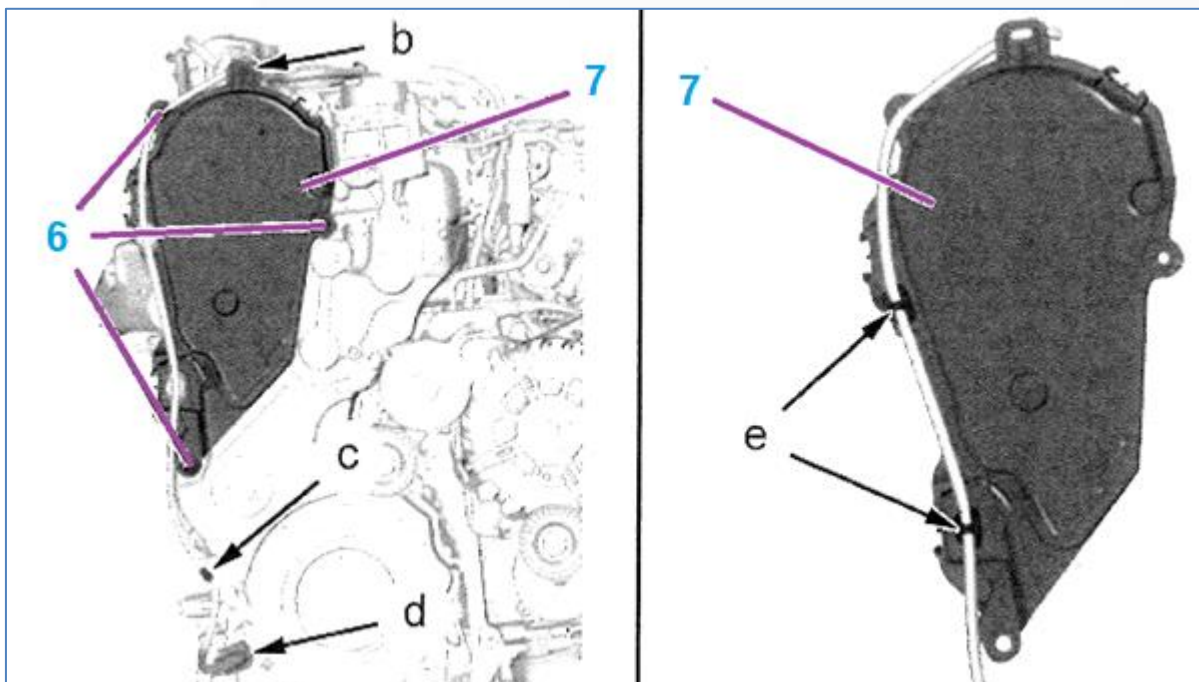

Clip the electrical harness (at "e").

Refit:

✓ Upper timing cover (7)

✓ Bolts (6)

Clip the electrical harness (at "b", "c").

Reconnect the engine speed sensor connector (at "d")

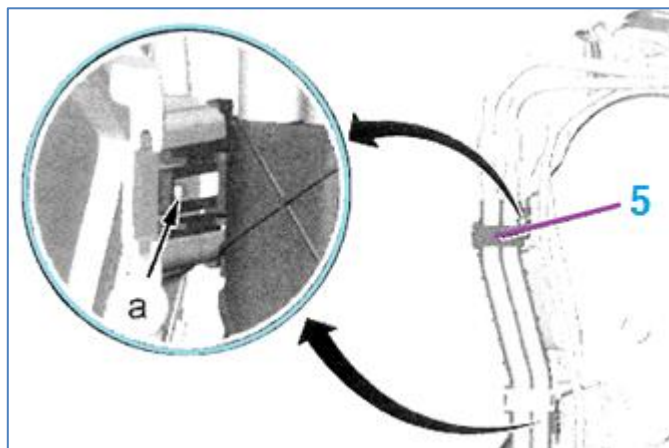

Clip the low-pressure fuel pipe channel (5) back onto the upper timing cover (at "a") (depending on model).



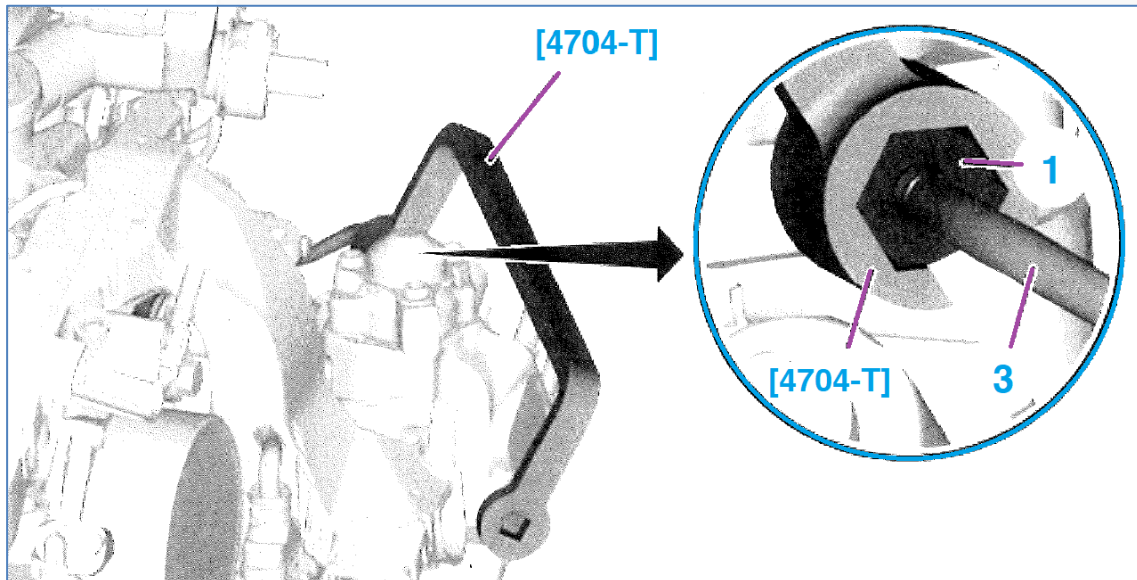

Refit the fuel high-pressure pipe (3) (New).

NOTE: Use tool [4704-T] on the union (1)

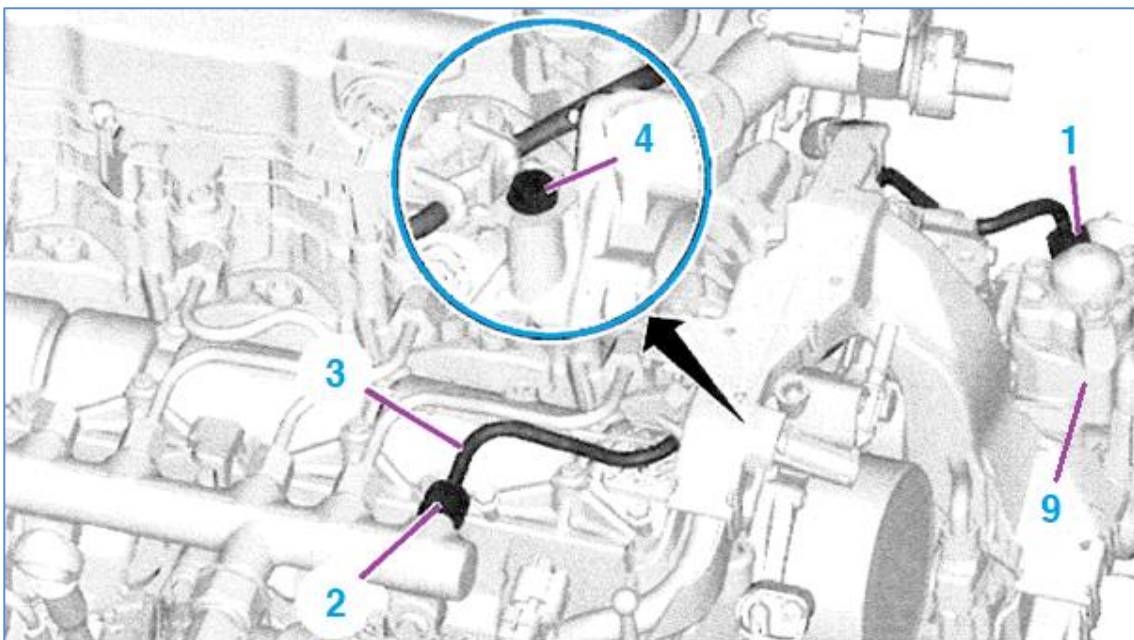

Tightening the connections using the [4704-T], [1603-ZZ]:

- ✓ Tighten the unions (1), (2) of the fuel high-pressure pipe (3) (by hand)
- ✓ Tighten the screw (4) (by hand)
- ✓ Pre-tighten the union (1) on the high-pressure fuel pipe (3) on the high-pressure fuel pump (9)
- ✓ Pre-tighten the union (2) on the fuel high-pressure pipe (3) on the fuel high-pressure common rail
- ✓ Tighten the union (1) on the high-pressure fuel pipe (3) on the high-pressure fuel pump (9)
- ✓ Tighten the union (2) of the fuel high pressure pipe (3) on the fuel high-pressure common rail
- ✓ Tighten the bolt (4)



Refit:

- ✓ The low-pressure fuel pipe support
- ✓ The upper right anti-torque rod
- ✓ The accessory belt cover (depending on model)
- ✓ The right front fender guard
- ✓ The right front wheel
- ✓ Engine covers
- ✓ The engine computer (ECU)
- ✓ The Battery

CAUTION: Only re-fit the battery after the above jobs have been carried out.

Reconnect the battery

Prime the fuel circuit by turning the ignition key to the ON position

Lower the vehicle back onto the ground

Final checks

Leak test:

- ✓ Spray leak detector product on the high-pressure fuel unions (1), (2)
- ✓ Let the product dry
- ✓ Start the engine
- ✓ Check for leaks
- ✓ Take a test drive
- ✓ Check for leaks
- ✓ Replace defective parts (if necessary)

NOTE: Use a plug-in diagnostic tool, to check for any fault logs

