

# Independent Powerful Precise

Especially adapted for your **markets**

- Cement
- Steel
- Mining
- Quarrying

Perfect for your **applications**



Electric motors

Conveyors



Pumps

Fans



More information on our range.

Distributed by:

This document is the exclusive property of NTN-SNR ROULEMENTS. Any total or partial reproduction hereof without the prior consent of NTN-SNR ROULEMENTS is strictly prohibited. Legal action may be brought against anyone breaching the terms of this paragraph.

NTN-SNR ROULEMENTS shall not be held liable for any errors or omissions that may have crept into this document despite the care taken in drafting it. Due to our policy of continuous research and development, we reserve the right to make changes without notice to all or part of the products and specifications mentioned in this document.

© NTN-SNR ROULEMENTS, international copyright 2016



[www.ntn-snr.com](http://www.ntn-snr.com)



With You

NTN-SNR ROULEMENTS - 1 rue des Usines - 74000 Anancy  
RCS ANNECY B 325 821 072 - Code APE 2815Z - Code NACE 28.15  
[www.ntn-snr.com](http://www.ntn-snr.com)

DOC\_L\_DRIVEBOOST\_ARG2.GBA - SAP: 360 533 - NTN-SNR Copyright International 12/2015 - Conception : NTN-SNR - Photos : Pedro Studio Photo - X



## NEW DRIVE BOOSTER

a new generation of  
electromechanical  
single Point lubricator  
system



[www.ntn-snr.com](http://www.ntn-snr.com)



With You

## Technical information

- Reusable electromechanical drive
- Easy-to-use refill cartridges
- All around LED lights (red/green)
- Transparent cartridge
- Immediate discharge

Changeable and stoppable system  
 Discharge period from 1 to 12 months  
 Powerful Alkaline battery pack  
 Capacity of 120 & 250 cm<sup>3</sup>  
 Max. pressure build-up 6 bars  
 IP65 protection class  
 Ambient temperatures: from -10°C up to +60°C

Dimensions      Refill 120: Ø75 x 178 mm  
 Refill 250: Ø75 x 228 mm

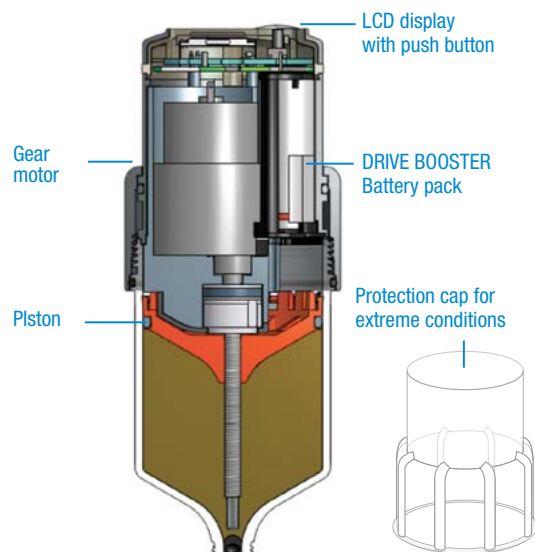

## DRIVE BOOSTER 120 & 250

### Benefits

- **Easy set up:** multifunction LCD Display with single push button and flexible settings (1-12 months, changeable and stoppable at any time)
- **Powerful & operational in dusty remote areas:** 6 bar pressure allows remote mounting with tubes up to 5 meters - IP65
- **Quick visual control:** Electromechanical reusable drive unit with coloured LED signals for operating status

> FOR YOUR APPLICATION,  
 SELECT THE MOST SUITABLE GREASE  
 FOR YOUR AUTOMATIC LUBRICATOR



	UNIVERSAL +	HEAVY DUTY +	VIB	HIGH TEMP	FOOD
<b>DESCRIPTION</b>	General purpose grease for industrial use	Suitable for very high loads, compatible with many applications, intended for arduous applications	Parts subject to extensive vibration or impacts. For high-load applications in humid environments	This grease is ideal for long-term lubrication at high temperatures up to 150°C, Accepts peaks of +175°C	Multi-purpose grease for the food and pharmaceutical industries. Complies with NSF-H1 recommendations
<b>APPLICATIONS</b>	Agricultural equipment, handling equipment, general mechanical devices, low-power electric motors, etc.	Heavy industry: metallurgy, construction, transport, conveyors, lifting devices, water pumps, etc.	Quarries, cement plants, public works and humid environments: paper works, boring, crushers, vibrating scalpels, etc.	Textile machines, paper transformation machines, hot fans, dryers, water pumps, etc.	Bottling machines, dairy equipment, industrial baking, pasta manufacturing, confectionery, slaughterhouses, etc.
<b>TECHNICAL DATA</b>					
Soap	Lithium Calcium	Lithium	Lithium Calcium	Polyurea	Aluminium complex
Oil	Mineral	Mineral	Semi-Synthetic	Semi-Synthetic	Mineral
Operating temperature	-30°C/+130°C	-30°C/+150°C	-20°C/+140°C	-40°C/+160°C	-30°C/+120°C
Viscosity at 40°C	220 cSt	150 cSt	360 cSt	160 cSt	195 cSt
Product name	Luber DRIVE Universal+	Luber DRIVE Heavy Duty+	Luber DRIVE VIB	Luber DRIVE High Temp	Luber DRIVE Food