

IN'PULSE Oil Lubrication Electro-Pump

User and Maintenance Manual Warranty information

Manual drawn up in accordance with EC Directive 2006/42



***Pour obtenir ce manuel d'utilisation en français, veuillez consulter notre site Internet :
www.ntn-snr.com***

***Um unsere deutsche Gebrauchsanweisung zu erhalten, besuchen Sie uns auf unserer
Homepage: www.ntn-snr.com***

***Para conseguir este libro de instrucciones en español, consultar nuestro sitio Internet :
www.ntn-snr.com***

***Per ricevere questa guida utente in italiano, si prega di visitare il nostro sito Web:
www.ntn-snr.com***

1. TABLE OF CONTENTS

1. Table of contents	p.2	10. Maintenance procedure	p.15
2. Introduction	p.2	11. Disposal	p.15
3. General description	p.2	12. Dimensions	p.15
4. Product-machine identification	p.3	13. Handling and transportation	p.16
5. Technical specifications	p.3	14. Operating hazards	p.16
6. Machine components	p.4	15. Contraindications	p.16
7. Unpacking and installing the machine	p.6	16. Warranty information	p.17
8. Instructions for use	p.9	17. Declaration of conformity	p.18
9. Troubleshooting	p.14		

2. INTRODUCTION

This user and maintenance manual refers to the IN'PULSI lubrication system.

This manual should be conserved in such a way that it remains undamaged over time and is readily available to personnel needing to consult it.

The manufacturer reserves the right to update the product and/or the user and maintenance manual without the obligation to revise previous versions. Further copies of this manual, updates or clarifications can be obtained by directly contacting Experts & Tools at NTN-SNR Roulements, or to consult our web site at www.ntn-snr.com.

The use of the equipment referred to in this manual must be entrusted to qualified personnel with a basic knowledge of mechanics, hydraulics and electrical systems.

It is the responsibility of the installer to use tubing suitable for the system; the use of inadequate tubing can cause problems with the pump, injury to persons and create pollution.

Loosening of connections can cause serious safety problems; carry out a check before and after installation and, if necessary retighten them.

Never exceed the maximum working pressure values permitted for the panel and the components connected to it.

Before any maintenance or cleaning operation disconnect the power supply, close off the air supply and discharge the pressure from inside the equipment and the tubing connected to it.

Do not subject the panel, the connections, the tubing or parts under pressure to violent impacts; damaged tubing or connections are dangerous and should be immediately replaced.

After long periods of inactivity check air tightness of all parts subjected to pressure.

Personnel must use personal protection equipment, clothing and tools adequate for the location and the use of the panel both during its operation and during maintenance operations.

The panel, and any accessories mounted on it, should be carefully checked immediately on receipt and in the event of any discrepancy or complaint the NTN-SNR Roulements Sales department should be contacted without delay.

NTN-SNR Roulements declines to accept any responsibility for injuries to persons or damage to property in the event of the non-observance of the information presented in this manual.

Any modification to component parts of the system or the different destination of use of this system or its parts without prior written authorization from NTN-SNR Roulements will absolve the latter from any responsibility for injury to persons and/or damage to property and will release them from all obligations arising from the guarantee.

3. GENERAL DESCRIPTION

Oil lubrication pump IN'PULSE has been designed for industry machine tools. The electric gear pump is designed to work with LUBSO INJECT ou LUBSO MANIFOLD.

IN'PULSE is available in two versions:

- Manual IN'PULSE, manually controlled or via the PLC of the machine tool;
- Automatic IN'PULSE (or programmable), automatically controlled via a built-in controller.

3.1 LUBRICATION CONTROL SYSTEM - PRINCIPLES OF OPERATION

Automatic IN'PULSE operates on the principle of intermittent lubrication which involves the following three steps:

- Prelube
- Lube (lube – wait)
- Standby

3.1.1 Prelube

This step is made up of a set of cycles (max 999 cycles) during which the lubrication system runs a series of lubrication cycles (lubrication will be described in paragraph 3.1.2) necessary to vent air from the pump and check lubrication functions.

Prelube takes place:

- on POWER-ON;
- on RESET;
- Any time new parameters are set.

When prelube is set to "0", Intermittent Lubrication will only consist in the lube – standby/standby - lube phases (see START mode).

3.1.2 Lube

This step is made up of a set of cycles (max 999 cycles) during which lubrication is carried out. Each cycle consists of two sub-cycles (lube and wait) and involves the monitoring of timers and/or inputs:

- during lube, system delivers lubricant to the lubrication points;
- during wait, a timer defines the wait time between two lube cycles or before the beginning of the standby phase (in case only 1 lube cycle was set).

There are three types of lube:

- TIMER: Lubricant delivery is simply regulated by a timer;
- PS: Lubricant delivery is carried out only if the system is under pressure;

3.1.3 Standby

During this step lubrication system is idle until the next lubrication cycle. There are three ways to regulate standby:

- TIMER: a timer regulate system idling;
- PULSE: a pulse counter regulate system idling;
- BOTH: both a timer and a pulse counter regulate system idling. The type of standby will depend on which of these two events will start first.

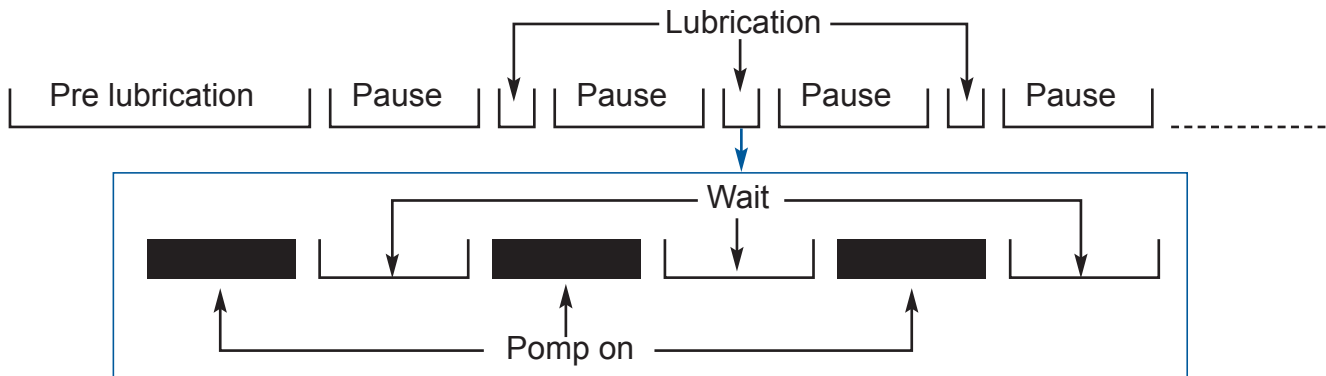

4. PRODUCT-MACHINE IDENTIFICATION

Machine identification yellow label is located on the side of the reservoir and contains product serial number, input voltage and details of the operating parameters.

5. TECHNICAL SPECIFICATIONS

5.1 GENERAL TECHNICAL SPECIFICATIONS

Lubricant	Minral Oil
Lubricant Viscosity at usage temperature	68 to 320 cSt (320 to 1480 SUS)
Working Temperature	+5°C to + 60°C (+41°F to +140°F)
Storage Temperature	- 20°C to + 60°C (-4°F to +140°F)
Working Humidity	90% max
Mechanical Protection Grade	IP-55
Sound Pressure Level	<70 dB (A)

5.2 ELECTRIC GEAR PUMP

Voltage	110V/50Hz	110V/60Hz	230V/50Hz	230V/60Hz
Power absorption	162W	155 W	150W	148W
Nominal current	1.48A		0.69A	0,70A
Pump flow rate	180 cm ³ /min (10.98 cu.in.)/min	220 cm ³ /min (13.42 cu.in.)/min	180 cm ³ /min (10.98 cu.in.)/min	220 cm ³ /min (13,45 cu.in.)/min
Maximum pressure	30 bars (411psi)			
Reservoir capacity	3 litres (0.66 gals)			
By-pass calibration	25 bars (367.5 psi)			
Pressure Switch calibration	18 bars (264.6 psi)			
Insulation Class	B			
Rotation direction	Clockwise			
Revolutions/min	2900	3500	2900	3500
Max continuous working time	2 minutes			
Min standby time	5 times MIN setup time			

NOTE: pump output is energized.

6. MACHINE COMPONENTS

The following main components are assembled to the baseplate:

- A reservoir, made of transparent plastic material;
- An electric gear pump, with high performance and minimum power consumption;
- A level sensor, which indicates lubricant minimum level via a N.O. electric contact (reservoir empty). To reverse N.O. to N.C., please contact NTN-SNR Experts & Tools Dept.;
- A pressure gauge;
- A N.O. pressure switch, which detects system under pressure;
- A printed circuit for user connections (see 7.4.2)

6.1 MANUAL IN’PULSE

The electronic board, located under the cover of manual IN’PULSE, allows pressure switch and electric level contact management both independent or serial.

On the front panel there are:

- Push-button for manual control, “MANUAL”
- LED indicator for “PUMP ON”. (Green, normally off)



6.2 AUTOMATIC IN’PULSE

The controller, located under the cover of automatic IN’PULSE, allows a total pump autonomy both in cycle times, alarms or checks.

On the front panel there are:

- LCD with 16 characters x 2 lines
- Push-buttons: three for control/management and one RESET button
- LED indicator for “POWER ON” (Green, always on)



7. UNPACKING AND INSTALLING THE MACHINE

7.1 UNPACKING

Once a suitable location has been found to install the unit, remove the pump from package. Check the unit has not been damaged during transportation or storage. No particular disposal procedures are necessary as package materials are no dangerous for health or environment. However, package should be disposed of in accordance with regulations that may be in force in your area or country.

7.2 INSTALLING THE PUMP

- In order to facilitate any maintenance intervention, to avoid unnatural posture for personnel during machine operation or the possibility of sustaining impacts, install the machine in a comfortable and easy-to-reach location.
- Allow sufficient space for the installation, leaving minimum 100 mm (3.9 in.) around the unit.
- Do not install the unit in aggressive or explosive/inflammable environments or on vibrating surfaces.
- To install the pump, use only the supplied bracket provided with two holes for $\varnothing 6$ mm ($\varnothing 0.2$ in.) screws (see Dimensions, ch. 12).

7.3 HYDRAULIC CONNECTION

Connect IN'PULSE to the system via the hydraulic connection located on the baseplate, on the right side of the pump: standard thread $\frac{1}{4}$ BSP.

7.4 ELECTRIC WIRING

7.4.1 Electric diagram

Here follows the general electric diagram for both automatic and manual IN'PULSE:

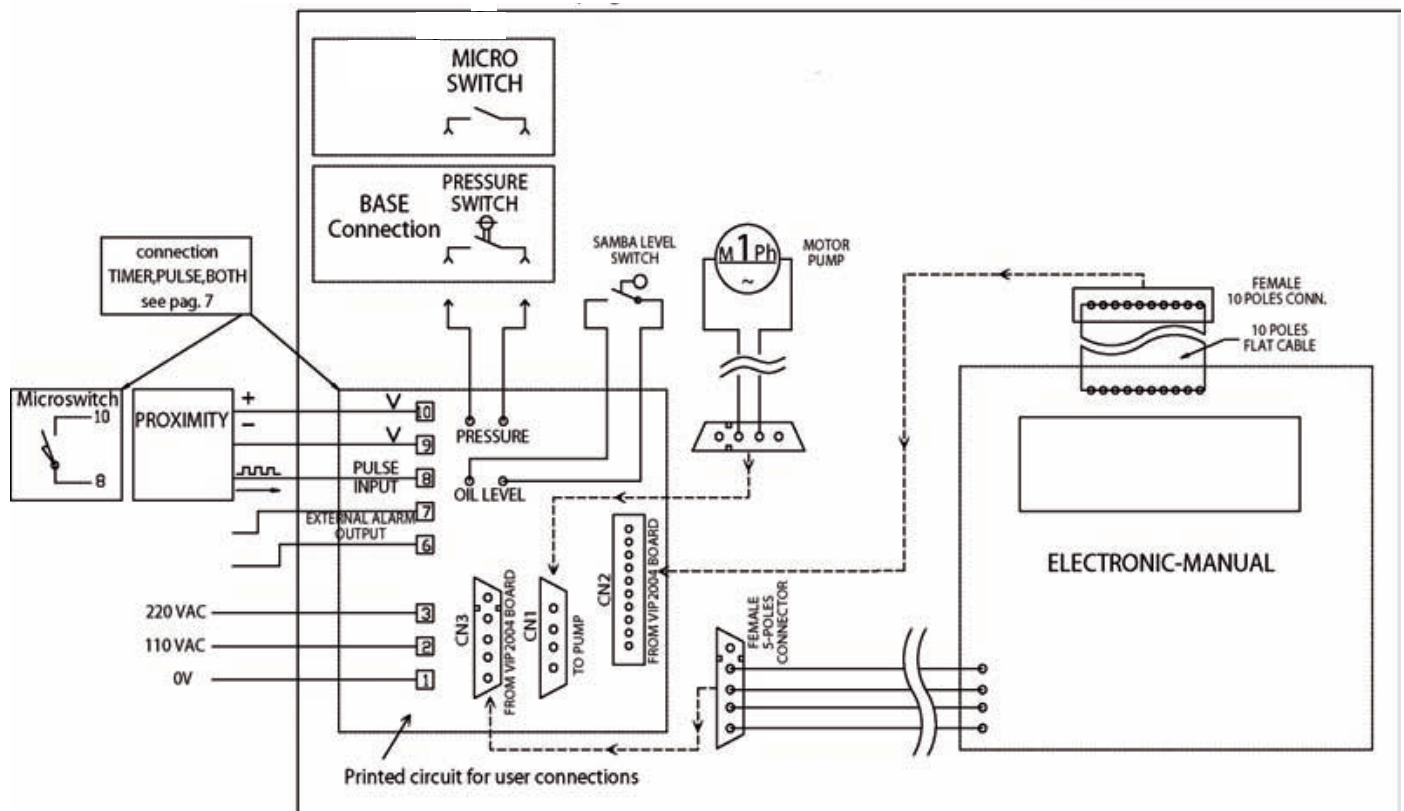

NOTICE: Pressure can be monitored by a micro-switch or a NPN/PNP proximity sensor.

7.4.2 User connections

The following picture shows the printed circuit for user connections, where the user has to connect power supply and external outputs for the correct functioning of both automatic and manual IN'PULSE. For details about connections, please refer to special paragraphs. (Printed circuit serigraphy only refers to automatic IN'PULSE. For the manual version there is a white label as showed in Fig. 2)

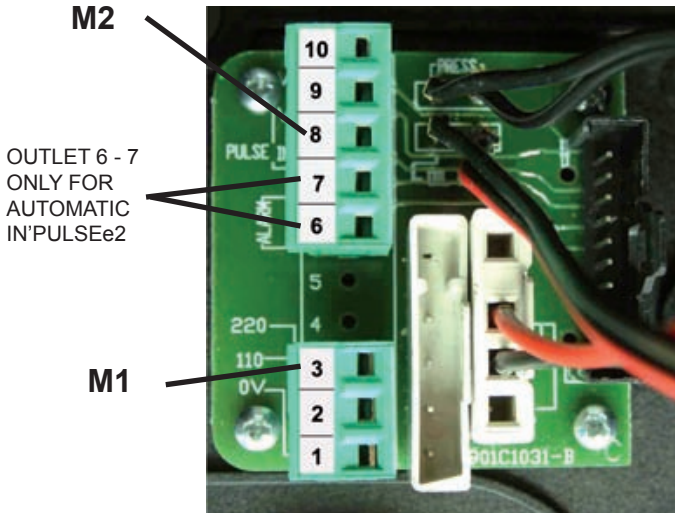

Fig. 1
Automatic version

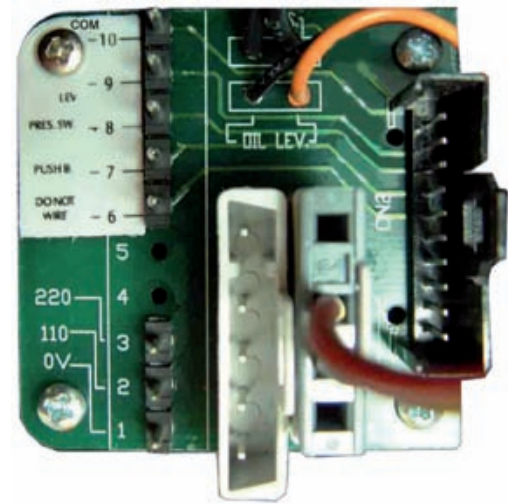
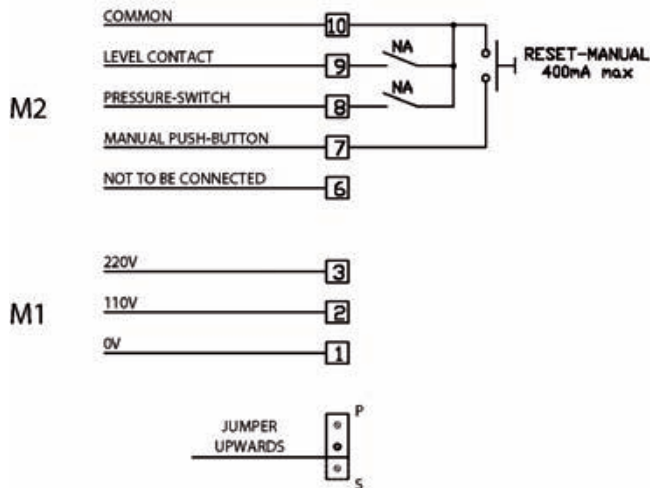

Fig. 2
Manual version

7.4.3. Connections for manual IN'PULSE

Here follows user connections for power supply (terminal M1), pressure-switch and electric level contact (independent or serial), and the manual push-button (terminal M2). Furthermore, it is also shown how to change the type of connection (independent or serial) for the pressure-switch and electric level contact, by acting on the jumper located on the electronic board of manual IN'PULSE.

INDEPENDANT CONNECTIONS PRESSURE-SWITCH AND MINIMUM LEVEL



SERIAL CONNECTIONS PRESSURE-SWITCH AND MINIMUM LEVEL

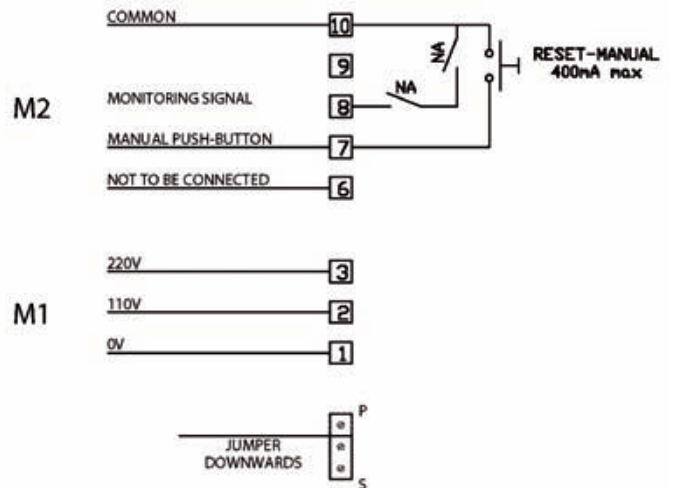

ALL CONTACTS MUST BE INTENDED "DOWN"
IF LUBRICAT IS ABSENT

7.4.4 Connections for automatic IN’PULSE

Here follows user connections for power supply (terminal board M1), external alarm (terminals 6-7) and proximity sensor or micro-switch (terminals 8-9-10). These last terminals have the function of stopping the timer or to register the pulse in order to define the standby duration. (See table A).

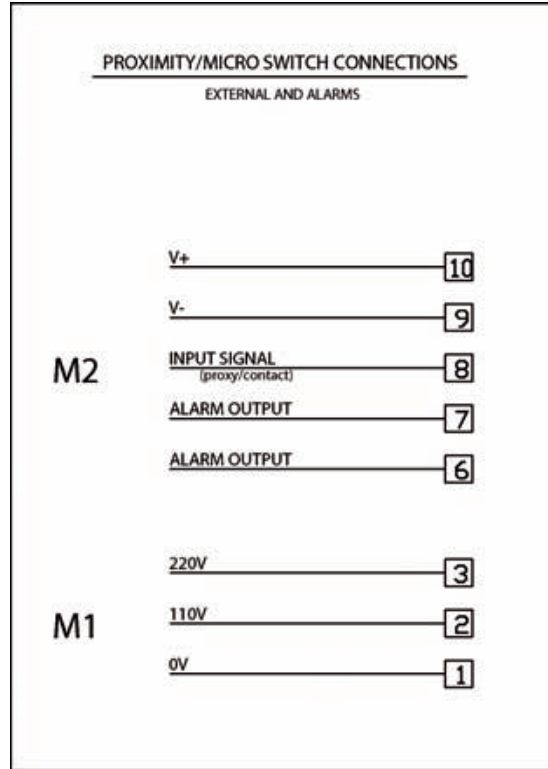

Input/output electrical specifications:

Power	See: 5.1 General technical specifications
Input signal	PNP proximity or N.O. free contacts input.
Alarm Output	Free contact: 250VAC –150 mA 125VAC/110VDC –300 mA 30VDC –1A

Table A :

Mode	Function
STAND BY TIMER	Stops the timer for standby duration
STAND BY PULSE	Decrements the pulse counter that defines standby duration (this function doesn't stop the timer)
STAND BY BOTH	Decrements the pulse counter that defines standby duration (this function doesn't stop the timer)

7.4.5 Power supply switch of the screen printed circuit board and screen brightness adjustment (Automatic IN’PULSE only)

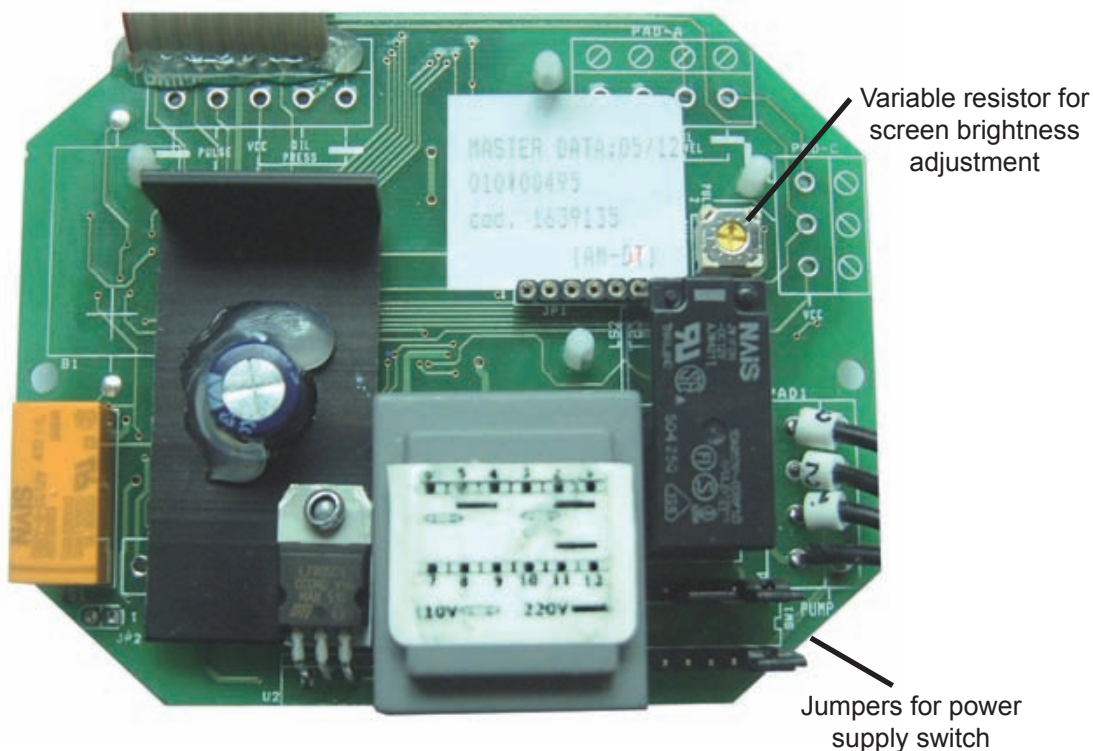

WARNING: Each time a powerfailure occurs, Date and Time are reset. It is recommended to setup Date and Time.

7.4.6 Precautions to be taken during connecting procedure

- ⇒ Prior to any operation, check the voltage of the machine on the product label.
- ⇒ In order to prevent dangers of electric shocks due to direct or indirect contact with the energized parts, electrical power supply line must be protected by a suitable magnetothermal 30mA differential circuit breaker with 1 second minimum operating time. Circuit breaker capacity must be 10 kA and nominal power In 4 A.

At the end of all connecting operations, make sure that hoses and wires are safe from impacts and carefully fixed.

8. INSTRUCTIONS FOR USE

8.1 MANUAL IN’PULSE

When the unit is equipped with the manual system, located on the frontal side panel you find the PUMP-ON indicator which is on when the pump is operating. Remote control is via external timer or PLC.

WARNING: Manual control device (reset button) connects the common signals that can be used as remote indication to PLC (or to another control system). It can be used, for instance, as indication to restart the lube cycle or to cancel an error on the pump. Max power absorption is 400mA.

8.2 AUTOMATIC IN'PULSE

When the unit is equipped with an automatic control, all the pump functions and checks are carried out through the built-in controller, alarms and external signals included. Timers are also controlled by the system. For details about machine operation, please refer to par. 8.4.

8.3 Machine operations

8.3.1 Prior to machine start-up

- Verify the unit is undamaged.
- Check that hydraulic and electric connections have been carefully carried out.
- Refill the reservoir with compatible lubricant.
- Verify the voltage: MAX 230VAC.

RESERVOIR REFILL

Use **ONLY** compatible lubricant and refill the reservoir by means of the oil refill plug provided with a filter. Do not pour lubricant directly into the reservoir without using this oil refill plug.

8.3.2 Machine start-up

In order to avoid damage to the machine, the unit must start operating at a minimum working temperature of +5°C (+41°F).

- Switch ON the unit (Green LED on)
- Verify unit start-up.
- Verify piping are air-bubble-free.
- Adjust pressure.
- Set-up machine parameters.
- Verify machine correct operation: pump must carry out lubrication correctly and according to parameters setup.

AIR VENTING

Pump well-functioning is not affected by presence of air in the system. However, it is advisable to vent air by starting the pump until lubricant comes out air-bubbles-free. (It is recommended to avoid pump operation when lubricant is below the minimum level).

PRESSURE REGULATION

Pressure can be verified via pressure gauge. It is possible to regulate pressure by acting on the screw located on the frontal side of the baseplate.

- ⇒ To increase pressure: turn the screw clockwise.
- ⇒ To decrease pressure: turn the screw anticlockwise.

In case of doubts as to correct machine functioning, it is recommended to contact our Eng. Dept. to request testing procedures.

8.4 IN'PULSE WITH BUILT-IN CONTROLLER OPERATION

8.4.1 Typical working session

Notice: prelube is always carried out according to prelube cycles set-up: if prelube cycles = '0', no prelube is run and the system will start operating either in standby or lube according to the pre-set start mode.

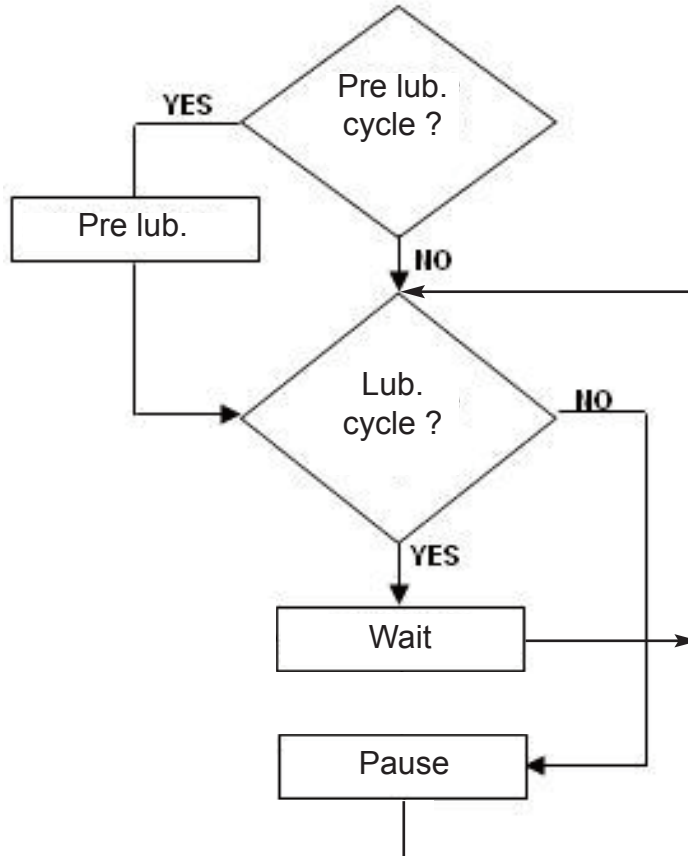

8.4.2 Typical system start-up

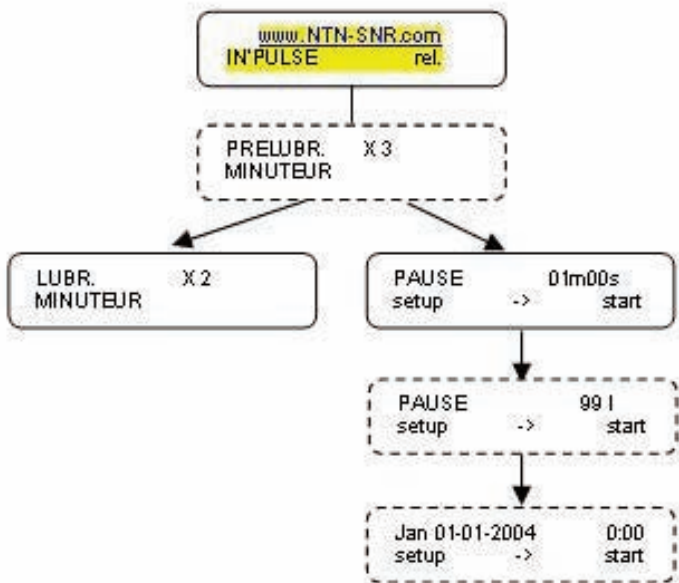

PRELUBE will be carried out only when prelube cycles are set (PRELUBE ≠ 0).

Whether prelube has been completely carried out (PRELUBE ≠ 0) or no prelube was set (PRELUBE = 0), LUBE or STANDBY will start (see start mode).

During standby, you can also see date and time when the function is enabled (see setup).

8.4.3 Setup session

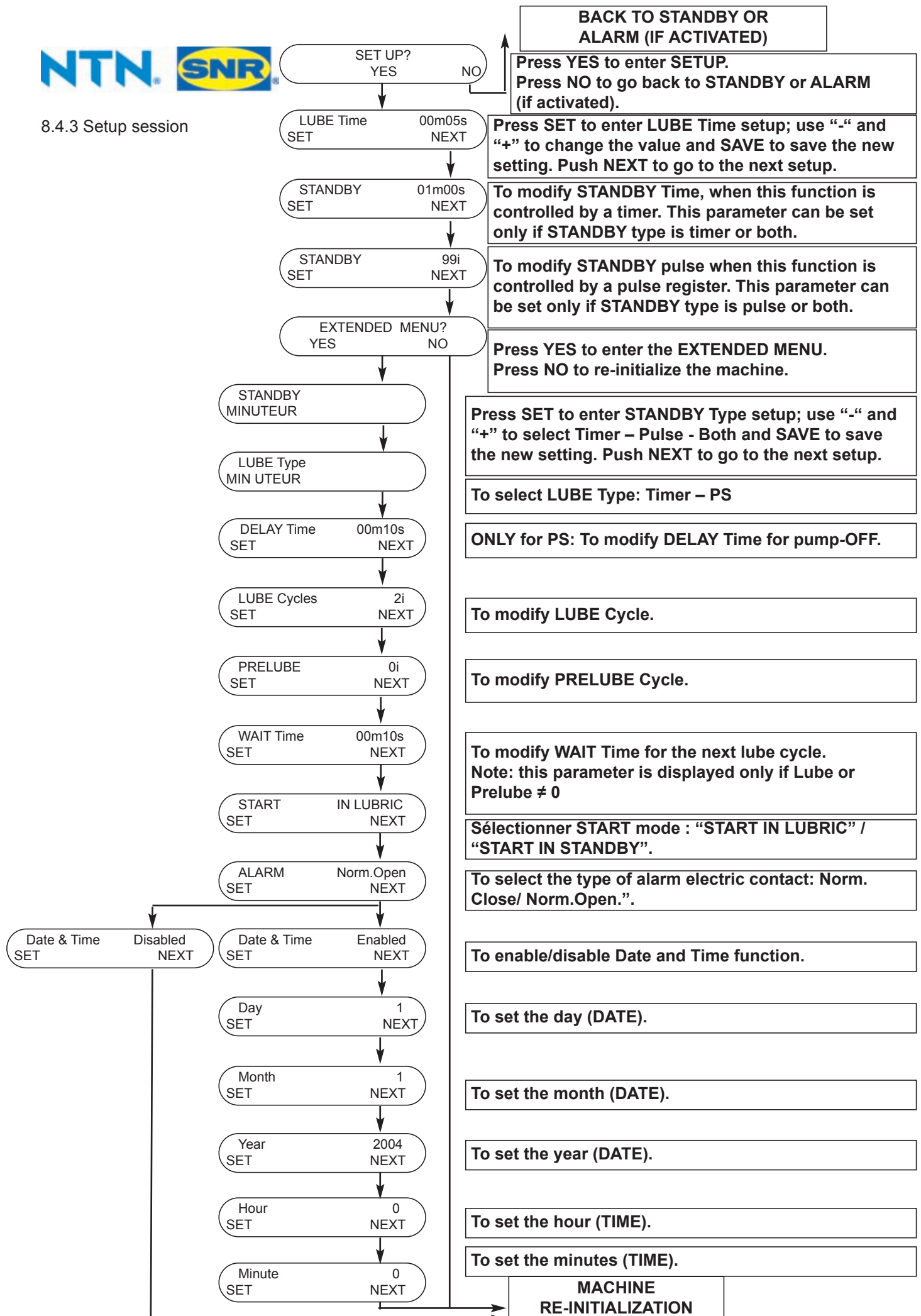

8.4.4 Operative parameters

Parameter		Description	Operative range	NTN-SNR setting
LUBE	Timer	A timer defines lube duration	00m01s to 4m59s	
	PS	Lube starts when system is in pressure (Pressure is monitored by a pressure-switch)	10s to 99 min.	
STANDBY	Timer	A timer defines standby duration (system idle)	01m00s to 999h59m59s	01m:00s
	Pulse	A pulse register defines standby duration (system idle)	1i to 9,999,999i	99i
	Both	Standby duration (system idle) is defined by both standby timers (timer and pulse), whichever occurs first.	See Standby Timer and pulse	01m:00s 99i
STANDBY		It allows to choose the type of standby.	Timer Pulse Both	Pulse
Lube type		It allows to choose the type of standby.	Timer PS	PS
DELAY TIME (FOR PS ONLY)		A timer defines the duration of PUMP ON (time lag for pump OFF) once the system goes in pressure	01s to 99 min.	00m:10s
LUBE Cycles		Number of lube cycles to be carried out by the system	01to 999	2
PRELUBE cycles		Number of prelube cycles, which will be carried out before the lube cycles)	1 to 999	0
WAIT Time		A timer defines the duration of a pause time between each lube process. <u>ONLY</u> for 'LUBE type: SEP': Set 00m00s for continuous service	01s to 16m39s	01m:00s
START MODE		It allows to choose how to start the working session	START IN LUBRIC	START IN LUBRIC.
			START IN STANDBY	
Alarm		It allows to choose the type of alarm electric contact	Norm. Open	Norm. Open
			Norm Close	
Date & Time		It allows to enable/disable Date & time display and setup	Enabled / Disabled	Enabled
Day		It allows to set the day	1-31	1
Month		It allows to set the month	1-12	1
Year		It allows to set the year	2000 to 2099	2000
Hour		It allows to set the hour	0-23	0
Minute		It allows to set the minutes	00-59	00

(*) Please see the Electric Diagram at page 6

9. TROUBLESHOOTING

WARNING: This unit can be opened and repaired by NTN-SNR Roulements personnel only

The following diagnostic table indicates the main anomalies which may be encountered, the probable causes and possible solutions. If you cannot solve the problem, do not attempt to disassemble the unit, but contact the Engineering Department of NTN-SNR Roulements

9.1 PUMP DIAGNOSTICS (MANUAL AND AUTOMATIC IN'PULSE)

Anomaly	Probable cause	Solution
Pump does not deliver lubricant. Pump does not deliver the fixed amount of lubricant	• Pump draws off air because the reservoir is empty.	→ Refill the reservoir and vent air from the system.
Pump delivers oil at an improper pressure	• Loosened inner fittings.	<input type="checkbox"/> → Retighten all the fittings. Be sure there are no Leakages.
	• Wear of the pump.	<input type="checkbox"/> → Replace the pump.
	• Wrong calibration of the by-pass valve.	<input type="checkbox"/> → Install a pressure gauge to adjust by-pass at the proper pressure.
The system stays in pressure at the end of the lube cycle	• Vent valve damaged or dirty.	<input type="checkbox"/> → Inspect and clean the valve. Replace it, if necessary.

9.2 CONTROLLER ALARMS (AUTOMATIC IN'PULSE)

When an alarm occurs, an external signal is ON. The display will show one of the following alarms for two seconds:

ALARM 01 – TIMER DEFAULT	Internal process error during lube by timer.
ALARM 02 - PX – VENT FAILED	At the beginning of lube by PS: it was detected that the system has not vented air.
ALARM 04 PS – PRESSURE ALARM	During lube by PS, it was detected that the system never goes in pressure.
ALARM 06 PS – PRESSURE LOSS	During lube by PS, even though the pump is operating, the system loses pressure.
ALARM 08 PS – GENERAL FAULT	Internal process error during lube by PS.
ALARM 11 – LOW LEVEL	The Samba Level Sensor detected low level. Refill the reservoir.

9.3 RESTART/RESET THE SYSTEM

Once one of the above alarm status occurs, another display will be shown:

For example:

ALARM 11
Setup Reset

There are two ways to restore machine operating:

⇒ By pressing setup (left push-button), the system will enter the setup session to modify, at any rate, parameters and re-start the machine.

⇒ By pressing reset for two seconds (right push-button or RESET button), the system will be reset and the machine will be re-initialized and will operate according to the last saved data setup.

10. MAINTENANCE PROCEDURE

NOTICE: The machine does not require any special tool for check or maintenance tasks. However, it is recommended the use only of appropriate and in good conditions tooling, protective devices (gloves) and clothing (626/94 and DPR 547/55) to avoid injury to persons or damage to machine parts.

WARNING: Prior to any maintenance, be sure that the power and the hydraulic supplies are off and there is no residual pressure in the main/branch pipe.

IN'PULSE has been designed and manufactured to require the minimum maintenance. Anyway, it is recommended :

- To keep the unit clean and periodically to check pipe joints to readily detect possible leaks.

WARNING: It is recommended the use of impurity-free lubricant.

PERIODICAL MAINTENANCE

Inspection	Number of work cycles	Maintenance Procedure
Lubrication	1000	-
Cleanliness of refill filter	4000	Replace the refill filter, if necessary
Cleanliness of reservoir	6000	Clean the bottom of the reservoir in case of impurities

11. DISPOSAL

During maintenance or disposal of the machine care should be taken to properly dispose of environmentally sensitive items. Refer to local regulations in force in your area.

When disposing of this unit, it is important to ensure that the identification label and all the other relative documents are also destroyed.

12. DIMENSIONS : Weight 4 kg (8,8 lbs)

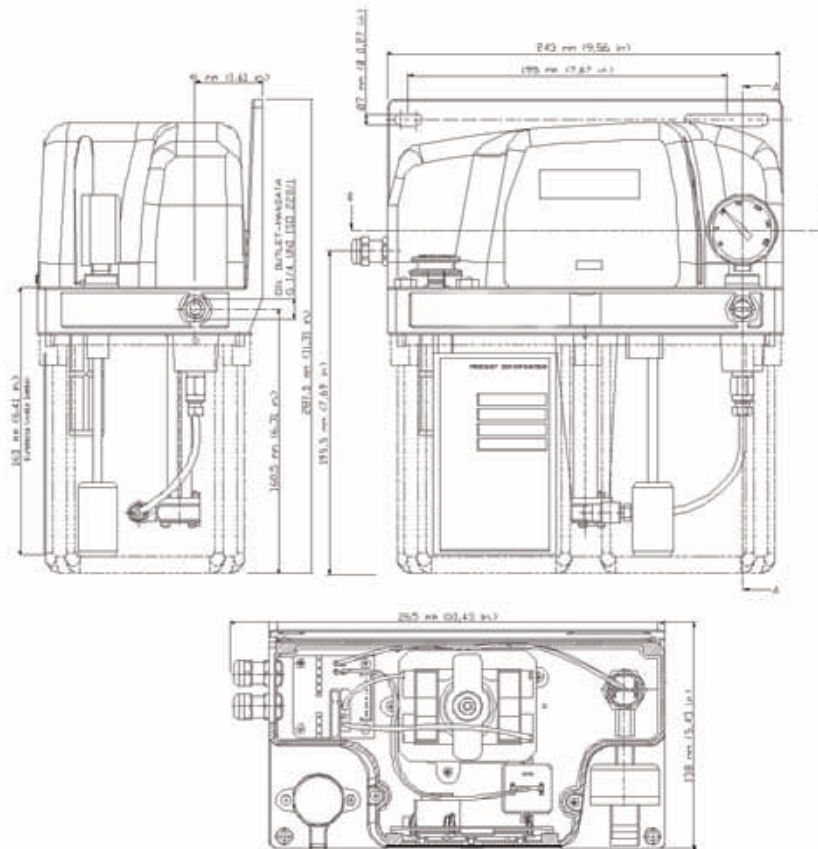

13. HANDLING AND TRANSPORTATION

Prior to shipping, the equipment is carefully packed in cardboard package. During transportation and storage, always maintain the pump the right way up as indicated on the box. On receipt check that package has not been damaged. Then, storage the machine in a dry location.

⇒ Due to machine contained weight and size, it is not necessary the use of material handling equipment. Anyway, we recommend to lift the equipment observing the right way up shown on the cardboard package.

14. OPERATING HAZARDS

WARNING: It is necessary to carefully read about the instructions and the risks involved in the use of lubrication machines. The operator must know the machine functioning through the User and Maintenance Manual.

It is necessary to carefully read the warnings and the risks involved in using the lubrication panel. The operator must understand the functioning of the unit by studying the user's manual.

Electric currents

No intervention must be attempted on the equipment without first having disconnected the electrical power supply and ensuring that it cannot be reconnected during the intervention.

All installed equipment, electrical, electronic, tank and base structure, must be connected to the ground line utilizing the terminals fitted to each component.

Flammability

The oil employed in the lubrication circuit is not normally flammable. It is nonetheless indispensable to take every precaution against the oil coming into contact with very hot parts or open flames.

Pressure

Prior to any intervention on the equipment ensure that pressure is released from all branches of the lubrication circuit. Failure to do this could result in oil being discharged under pressure where connections or components are disassembled.

Noise

The AIR'PULSE lubrication panel does not emit excessive noise, remaining below 70dB(A).

WARNING: before carrying out the replacement of the mini-pumps, empty the tank of lubricant.

15. CONTRAINDICATIONS

No particular operating hazards characterize the machine, except for the following precautions:

- Operator's contact with the lubricant in case of piping breaking/opening or during refill/maintenance. -> Protection against direct and indirect contact with the fluid must be provided by the user: the operator must be provided with suitable individual protective clothing and devices (tit VIII – 626).
- Use of incompatible lubricant. Main unauthorized fluids:

Fluids	Dangers
Lubricants containing abrasive components	Premature wear of pump
Lubricants containing silicon	Pump failure
Petrol – solvents – inflammable liquids	Fire – explosion – seal damage
Corrosive products	Pump damage - danger to persons
Water	Pump oxidization
Food Products	Contamination of the product

16. WARRANTY INFORMATION

All products manufactured and marketed by NTN-SNR Roulements are warranted to be free of defects in material or workmanship for a period of at least 12 months from date of delivery.

Extended warranty coverage if complete system installation by NTN-SNR Roulements: 12 Months.

If a fault develops, notify NTN-SNR giving:

- a complete description of the alleged malfunction
- the part number(s)
- date of delivery
- date of installation
- operating conditions of subject product(s)

NTN - SNR Roulements reserves the right to charge an administration fee if the product(s) returned are found to be not defective.

This limited warranty does not cover any products, damages or injuries resulting from misuse, neglect, normal expected wear, chemically caused corrosion, improper installation or operation contrary to factory recommendation. Nor does it cover equipment that has been modified, tampered with or altered without authorization.

Consumables and perishable products are excluded from this or any other warranty.

No other extended liabilities are stated or implied and this warranty in no event covers incidental or consequential damages, injuries or costs resulting from any such defective product(s).

The use of NTN-SNR product(s) implies the acceptance of our warranty conditions. Modifications to our standard warranty must be made in writing and approved by NTN-SNR Roulements.

Web site: <http://www.NTN-SNR.com> - E-mail: expertsandtools@ntn-snr.com

17. DECLARATION OF CONFORMITY

DECLARATION OF COMPLIANCE WITH STANDARDS

NTN-SNR Roulements, registered in Annecy, rue des Usines,

CERTIFIES :

that the machine IN'PULSE pump
has been constructed in conformity with the DIRECTIVES OF THE COUNCIL OF THE EUROPEAN
COMMUNITY on the standardization of the legislations of member states:

- 2006/42 Machinery Directive
- 73/23 Low voltage Directive
- 86/336 Electromagnetic compatibility directive

Observing every safety and health essential requirements, with reference to the following standards:

- EN 12100-1/2 Safety of machinery - basic concepts/design principles.
- EN 1050 Safety of machinery - risk assessment principles.
- EN 982 Safety of machinery - fluid and pneumatic power systems and components safety requirements.
- EN 11200 Noise emitted by machinery and equipment.
- EN 894-1/2/3 Ergonomic requirements for information and control devices design.
- EN 60204-1 Safety of machinery. Electrical equipment of machines.

Annecy, July 2010

NTN-SNR Roulements

Christophe Oddoux,
General Manager Experts & Tools

Christophe Benier,
Product Manager Experts & Tools



Web site: <http://www.ntn-snr.com> - E-mail: expertsandtools@ntnsnr.com

Web site: www.ntn-snr.com - E-mail: expertsandtools@ntn-snr.com

LUB SOLUTIONS : The Products and Services offer designed to bring you lubrication solutions. Specifically selected for your different applications, a choice of lubricants is offered as well as a full range of reliable systems to dispense them with precision on each mechanical organ.

LUB SOLUTIONS are above all experts to support you while setting up lubrication systems adapted to your environment. From advices to specify your needs to the implementation of your lubrication system, including their manufacturing, rely on our experts to bring you the right solution.

Experts & Tools offer also maintenance tools, specifically designed for bearing fitting and removal.

Should you require more info, please ask for our "Maintenance tool catalogue" or visit our Internet website www.ntn-snr.com



“Bringing you a complete tools and services solution for your bearings, suited to your application, size and resources.”

Experts & Tools 