

INDUSTRY MAINTENANCE TOOLS

NTN **SNR**

www.ntn-snr.com



With You

Experts & Tools

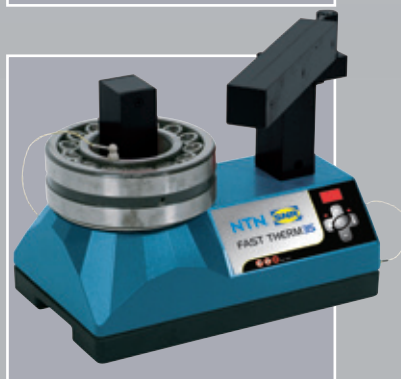



“You provide a complete solution of tools and services for your bearings, suited to your application, size and resources”

Experts
& Tools

NTN-SNR Expert & Tools, at the service of our customers

Because expectations for the maintenance and mounting of bearings are specific to each customer, Experts & Tools offers you solutions that take into account your application and its importance to you as an available resource.

Each application requires special expertise. Maintaining a wind turbine is different to maintaining a printing press or a meat mincer. With the theoretical and practical experience we have accumulated over almost a century of dealing with industrial applications, NTN-SNR can provide you with the expertise and tools you need.

The scale and difficulty of your mounting and maintenance tasks determine our recommendations. We provide a customised response in terms of tools and organisation, suited to your situation.

► **The NTN-SNR Group**, with more than 21,000 employees worldwide, produces and improves maintenance tools and methods on a daily basis. Our aim is to bring you products and procedures that are safe and easy for your staff to use. The design of our tools is aimed at increasing your efficiency.

By reducing the amount of time it takes for mounting, dismantling as well as maintenance operations, and by maximising the working life of your bearings, our tools provide you with real savings and safety in use and will not damage the machinery they are being used on.

This catalogue contains the entire range of NTN-SNR maintenance tools. Our range of greases, greasers and centralised lubrication systems is contained in a separate catalogue.

► **And if you decide to sub-contract your maintenance operations?**

The Experts & Tools teams can take care of this, based on agreed availability targets for your machinery.

Experts & Tools offers you a range of services that can be customised to meet your specific requirements:

- **Theoretical** and practical training for your employees.
- **Expertise** on your damaged bearings (on site or in our laboratories).
- **Supervision** of the dismantling or mounting of your critical bearings. Of particular interest for larger bearings where we can supply appropriate tools, including handling tools.
- **Rental** of maintenance tools: bearing heaters, hydraulic nuts and pumps, etc.
- **Diagnosis** of your lubrication installations or an analysis of your needs, with the production and installation of appropriate standard or customised equipment.
- **Renovation** of bearings removed from equipment as part of a preventive maintenance programme.

MAIN CAUSES OF FAILURES OF YOUR BEARINGS

► The monitoring of the millions of NTN-SNR bearings sold has allowed us to establish very precise statistics on the origin of faults. This collection of data highlights one essential fact: it is rare that the bearing itself is the cause of a premature failure.

In 90% of cases, the causes can be found in external components which can be classified into four categories:

INAPPROPRIATE LUBRICATION (55%)

Inappropriate or incorrect lubrication significantly reduces the service life of the bearing.

It is often neglected because of bearing accessibility problems and a lack of knowledge about lubricants on the part of the user.

The choice of lubricant, the method, the quantity to apply to the bearing (neither too much nor too little) and the monitoring frequency must be properly studied.

NTN-SNR offers you a special service and markets a complete range of greases covering all applications, as well as an automatic greasing system.

INCORRECT MOUNTING (17%)

The mounting of a bearing on a machine is a key stage in determining the length of its life. A bearing that is not mounted correctly can deteriorate very quickly.

The main causes are:

- *Insufficient or poorly adapted methods and resources,*
- *Contamination during mounting,*
- *The use of force during mounting,*
- *Poor preparation of the receiving components: shafts and housings outside tolerance, poor access for the lubricant, misalignment.*

Abnormal noise levels can be a warning sign of deterioration. In the short term this causes fatigue of the bearing surfaces. NTN-SNR can provide you with mounting and dismounting services or tools and equipment to make these operations easier and more secure.

POLLUTION (18%)

The environment in which bearings operate is often highly polluted. Dust, liquid detergents, and other contaminants can severely reduce the working life of a bearing.

To deal with these problems, NTN-SNR has developed a comprehensive range of sealing systems and will be pleased to advise you on the best choice for your application.

FATIGUE (10%)

Bearings are key components and are subject to fatigue. Even more so since they rarely operate in ideal conditions (overloaded machine, insufficient lubrication, etc.)

The stresses that active surfaces of bearings are subjected to create surface pitting damage sooner or later.

Our monitoring methods and support from our experts will enable you to act on the first indication of failure and organise appropriate maintenance operations.



GENERAL CONTENTS

P. 7 MOUNTING & REMOVAL

- Cold mounting 8
- Hot mounting 12
- Mechanical dismounting 17
- Hydraulic mounting and dismounting 26



P. 31 SAFETY & MEASUREMENT

- Safety instrument 32
- Measurement instruments 32



P. 35 TECHNICAL DATA

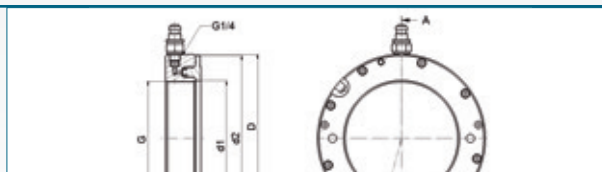

P. 54 GLOSSARY

TOOL HS (min. size –max. size) / HOOK SPANNER	Articulated manual hook spanner
TOOL IFT SET 33 / INDUSTRY FITTING TOOL SET	Mounting tool kit with 33 pieces
FAST THERMUS 301 / IR THERMOMETER	Infrared thermometer targeting ratio 30 : 1



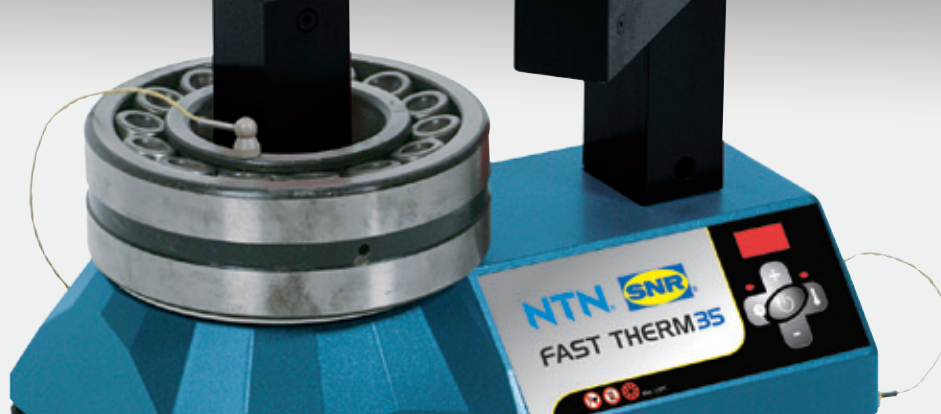

CONTENTS

MOUNTING & DISMOUNTING

P. 8 GOLD MOUNTING

- Mounting tool kit case 9
- Anti-fretting paste 11
- Adjustable spanners 11

P. 12 HOT MOUNTING

- Heating equipment 14

P. 17 MECHANICAL DISMOUNTING

- Bore puller kits 18
- Deep-groove ball bearings extractor kit 19
- Self-centering mechanical puller 20
- Self-centering hydraulic puller 21
- Case of accessories for hydraulic puller 22
- Tri-section pulling plate 23
- Puller - separator kit 24
- Hydraulic puller for mounting and dismounting 25

P. 26 HYDRAULIC MOUNTING AND DISMOUNTING

- Hydraulic nuts 28
- Manual hydraulic pump kits 29
- Extended tubes 30

MOUNTING & REMOVAL COLD

GOOD PRACTICES FOR COLD MOUNTING





Cold mounting is the simplest method and is suitable for small and medium-sized bearings, completed with the normal adjustments.

OUR RECOMMENDATIONS:

The most frequently observed problems:

- Over- or under-tightening when adjusting.
- Excessive impacts during mounting or forces causing rings and seals to break, or races to become indented.
- The accidental introduction of particles or liquids present in the mounting environment.

➤ The bearing must be tightened on the rotating element to which it is fitted. See table below.

	Analysis of rotation (% Incidence)		Retention method
Fixed load with respect to the outer ring	Fixed housing and load (95%)  Rotating inner ring	Rotating housing and load (0.5%)  Stationary inner ring	Inner ring tightened on shaft
Fixed load with respect to the inner ring	Stationary shaft and load (3%)  Rotating outer ring	Rotating shaft and load (1.5%)  Fixed outer ring	Outer ring tight in housing

OUR RECOMMENDATIONS TO BE FOLLOWED:

- Check bearing identifying marks against drawings, specifications and procedures.
- Check that bearing seat dimensions and the accuracy of their shape and position correspond to NTN-SNR drawings and specifications.
- Prepare all equipment, tools and parts required before commencing assembly.
- Carefully clean and check all parts and devices in the bearing's environment.
- Remove the bearing from its packaging at the last moment in a completely clean working area.

- Never wash it, except in specified exceptional cases. The bearing is protected from oxidation by a light film of oil compatible with all lubricants.
- Mount the bearing, using the chosen method.
- Lubricate, using a special bearing grease, following the instructions given.
- After mounting and before final start-up, check its operation, so as to detect any possible anomalies (noise, vibrations, temperature, abnormal play, etc.).

IN PRACTICE:

➤ The sleeve is mounted by means of impact rings applied against the bearing ring which has the tightest fit. This avoids stressing the rotating body and damaging the bearing.

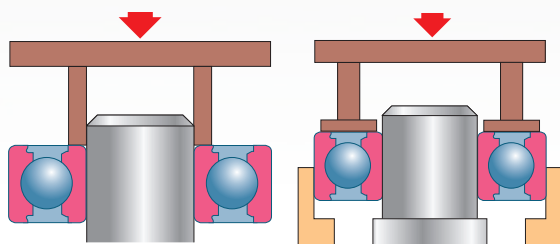

➤ In the case of a long shaft for mounting requiring longitudinal adjustment of the bearing, we prefer using a mechanical sleeve with tapered contact surface associated with ng with tapered bore.



➤ WHAT THE NTN-SNR EXPERTS HAVE TO SAY:

For easier mounting and to avoid contact corrosion of the shaft or the housing, always use an anti-fretting paste. This thick lubricant helps preserve the quality of parts surfaces subjected to sliding forces. Without this compound, corrosion would progressively cause the fit between bearing and shaft (or housing) to deteriorate, ultimately leading to vibrations and even the premature deterioration of the bearing and its mounting surfaces.

The anti-fretting paste also avoids introducing any pollutant during assembly (metal chips, liquid, etc.)



COLD MOUNTING TOOL KIT CASE

36

The NTN-SNR tool kit enables the quick, accurate and safe mounting of bearings.



APPLICATIONS

The use of a suitable socket, associated with the mounting sleeve, enables to install the bearing to the desired adjustment. The simultaneous support of the outer and inner rings prevents the risk of deterioration of the races and rotating assemblies. The kit can also be used for assembling other components such as sealing rings, pinions and pulleys.

ADVANTAGES

Of light and strong construction for workshop use, this toolbox contains:

33 impact rings:

- Very robust for a long working life.
- In impact-resistant, synthetic material, avoiding any metal-to-metal contact.
- Ideal for use in conjunction with a press.
- Calibrated for approximately 400 different bearings:
 - with bore diameters between 10 and 50 mm
 - and with outside diameters between 26 and 110 mm
- Clearly and permanently identified to aid selection.

3 mounting sleeves:

- Light and extremely robust, made of aluminium.
- With a good grip for the hand.

1 special dead blow mallet, ensuring optimum impact force is applied.

COMMERCIAL REFERENCE

TOOL IFT SET 33 / Industry Fitting Tool Set

SPARE PARTS (to order)

- **Impact ring**
TOOL IMPACT RING (tube A,B,C), socket
Example: *TOOL IMPACT RING A 10-25*
- **Dead-blow mallet**
TOOL IMPACT RING HAMMER
- **Mounting sleeve**
TOOL IMPACT RING SLEEVE (tube A,B,C)
Example: *TOOL IMPACT RING SLEEVE A*
- **Socket for mounting sleeve**
TOOL IMPACT RING LOOSE RING (tube A,B,C)
Example: *TOOL IMPACT RING LOOSE RING A*

Mounting sleeve

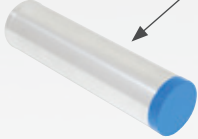

Socket for the mounting sleeve



Impact ring



Dead-blow Mallet

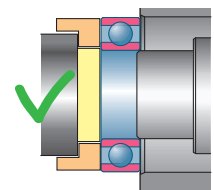
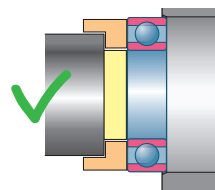
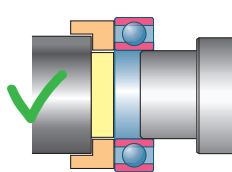
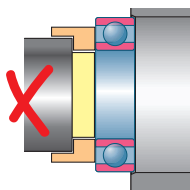
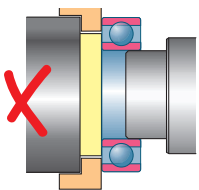

39

This symbol, close to each product, informs you on which page you can find technical characteristics.

MOUNTING & REMOVAL COLD

COLD MOUNTING TOOL KIT CASE - TECHNICAL DATA

Ref. Tubes	Ref. Bushings	Series 60 62 63 64 16 62/63/98	Series 622 623 630	Series 12 22 13 23	Series 72 73	Series 32 52 33 53	Series 213 222 223	Series 10 2 3 22 23	Series C22 C40	Series 42 43	
A	10 / 26	629 16100 6000	63000	129							
	10 / 30	6200	62200	1200 2200	7200	3200 5200				4200	
	10 / 35 12 / 28	6300 6001 16101	62300 63001								
	12 / 32	6201	62201	1201 2201	7201	3201 5201				4201	
	12 / 37	6301	62301	1301 2301	7301					4301	
	15 / 32	16002 6002 6202	63002					202		4202	
	15 / 35	6302	62302	1202 2203 1302 2302	7202 7302	3202 5202 3302 5302					
	17 / 35	16003 6003	63003								
	17 / 40	98203 6203	62203	1203 2203	7203	3203 5203		203 2203		4302 4203	
	17 / 47	6303	62303	1303 2303	7303	3303 5303		303		4303	
	B	20 / 42	16004 98204 6004	63004							
		20 / 47	6204	62204	1204 2204	7204	3204 5204		204 2204		4204
		20 / 52	6304	62304	1304 2304	7304	3304 5306	22205/20	304 2304		4304
		25 / 47	16005 6005 62/22	63005					1005		
25 / 52		98205 6205 63/22	62205	1205 2205	7205	3205 5205	22205	205 2205	C2205	4205	
25 / 62		6305 6403	62305	1305 2305	7305	3305 5305	21305	305 2305		4305	
30 / 55		16006 6006 62/28	63006					1006	C6006	4206	
30 / 62		98206 6206 63/28	62206	1206 2206	7206	3206 5206	22206 BS2-2206	206 2206	C2206		
30 / 72		6306 6404	62306	1306 2306	7306	3306 5306	21306 2306	306		4306	
C		35 / 62	16007 6007	63007					1007		
		35 / 72	6207	62207	1207 2207	7207	3207 5207	22207 BS2-2207	207 2207	C2207	4207
		35 / 80	6307 6405	62307	1307 2307	7307	3307 5307	21307	307 2307		4307
		40 / 68	16008 6008	63008					1008		
		40 / 80	6208	62208	1208 2208	7208	3208 5208	22208 BS2-2208	208 2208	C2208	4208
	40 / 90	6308 6406	62308	1308 1308	7308	3308 5308	21308 22308	308 2308		4308	
	45 / 75	16009 6009	63009					1009			
	45 / 85	6209	62209	1209 2209	7209	3209 5209	22209 BS2-2209	209 2209	C2209	4209	
	45 / 100	6309 6407	62309	1309 2309	7309	3309 5309	21309 22309	309 2309		4309	
	50 / 80	16010 6010	63010					1010	C4010		
	50 / 90	6210	62210	1210 2210	7210	3210 5210	22210 BS2-2210	210 2210	C2210	4210	
	50 / 110	6310 6408	62310	1310 2310	7310	3310 5310	21310 22310	310 2310		4310	

ANTI-FRETTING PASTE

The NTN-SNR anti-fretting paste is specially designed to prevent contact rust between 2 metal surfaces.

36



APPLICATIONS

- Contact corrosion, also known as fretting corrosion, appears in assemblies subjected to vibration or very slight slippage or oscillation. It can lead to the serious deterioration of bearings and other machine components and thus make dismantling very difficult.

ADVANTAGES

- Allows slippage for assemblies with play (wheel bearings, vibrating screens, etc.).
- Preserves the quality of the surfaces and the adjustment of mechanical assemblies by preventing contact (fretting) corrosion.
- Facilitates the mounting and dismantling of bearings and components such as nuts, bolts, pins, flanges, couplings, fluted shafts, etc.
- Water and washing resistant.
- Temperature range for use -40°C to +150°C.

COMMERCIAL REFERENCES

LUB ANTI FRETTING PASTE / T 60G
LUB ANTI FRETTING PASTE / B 750G

ADJUSTABLE SPANNERS

10 spanners for tightening and loosening up to 30 differently sized nuts!

36



APPLICATIONS

- NTN-SNR adjustable spanners enable the safe and effortless tightening and loosening of all KM, KML and KMK type nuts and also B, TB, BR and TBR precision nuts. They avoid any damage to the nuts or the shaft.

ADVANTAGES

- Made of special tempered steel, these spanners are extremely strong.
- The joint with its spring washer guarantees gentle reliable operation.
- The laser-etched imprint makes them easily and permanently identifiable.
- The hole in the handle makes them easy to store.
- They are adaptable to cover nut diameters from 15 to 180 mm.

Available in two versions:

With pins for nuts with holes

With hook for slotted nuts



COMMERCIAL REFERENCES

TOOL PS (size) / Pin Spanner (with pin)
TOOL HS (size) / Hook Spanner (with hook)

MOUNTING & REMOVAL HOT

GOOD PRACTICES FOR HOT MOUNTING

Hot mounting makes it possible, by raising the bearing's temperature, to expand the inner ring so that it can be fitted over the shaft with ease.

- In the event of tight fitting on the outer ring, prior to the insertion of the bearing, the housing may be made to expand through heating.
- Conversely, a shaft can also be cooled using liquefied gas in order to facilitate its insertion into the inner ring of the bearing.

NTN-SNR's induction heaters provide the best solution in terms of safety, cleanliness and speed compared with oil-bath heating, hot plates or ovens.

Heating using a blowtorch is to be prohibited: it generates localised temperatures that alter the hardness of the bearing and therefore shorten its service life.

PRINCIPLE OF HEATING BY INDUCTION

The device comprises of a laminated steel core surrounded by a coil with multiple windings. When a current passes through it, this primary coil generates a magnetic field which itself induces an electric current in the bearing (or other steel part), substituted for the secondary coil of an electrical transformer.

When a high-intensity, low-voltage AC current passes through it, the bearing heats up quickly; while non-metallic parts and the device itself remain cool.

Induction heating magnetises the bearing. It is therefore necessary for the heater to demagnetise it at the end of the heating cycle. This avoids steel particles being attracted into the bearing later on.

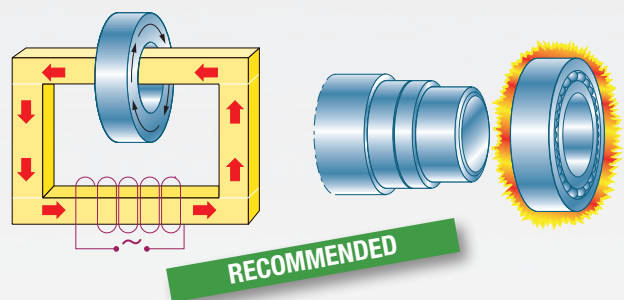
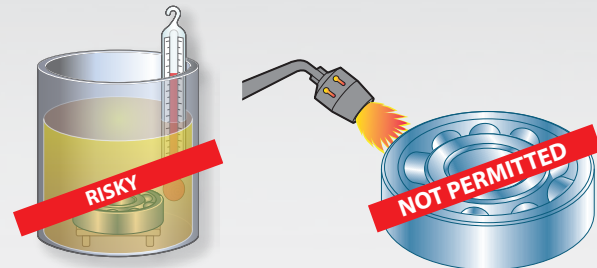

WHAT THE NTN-SNR EXPERTS HAVE TO SAY:

The temperature should not be too high so as not to modify the characteristics of the steel (maximum 130°C) or of the internal components of the bearing. On the other hand, the temperature must be high enough to generate sufficient expansion for the easy installation of the bearing through temporarily loosening the fit.

The heating temperature is a function of the ambient temperature, on the one hand and the fit of the seat on the other.

The mounting of a bearing onto a shaft or into a housing requires a certain skill for proper alignment. The use of anti-fretting paste facilitates insertion and protects the shaft or housing from contact corrosion.

The wearing of heat insulating gloves is essential for the safe and comfortable handling of the heated parts.

In the case of heavy bearings, help will be required for their handling (use of a textile sling and mobile hoist or even an overhead crane).

THE RIGHT QUESTIONS TO ASK YOURSELF WHEN SELECTING A HEATING DEVICE

- How big are the parts to be heated? (*Max. external diameter, max. width, min. and max. bore*)
- What are the min. and max. weights of the parts?
- What temperature has to be achieved?
- What electrical current and voltage are available in the workshop?

THE MAJOR ADVANTAGES OF THE FAST THERM AND SAFE THERM RANGE:

PRACTICAL AND SIMPLE IN USE

- Robust design for use in an industrial environment.
- Ready for immediate use.
- Requires no maintenance.
- The ergonomic, pivoting yoke of the 35, 150 and 300 models facilitates the positioning of the parts to be heated.
- User-friendly; the touch-screen controls can be operated while wearing protective gloves:
 - Only three buttons are required to programme the portable version (two for setting the temperature (+40°C to +240°C), and one to start),
 - 2 additional buttons on the other versions also enable control of the "heating time" (0 to 99 min),
 - Display of the temperature and time and also error codes for quick troubleshooting.
- Audible signal at the end of the heating cycle.
- Choice of °C or °F temperature display.

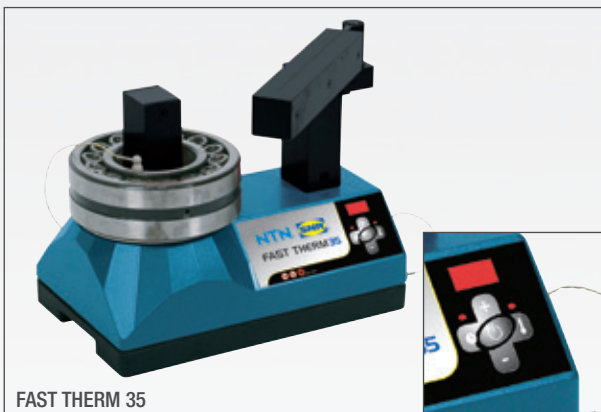

FAST THERM 35

HEATING CONTROL AND SAFETY

- Optimum control of the heating cycle by microprocessor and magnetic temperature probe.
 - Quick even heating of parts and no risk of over-heating.
 - The equipment uses a default temperature of 110°C.
 - Maximum heating temperature: +240°C.
 - Automatic demagnetising at the end of the cycle.
 - Ability to control the heating time to achieve a steady temperature rise and avoid stressing the bearing (Safe Therm 700 and 1200).
- ▶ The bearing's initial quality is maintained.
- Stop/start the device via an infrared remote control (Safe Therm 700 and 1200).
 - Only the part to be heated is subjected to an increase in temperature (easier handling, no risk of burning).
 - Thermal insulation of the magnetic probe.
 - Meets EEC legislative standards.

▶ Operator safety ensured.

ROBUST AND EFFICIENT

- Robust industrial design, guaranteed for three years.
- Oil-, dust- and water-resistant control screen.
- Quick and economical with its TURBO-BOOST operating mode.
- In a horizontal position (placed on a polyamide base), the part heats twice as quickly.
- Efficient, it is no longer necessary to heat the same part several times to keep it at the desired temperature. As soon as the temperature drops 5°C, the machine automatically resumes the heating cycle. This resumption occurs over five consecutive cycles.

ENVIRONMENT-FRIENDLY

- No fumes or oil vapour.
- Excellent energy yield (approx. 80%), thus guaranteeing:
 - Savings in time and energy,
 - A longer life for the appliance.

Delivered as standard with a temperature probe, protective gloves and instruction manual.

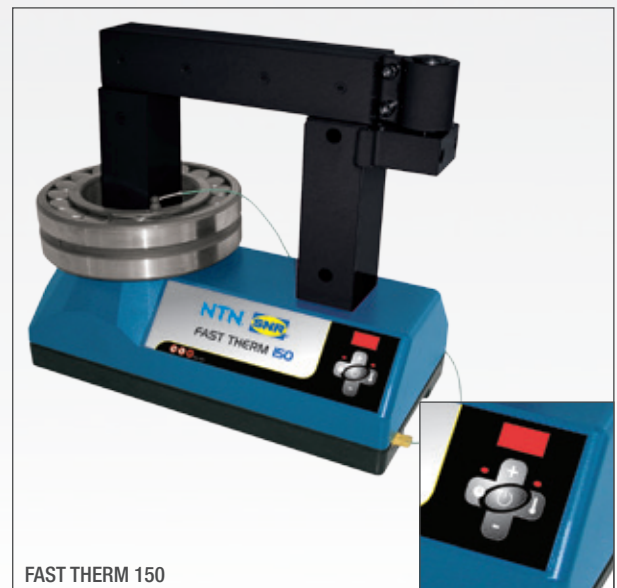

FAST THERM 150

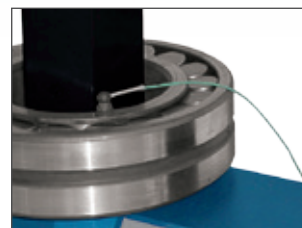

FAST THERM PROBE
(temperature probe)



HEATING EQUIPMENT

FAST THERM 20

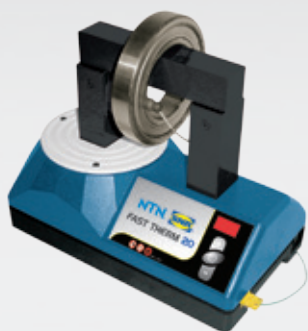

Portable induction heater.
Light and easy to use, can heat a bearing of up to 40KG.

▶ 38

ADVANTAGES

- Small, **light heater**: weight only 17 kg.
- **Easy to use**, ideal for working on site.
- Designed for all bearings and rotating parts with a bore diameter above 10 mm with a maximum diameter of **280 mm** and a maximum weight of **40 kg**.

Delivered as standard with its 3 core bars, a pair of gloves and a probe in a sturdy carrying case.

COMMERCIAL REFERENCE

TOOL FAST THERM 20 / Induction heater



FAST THERM 35

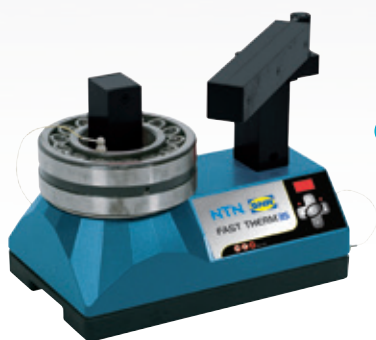

Induction heater with pivoting arm, best-seller of maintenance or production workshops, which can heat a bearing of up to 70KG.

▶ 38

ADVANTAGES

- Used as fixed equipment.
- **Compact**, it weighs only 35 kg and can be easily moved using its two side handles.
- **Multiple uses**: apart from the temperature control mode, it also has, like all the larger models, a heating time control for large parts (shrink-on rings, pinions, pulleys, etc.).
- **Ergonomic**: the **standard pivoting arm** facilitates the loading of the parts to be heated.
- Designed for all bearings and rotating parts with a bore diameter above 15 mm with a maximum diameter of **410 mm** and a maximum weight of **70 kg**.

Delivered as standard with the core bar for bore diameters of 70 mm or more.

Four other available yoke sizes are available as an option and may be ordered to suit the application.

COMMERCIAL REFERENCE

TOOL FAST THERM 35 / Induction heater

FAST THERM 150

Compact and economical induction heater, providing high heating power for bearings up to 150 kg.

38

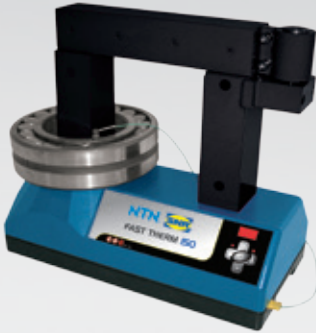

ADVANTAGES

- **Ergonomic:** The standard pivoting arm facilitates the positioning of parts to be heated.
- Voltage/Current **400 V/20 A**.
- Designed for all bearings and rotating parts in a horizontal position with a bore diameter over 30 mm with a maximum outside diameter of **490 mm** and a maximum weight of **150kg**.

Delivered as standard with the core bar for bore diameters of 100 mm or greater.

Five other available yoke sizes are available as an option and may be ordered to suit your particular application.

COMMERCIAL REFERENCE

TOOL FAST THERM 150 / Induction heater

FAST THERM 300

Mobile and powerful induction heater for bearings up to 300 kg.

38



ADVANTAGES

- **Ergonomic:** thanks to its pivoting yoke the parts to be heated can be positioned easily.
- Fitted on a **trolley with a yoke storage shelf**, it can be moved quickly and safely around the various areas of the production floor.
- Voltage/Current **400 V/32 A**.
- Designed for all bearings and rotating parts in a horizontal position with a bore diameter over 30 mm with a maximum outside diameter of **740 mm** and a maximum weight of **300 kg**.

Delivered as standard with the core bar for bore diameters of 115 mm or greater.

Six other available yoke sizes are available as an option and may be ordered to suit your particular application.

COMMERCIAL REFERENCE

TOOL FAST THERM 300 / Induction heater

SAFE THERM 700

Sturdy and very powerful induction heater for very heavy parts up to 700 Kg for a bearing.

Machine typically intended for heavy machine workshops (steel-making, paper, gear manufacturing, naval yards, etc.).

39



ADVANTAGES

- **Ergonomic:**
 - The core bars are positioned vertically and are equipped with a lifting ring,
 - An optional core bar winch simplifies handling,
 - The control screen is directable for operator comfort.
- **Extremely robust:** The design in steel with a glass-fibre coating makes the Safe Therm 700 particularly resistant to impacts and corrosion.
- Parts may be heated **horizontally or vertically**. In the vertical position, the parts rest on support rails (they are not suspended on the fixed core bar).
- Voltage/Current **400 V/63 A**.
- Designed for all bearings and rotating parts in a horizontal position with a bore diameter over 45 mm with a maximum outside diameter of **900 mm** and a maximum weight of **700 kg**.
- Ability to control the heating time to achieve a steady temperature rise and avoid stressing the bearing.
- The device can be started and stopped remotely by means of a remote control, **protecting the operator** from excessive exposure to the magnetic field.

Delivered as standard with the core bar for bore diameters of 145 mm or greater.

Seven other available yoke sizes are available as an option and may be ordered to suit your particular application.

COMMERCIAL REFERENCE

TOOL SAFE THERM 700 / Induction heater

MOUNTING & REMOVAL HOT

SAFE THERM 1200



Extremely powerful induction heater for parts weighing up to 1200 kg.
Indispensable in machine shops in steelworks, paper mills and the rail and wind turbine sectors.

39

ADVANTAGES

• Ergonomic:

- The core bars are positioned vertically and are equipped with a lifting handle,
- A core bar winch is offered as an option,
- The directable control screen provides added comfort for the operator.

• Extremely robust: made of steel with glass-fibre supports to be heated, particularly resistant to impacts and corrosion.

• Parts may be heated **horizontally or vertically**. In the vertical position, the parts rest on support rails (they are not suspended on the fixed horizontal core bar).

• Voltage/Current **400 V/100 A**.

• Designed for all bearings and rotating parts in a horizontal position with a bore diameter over 85 mm with a maximum outside diameter of **1550 mm** and a maximum weight of **1200 kg**.

• Ability to control the heating time to achieve a steady temperature rise and avoid stressing the bearing.

• The device can be started and stopped remotely by means of a remote control, **protecting the operator** from excessive exposure to the magnetic field.

Delivered as standard with the core bar for bore diameters of 215 mm or greater. Three other available yoke sizes are available as an option and may be ordered to suit your particular application.

COMMERCIAL REFERENCE

TOOL SAFE THERM 1200 / Induction heater

ACCESSORIES



A lifting device is offered for use with the Safe Therm 700 and 1200.

39

Delivered as an option with the device and is extremely useful in intensive applications and the handling of heavy core bars.

COMMERCIAL REFERENCE

TOOL FT (Capacity) LIFTING DEVICE

Both the Safe Therm 700 and 1200 can be supplied in a mobile version.

SPECIAL PRODUCTS

NTN-SNR is able to design machines, specially adapted to your application.

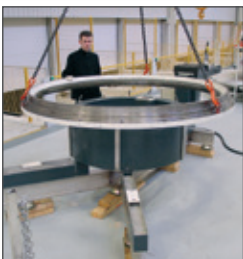

This device, especially developed for a wind turbine application, is capable of heating to 120°C in 60 minutes, parts weighing up to 10 tonnes with an outside diameter of 4 metres.

Thus, the dimensions and performance of our bearing heaters (Fast Therme 150 to Safe Therm 1200) can be modified to match precisely the **geometry** of your parts, your **production patterns** and to the **power supplies** of your workshops.

Customised equipment can also be developed for your large metal parts, such as for wind turbine and railway applications.

We can provide you with a quotation based on the following information:

- The weight of the part to be heated (min/max).
- The dimensions of the part (min/max bore, max. outside diameter, max thickness).
- Electrical power and voltage available.
- Temperature to be achieved.
- Desired heating time or production pattern.

MOUNTING & REMOVAL MECHANICAL

GOOD PRACTICES FOR MECHANICAL DISMOUNTING

Take care when dismantling: look after your equipment and save time, while working safely.

Note, the dismantling of bearings is a delicate operation, both for the operator and for the mechanical items involved.

If mounting requires a lot of know-how, the risks involved in dismantling cannot be ignored, even if the bearing is to be scrapped.

By opting for the correct methods and tools, you reduce the risk of personal injury and damaging parts (shaft, housing, even the bearing, if it is to be re-used).

The two main principles for dismantling are mechanical and hydraulic.

OUR RECOMMENDATIONS FOR MECHANICAL DISMOUNTING

Whenever possible; apply the withdrawal force to the ring with the interference fit.

There are numerous types of extractor, depending on the grip offered by the bearing, its accessibility and the extraction force required.

Extractors equipped with a pump and hydraulic cylinder allow the operator to develop very high extraction efforts, using their own muscular strength. They are easy to use, due to the fact that their arms are self-centering.

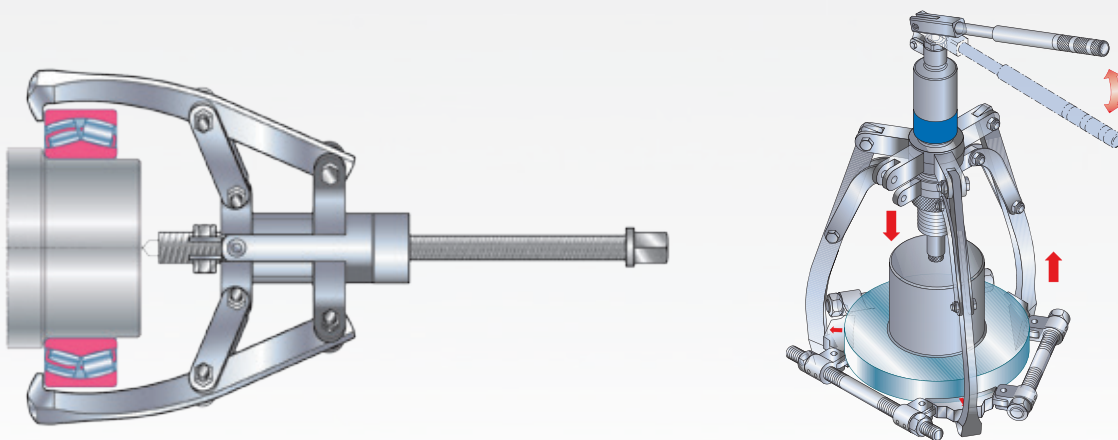

THE PROPER QUESTIONS TO BE ASKED

- How do I grip the part?
Selection of the type of grip: external, internal or special.
- What is the diameter of the part to be extracted?
Enables the span, spread and force to be defined.
- How do I pull on the part?
Choice of a support point: on the central shaft, on the outside of the part or using extraction accessories.

Puller kits for internal gripping of the bore. For quick and easy dismantling of bearings tightly mounted in a housing.



BP Set 5-44



BP Set 45-100



Slide hammer for BP Set 5-44



Clamp

APPLICATIONS

Ideal selection of high-strength extractors with braces for extraction via the bore:

- Bearing whose outer ring is a tight fit in its housing.
- Outer rings or rings with well locked packing.

ADVANTAGES

Practical

- The BP Set 5-44 has a thrust bolt fitted with a handle facilitating the grip for the hand, as well as a slide hammer.
- Each kit contains several pullers that adapt to each of your applications.
- The case for small bearings combines an adjustable counter support and a slide hammer offering you the choice of extraction mode.

Reliable and safe

- The unique design of adjustable puller blocks enables successful and safe dismantling, without risk of jacking over and without forces.
- Each part is made of high quality steel, robust and resistant to impact, ensuring product longevity.

Flexible

- BP Set 5-44 includes 7 pullers for extractions of 5 to 44 mm bore diameters.
- BP Set 45-100 includes 3 pullers for extractions of 45 to 100 mm bore diameters.

COMMERCIAL REFERENCE

TOOL BP Set 5-44 / Bore puller set

TOOL BP Set 45-100 / Bore puller set

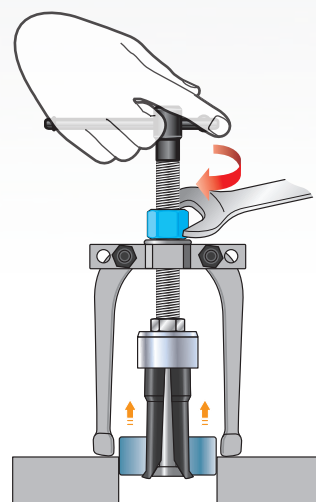

DEEP-GROOVE BALL BEARINGS PULLER KIT

For quick and easy extraction of your deep-groove ball bearings housed in blind bearings.

42



BBPS 10-100



Prong



Extraction ring

APPLICATIONS

This puller kit is specially adapted to carry out, without dismantling your machine, extractions of bearings that are difficult to access, such as:

- Bearings housed in blind bearings,
- Bearings installed on shafts,
- Bearings with a tight fit on outer or inner rings.

ADVANTAGES

Practical and easy

- The kit contains 3 O-rings to facilitate the assembly of your tool.
- The marking of parts along with the selection table included enables a quick selection of accessories to be used.
- The visual user guide favours the correct implementation of the tool.

Reliable and safe

- The design of tools enables successful and safe dismantling, without risk of jacking over and without forces.
- Each component is made of high quality steel, robust and resistant to impact, ensuring product longevity.

Flexible

- The case includes 3 different sizes of shafts and 28 puller arms providing a very wide range of applications.
- The kit enables extraction of bearings of 10 to 100 mm bore diameter.

COMMERCIAL REFERENCE

TOOL BBPS 10-100 / Ball bearing puller set



2/3 PRONGS SELF-CENTERING MECHANICAL PULLER

43

A simple, robust and efficient range of pullers for an easy and safe dismounting of small or medium size bearings.



SCMP - 3 arms



SCMP - 2 arms



APPLICATIONS

Is also well suited to removing pulleys, toothed wheels, flywheels fixed to a shaft.

ADVANTAGES

Practical

- The self-centering mechanism ensures the simultaneous positioning of the puller's arms on the bearing.
- Compact and ergonomic, it may be easily operated in every position by one person.

Safe

- Self-locking system prevents the arms from bending or slipping.
- The greater the extraction force, the tighter the jaws grip the part.
- Robust, designed in hardened steel for maximum strength.

Multiple uses

- Quickly convertible to two or three claws, depending on the space available.
- Three available models for selection according to the outside diameter of the parts to be extracted and the required reach.

Maximum spread (mm)	Maximum span (mm)	Capacity (tons)
120	80	2
180	120	3
270	160	5

COMMERCIAL REFERENCE

TOOL SCMP 2/3-120 / Self-center mech puller

TOOL SCMP 2/3-180 / Self-center mech puller

TOOL SCMP 2/3-270 / Self-center mech puller

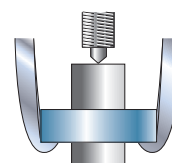
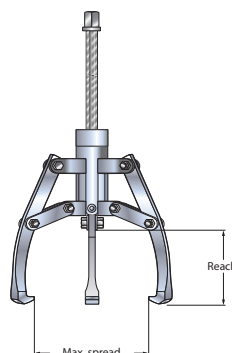

2/3 PRONGS SELF-CENTERING HYDRAULIC PULLER

43

A range of powerful tools for very easy and risk-free dismantling of large bearings and press fitted parts such as pulleys and toothed wheels.

APPLICATIONS

The self-centering device facilitates positioning and anchoring around the bearing. The power developed by the hydraulic system allows the part to be extracted safely with very little effort.

ADVANTAGES

Practical

- Ready-to-use in a strong case. No assembly of the jaws required before use.
- Compact: the hydraulic pump is built-in. No need for a separate pump, hose or spindle.
- Ergonomic: pump handle pivoting through 360°, allowing the extractor to be used in the most comfortable position. Telescopic, it provides optimum transmission of the effort.
- Easy centering of the piston on the shaft with retractable, integrated point.
- A piston extension is supplied for use with a remote support surface.
- A piston return device makes it ready immediately for further use.
- Long stroke of hydraulic spindle facilitates dismantling in one operation.

Multiple uses

- Possibility to change between two or three jaws, depending on the accessibility of the bearing.
- Available in three versions, depending on the power and size required: 4, 12, 20 and 30 tons.

Capacity (tonnes)	Maximum spread (mm)	Maximum span (mm)	Cylinder stroke (mm)
4	325	190	60
12	485	305	85
20	570	365	111
30	680	465	111

- For the 4 and 12-tonne capacity, an accessory kit consisting of a puller block, connecting rods and a set of bearings separators increases the number of uses and makes separation easier.

Safe

- A safety relief valve prevents any risk of overloading and limits the force applied to the maximum capacity of the equipment.
- A cover protects the user from possible flying bearing fragments. Made of transparent material, it provides good visibility for controlling the extraction.
- The 20 and 30 ton model is equipped with an innovative two-stage pump which makes operation easier and safer.

COMMERCIAL REFERENCE

TOOL SCHK 4 TONS / Self-center hyd puller
 TOOL SCHK 12 TONS / Self-center hyd puller
 TOOL SCHK 20 TONS / Self-center hyd puller
 TOOL SCHK 30 TONS / Self-center hyd puller



SCHK 4T - 3 arms



SCHK 4T - 2 arms

ACCESSORY CASES FOR 4 AND 12-TON SCHP

A strong grip for a safe and easy dismounting.

44



AS-SCHP 12T

APPLICATIONS

A separator is a complementary tool to a claw extractor when the latter does not have sufficient grip. A perfect grip on the back of parts, using bevelled blades, reduces the force necessary for dismounting and avoids damaging the shaft's contact surface

ADVANTAGES

- Robust design ensuring a long life for the separation blades.
- After separation by tightening the two blades, turning the separator enables greater force to be used without deforming the blades for the complete extraction of the part.
- Extensions are included to compensate for the distance of the support face.
- Easy centering of the piston on the shaft with integrated point.
- Two versions are available depending on the required power: 4 and 12 tons.

COMMERCIAL REFERENCE

TOOL AS-SCHP 4T / acc set hyd puller
TOOL AS-SCHP 12T / acc set hyd puller



AS-SCHP 4T

UNIVERSAL, TRI-SECTION PULLING PLATE

A strong grip for safe and effective dismounting using a mechanical or hydraulic puller.

▶ 44



APPLICATIONS

The tri-section pulling plate is the complementary tool to the three-armed pullers when the latter does not have sufficient grip. Universal, it is suitable for both the SCHK hydraulic extractor and the SCMP mechanical model.

ADVANTAGES

- The blades are placed behind the bearing, where the extraction force is most effective.
- The application of the effort on the inner ring minimises the risk of damaging the bearing while preserving the rolling body and the outer ring.
- The tri-section construction distributes the extraction force evenly, preventing the bearing from locking and/or tilting on the shaft during dismounting.

COMMERCIAL REFERENCE

TOOL BP3S 26-160 / Tri-section back puller
TOOL BP3S 50-210 / Tri-section back puller
TOOL BP3S 90-340 / Tri-section back puller
TOOL BP3S 140-495 / Tri-section back puller



PULLER-SEPARATOR KIT

45

For easy and risk-free removal of rings or complete bearings mounted on a shaft and difficult to grasp.

Adjustable arms, provided in the kit, also enable extractions by internal or external gripping.



APPLICATIONS

Allows the extraction of all parts mounted onto a shaft by force, such as pulleys, handwheels and pinions.

In order to adapt to your various applications, the adjustable arms will also enable you to dismount:

- Bearings or rings mounted on the shaft (external gripping),
- Bearings or rings jammed in a housing (internal gripping).

ADVANTAGES

2-in-1 tool

- Each case contains a puller block that allows the mounting of the tool for separations as well as extractions.
- The removable arms will allow you to carry out extractions by internal or external gripping.
- A separator for your parts installed on the shaft, as well as a set of removable arms for internal or external gripping, all contained in a single case.

Powerful and reliable

- The separator is equipped with bevelled blades that ensure excellent grip and thereby avoid any locking.
- With a power of 100 kN, BPES guarantees safe extractions without any degradation to your environment.
- The separator as well as the puller are made of very high quality steel, ensuring the resistance and longevity of your kit.

Practical

- Thanks to its unique design, BPES 10-105 covers a wide range of applications.
- The kit contains 2 extensions for applications requiring a long span.

COMMERCIAL REFERENCE

TOOL BPES 10-105/Back puller extract set



Extraction with separator



External grasping extraction

HYDRAULIC PULLER FOR MOUNTING AND DISMOUNTING

Practical and safe 3-in-1 tool, for mounting and dismounting of bearings and sleeves by internal or external grasping.

45



APPLICATIONS

Ideal tool for mounting and dismounting a large variety of mounting parts, including bushings, bearings, wheels, gears and pulleys.

The kit, supplied in a steel case, includes:

- An internal gripping puller
- A double-acting hydraulic cylinder: 8 tons for thrust and 12 tons for extraction,
- 3 arms as well as 3 extensions.

ADVANTAGES

Quick and practical

- 3-in-1 tool for a reduced preparation time: same tool used for mounting and dismounting of bearings.
- The single double-acting cylinder ensures a thrust force of 8 tons as well as an extraction of 12 tons.
- Included extensions can be used to attain a greater range.

Longevity

- A built-in safety valve enables the tool to operate below rated pressure in order to preserve it over time.

Safety

- The built-in safety valve prevents all injuries to the user and all damage to the working environment.
- A self-centering design avoids risk of slipping of the arm during the extraction operation by internal gripping.

COMMERCIAL REFERENCE

TOOL PUSH/PULLER 8/12 Tons



Internal gripping



Extraction



Thrust

MOUNTING & REMOVAL HYDRAULIC

THE GOOD PRACTICES FOR HYDRAULIC MOUNTING AND DISMOUNTING

HYDRAULIC MOUNTING

The mounting of large bearings with tapered bores requires considerable effort that is difficult to produce by mechanical screw tightening. The use of hydraulic technology is required in such cases.

A preliminary solution consists in injecting a oil film over the entire contact area between the shaft and the inner ring. Another solution consists in using a hydraulic nut to develop the necessary mounting force. The two principles may also be used simultaneously to make mounting easier. The residual clearance is checked using feeler gauges or a dial gauge is used to measure the displacement of the bearing along the tapered seat.

Two types of mounting lend themselves to this method:

TAPERED SEAT SHAFT

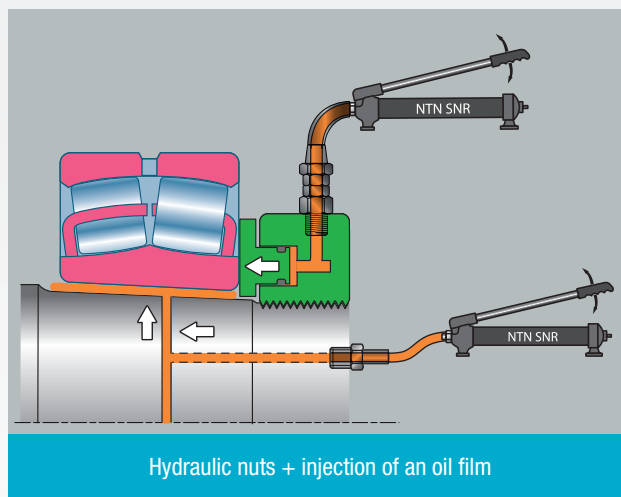
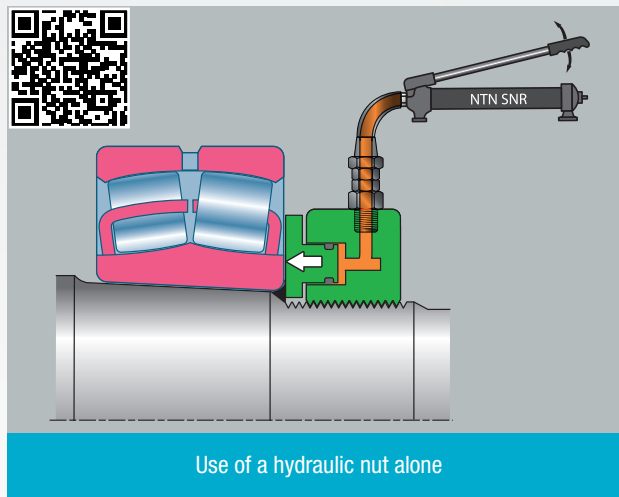

SHAFTS WITH A CYLINDRICAL CONTACT SURFACE IN ASSOCIATION WITH A SLEEVE

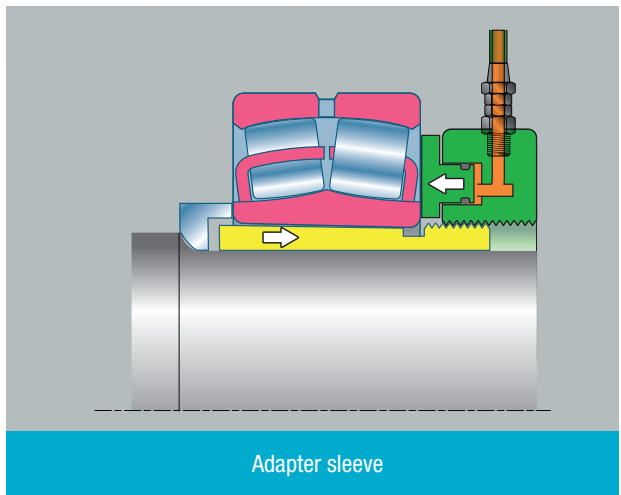
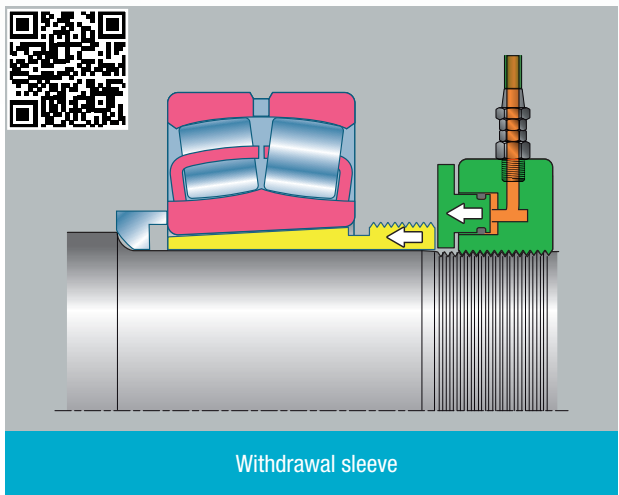

HYDRAULIC DISMOUNTING

- ▶ If an adapter or withdrawal sleeve was used during mounting, a hydraulic nut can be used for quick and effortless dismounting.
- ▶ If hydraulic channels were originally provided in the shaft, the injection of a film of oil on the contact surface between the shaft and the inner ring greatly reduces the effort required.

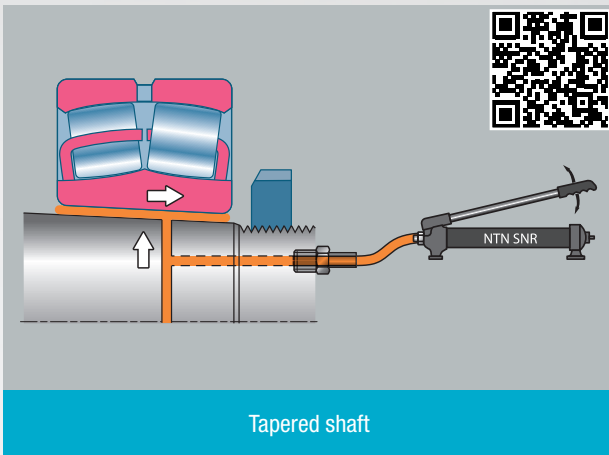

Tapered shaft

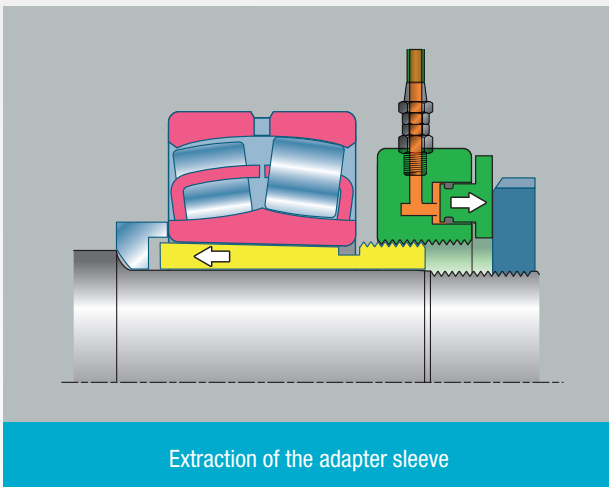

Extraction of the adapter sleeve

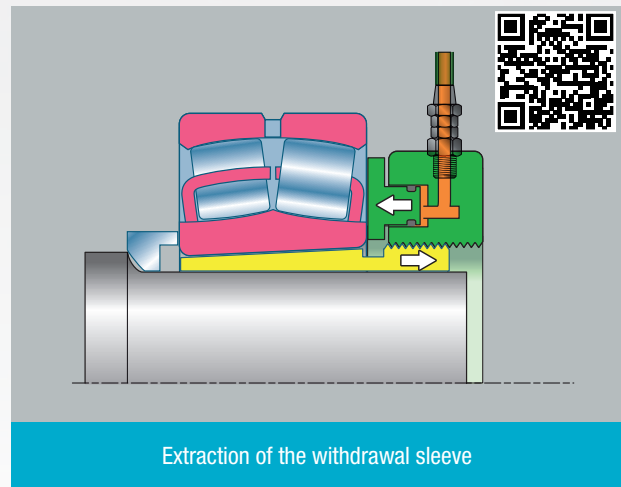

Extraction of the withdrawal sleeve



Extraction of the adapter sleeve with a hydraulic nut



Extraction of the withdrawal sleeve with a hydraulic nut

Precise, effortless mounting of your large bearings with a tool that is always ready for use.

APPLICATIONS

Beyond a certain shaft diameter, the mounting or dismounting of a bearing on tapered seatings requires hydraulic assistance.

A hydraulic nut ensures perfect control of the adjustment of the assembly while limiting the use of manual force and reducing the time taken for the operation.

ADVANTAGES

Besides the hydraulic principle, the **“back and forth”** design provides unique ease of operation with the automatic return of the thrust plate to its initial position (**design patented by NTN-SNR**)

“No need to retract the piston manually. This operation is often tedious and subject to oil leaks: the NTN-SNR nut is automatically ready for a new use.”

- Wide range of sizes: for shafts from 50 mm to 1000 mm in diameter.
- Range also available in standard inch dimensions HMVC from 1,967 to 37,410 inches.
- Special sizes on request.
- Set of spare piston seals supplied as standard.
- The hydraulic nut is equipped with:
 - Two hydraulic connection points, with spot facing for perfect sealing,
 - One quick coupling connection (male) which can be positioned on the front face or on the outside diameter, depending on the ease of access.
(The 1500 bar high pressure provides maximum safety with a locking stop),
 - One 1500 bar ball valve,
 - 2 holes on the front face are provided for mounting the dial gauge (not included).
- The surface treatment of the nuts provides excellent protection against corrosion and ensures a long working life.
- Easier handling and nut screwing due to:
 - The knurling of the outer surface (all sizes),
 - A bar being supplied and the provision of 4 holes on the outer diameter.
(For sizes \geq HMV 50 EBF).
- Easy handling with eye bolts for nut sizes HMV 60 EBF and upwards supplied.

COMMERCIAL REFERENCE

TOOL HMV (size) EBF / Hydraulic nut (metric)

TOOL HMVC (size) EBF / Hydraulic nut (inches)

OPTIONAL ACCESSORIES

- Dial gauge for the measurement of the displacement of the piston from 5 to 10mm

COMMERCIAL REFERENCE

- TOOL DIAL GAUGE 50
- TOOL DIAL GAUGE 100

- Adaptor kit for the dial gauge

COMMERCIAL REFERENCE

- TOOL DIAL EXTENSION SET



Tool Dial gauge 50



Tool Dial extension set



MANUAL HYDRAULIC PUMP KITS

50

An ultralight high pressure 2-stage hand pump 700 bar (70 MPa) and 1500 bar (150 MPa).



TOOL PUMP SET 700B

APPLICATIONS

These high-pressure pumps are designed for use with automatic return hydraulic nuts or for the mounting and dismounting of bearings coated with an oil film.

Pumps are supplied as standard with the following accessories designed for use at 700 bar and 1500 bar:

- 1 pressure gauge, minimising the risk of overloading,
- 1 high-quality hose (1.5 m for the 700 bar pump with a 0.3 litre reservoir, 3m for the 700 and 1500 bar pumps with a 0.9 litre reservoir),
- 1 quick coupling connection (female) suitable for NTN-SNR hydraulic nuts,
- They are supplied filled with hydraulic oil.

ADVANTAGES

- Ultra-light, compact design.
- Robust reservoir in composite materials.
- Ergonomic: locking of the lever to facilitate transport
- Robust: pump guaranteed for life under normal conditions of use.
- Efficient: savings in time and effort due to the two stages which allow a reduction of 80% in the number of pump strokes required in comparison with single-stage pumps.
- User safety: electrically isolated lever and safety relief valve.
- Multiple uses: 3 available reservoir sizes:
 - 0.3 litre for nuts \leq HMV 54 EBF,
 - 0.9 litre for nuts \leq HMV 92 EBF,
 - 2.5 litres for nuts \leq HMV 200 EBF (for 1500 bar pump).

Accessories included for 700 and 1500 bar pumps

- Pressure gauge adaptor for pumps 750b 0.3L and 0.9L.
- Pressure gauge (0-700 bar) or (0-1500 bar)
 - Liquid filled to protect against any sudden loss of pressure,
 - Dual markings in bars / PSI,
 - Fitted with a device protecting against bursting.
- Hose 700 and 1500 bar
 - Very strong thermoplastic, reinforced with layers of woven steel wire,
 - Polyurethane envelope for extreme abrasion resistance,
 - With a rubber protective "handle".
- Quick coupling protection (female) 1500 bars, which provides maximum safety with end stop locking and optimum sealing with a flat face valve.

Technical characteristics of the hydraulic oil

Contains corrosion inhibitors which do not attack sealing materials such as nitrile.

Relative density at 15°C: 0.870 kg/dm³

Viscosity at 40°C: 31 cSt

Viscosity index: 102

Flash point: 230°C

Freezing point: -36°C

COMMERCIAL REFERENCE

TOOL PUMP SET 700B - (reservoir capacity) I / Pump with accessories

TOOL PUMP SET 1500B - 2.5 L / Pump with accessories

TOOL HYDRAULIC OIL 1 L



TOOL HYDRAULIC OIL 1L

EXTENSION TUBES AND THEIR ADAPTORS



Pipe

In order to allow pressurised oil injection into a sleeve or a shaft with a thick wall, NTN-SNR proposes a range of extension tubes with adaptors, thus enabling to facilitate the extraction of a bearing.

- Maximum pressure = 1500b for greater safety.
- Stainless steel tubes for very high resistance.



Adaptor

Pipe

Several sizes available. It can be connected directly to the sleeve.

Adaptor

To be selected according to the extension tube diameter. It enables to connect the tube to the hydraulic connection (not supplied with the adaptor).

Connection

It is screwed onto the adaptor (G1/4) and can be directly used with our pump kits, TOOL PUMP set 700b and 1500b.



Connection

Sizes and references

Sleeve threading	Pipe	Adaptor	Connection
M4 (diagram 1)	TOOL EXTENSION PIPE M4 50 MPA	TOOL CONNECTING NIPPLE M4 150 MPA	TOOL HMV NIPPLE 1/4
M6 (diagram 2)	TOOL EXTENSION PIPE M6 150 MPA	TOOL CONNECTING NIPPLE M6 150 MPA	
G 1/8 (diagram 3)	TOOL EXTENSION PIPE G1/8 150 MPA	TOOL CONNECTING NIPPLE G1/8 150 MPA	
G 1/4 (diagram 4)	TOOL EXTENSION PIPE G1/4 150 MPA	TOOL CONNECTING NIPPLE G1/4 150 MPA	

(diagram 1)

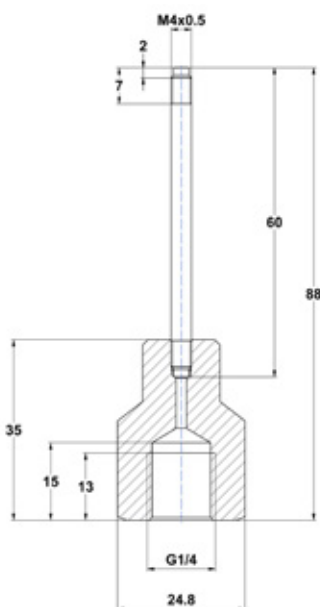

(diagram 2)

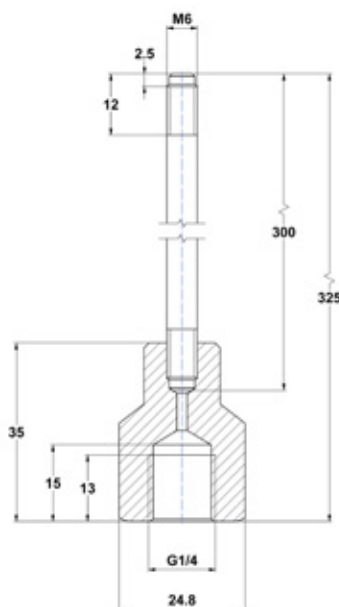

(diagram 3)



(diagram 4)

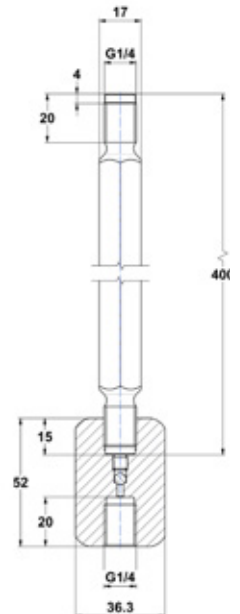



CONTENTS

SAFETY & MEASUREMENT

P. 32 SAFETY INSTRUMENT

- Heat-resistant gloves 32

P. 32 MEASUREMENT INSTRUMENTS

- Set of calibrated feeler gauges 32
- Infra-red thermometer with laser targeting 33

SAFETY & MEASUREMENT

SAFETY INSTRUMENT

HEAT-RESISTANT GLOVES

Protective gloves to safely handle oily and hot parts of up to + 350° C

52



ADVANTAGES

- Made of KEVLAR, they are extremely resistant to tearing, abrasion and cuts.
- Non-inflammable: they provide a high level of protection against contact and convective heat.
- They are tested and certified for mechanical (EN 388) and thermal (EN407) hazards.
- Non-fluffy, they avoid polluting the bearings.
- Extremely comfortable, they are useful for all maintenance work.
- Single size: 10.5.

COMMERCIAL REFERENCE

TOOL GLOVE HEAT RESISTANT

MEASUREMENT INSTRUMENTS

SET OF CALIBRATED FEELER GAUGES

A simple and precise tool for measuring the clearance between two parts.

52



APPLICATIONS

This feeler gauge set allows the quick, accurate measurement of radial clearance, especially on spherical roller and cylindrical bearings. It contains 17 gauges.

3 versions of the gauge set are offered: 100mm, 150mm and 300 mm long

ADVANTAGES

- Set of 17 round end gauges.
- Delivered with a spare set of the thinnest gauge blades.
- Available in 100 mm, 150 mm and 300 mm.
- In a protective steel sleeve.
- Calibrated to 1/100th.

COMMERCIAL REFERENCE

FEELER GAUGE TOOL (gauge length)

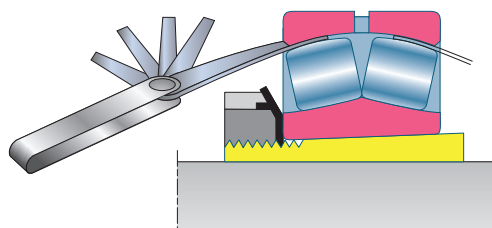

LASER TEMP 301 INFRA-RED THERMOMETER WITH LASER TARGETING

53



Enabling a preliminary diagnosis of the machine operation by means of accurate and safe measurement of the temperature remotely or by contact.

APPLICATIONS

The LASER TEMP 301 thermometer combines safety with accuracy.

- The safety of remote infrared measurement for burning, moving or difficult-to-access objects.
- Accurate measurement using the contact probe.

Its elaborate optical system allows small, remote targets to be measured easily and precisely.

ADVANTAGES

- Wide measurement range in infrared mode: -50°C to $+850^{\circ}\text{C}$.
- High degree of precision, using the:
 - Laser targeting device,
 - The excellent 30:1 distance:target ratio,
 - Emissivity adjustable between 0.1 and 1,
 - Type K thermocouple wire probe.
- Extremely quick measurements: response time less than 1 second.
- Internal memory able to record up to 20 measurements.
- Equipped with the following functions:
 - High / low, visual and audible adjustable alarms,
 - Automatic switch-off to maximise its useful life,
 - Maximum, minimum, difference, average measurement.
- Light, ergonomic gun shape.
- Simple to use, it may be easily configured to work in $^{\circ}\text{C}$ or $^{\circ}\text{F}$.
- Back-lit display for easy reading.

Supplied with:

- Type K thermocouple wire probe (range -50°C to $+440^{\circ}\text{C}$, length 1 m),
- Protective pouch - User manual.

COMMERCIAL REFERENCE

TOOL LASERTEMP 301 / IR Thermometer

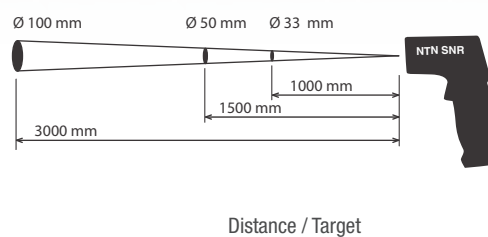
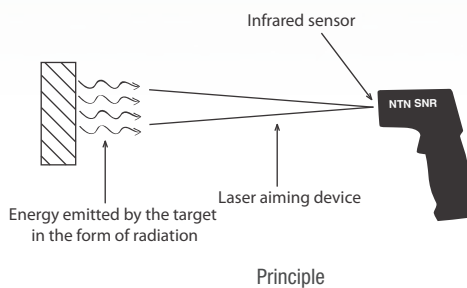



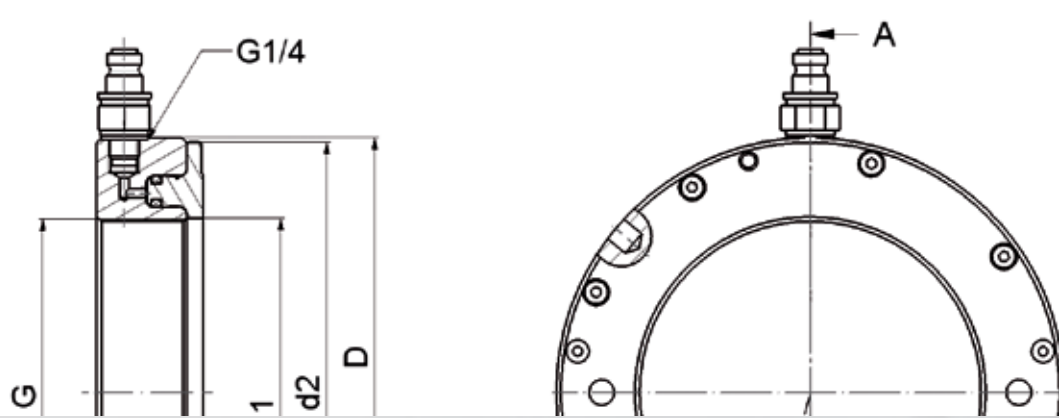

CONTENTS

TECHNICAL DATA

• Mounting tool kit case	36
• Anti-fretting paste	36
• Adjustable spanners	36
• Heating equipment	38
• Bore puller kits	41
• Deep-groove ball bearings extractor kit	42
• Self-centering mechanical puller	43
• Self-centering hydraulic puller	43
• Accessory cases	44
• Tri-section pulling plate	44
• Puller - separator kit	45
• Hydraulic puller for mounting and dismounting	45
• Hydraulic nuts	46
• Manual hydraulic pump kits	50
• Heat-resistant gloves	52
• Set of calibrated feeler gauges	52
• Infra-red thermometer with laser targeting	53

TECHNICAL DATA

COLD MOUNTING TOOL KIT CASE

► P 9

Reference	TOOL IFT SET 33 / Industry Fitting Tool Set
Description	Mounting tool kit
Application	Cold mounting of bearings: bore Ø: 10 to 50 mm outside Ø: 26 to 110 mm
Contents	33 Impact rings 3 Mounting sleeves 1 Dead-blow mallet (weight 0.7 kg)
Material	Socket machined from strong, solid material
Case dimensions	430 x 320 x 100 mm
Weight of kit, including case	4.8 kg

ANTI-FRETTING PASTE B 750G / T 60G

► P 11

References	LUB ANTI FRETTING PASTE
Density	1.23
Colour	Whitish
Texture	Smooth
Base oil	Synthetic
Nature of thickener	Lithium soap
NLGI consistency	1
Temperature range for use	-40°C to +150°C
Viscosity of the base oil at 40°C,	350 mm ² /s
Flash point	> 200°C
Drop point DIN ISO 2176	> 185°C
Packaging	Tube 60 g - box 750 g

ADJUSTABLE SPANNERS

► P 11

Reference	TOOL PS (size) / Pin spanner	
Description	Articulated manual pin spanner	
Material	Hardened, forged chrome vanadium steel. Satin chrome finish	
Pin hardness	40 HRC	
Use	Tommy nuts (examples of accuracy: TB, TBR, TBP, TBPR, etc.)	
References	Nut diameter (mm)	Pin diameter (mm)
TOOL PS 15-35	15-35	3
TOOL PS 35-50	35-50	4
TOOL PS 50-80	50-80	5
TOOL PS 80-120	80-120	6
TOOL PS 120-180	120-180	8

References	TOOL HS (size) / Hook spanner	
Description	Articulated manual hook spanner	
Material	Hardened, forged chrome vanadium steel. Satin chrome finish	
Use	Slot nuts (e.g.: KM, KML, ..., B, BR, BP, ...)	
References	Nut diameter (mm)	
TOOL HS 15-35	15-35	
TOOL HS 35-50	35-50	
TOOL HS 50-80	50-80	
TOOL HS 80-120	80-120	
TOOL HS 120-180	120-180	

PRECISION NUT CROSS REFERENCE/tommy nut and slot nut spanners										
Spanner 15-35 (mm)		Spanner 35-50 (mm)		Spanner 50-80 (mm)		Spanner 80-120 (mm)		Spanner 120-180 (mm)		
Hook	Pin	Hook	Pin	Hook	Pin	Hook	Pin	Hook	Pin	
B and TB nuts	B 20/1	B 20/1	B 25	TB 25	B 35	TB 35	B 60	TB 60	B 90	TB 90
	TB 90	B 20/1.5	B 30	TB 30	B 40	TB 40	B 65	TB 65	B 95	TB 95
	-	-	-	-	B 45	TB 45	B 70	TB 70	B 100	TB 100
	-	-	-	-	B 50	TB 50	B 75	TB 75	-	-
	-	-	-	-	B 55	TB 55	B 80	TB 80	-	-
	-	-	-	-	B 60	TB 60	B 85	TB 85	-	-
	-	-	-	-	-	-	B 90	TB 90	-	-
BP and TBP nuts	-	-	BP 20/1	TBP 20/1	BP 30	TBP 30	BP 55	TBP 55	BP 75	TBP 75
	-	-	BP 20/1.5	TBP 20/1.5	BP 35	TBP 35	BP 60	TBP 60	BP 80	TBP 80
	-	-	BP 25	TBP 25	BP 40	TBP 40	BP 65	TBP 65	BP 85	TBP 85
	-	-	-	-	BP 45	TBP 45	BP 70	TBP 70	BP 90	TBP 90
	-	-	-	-	BP 50	TBP 50	-	-	BP 95	TBP 95
	-	-	-	-	-	-	-	-	BP 100	TBP 100
BR and TBR nuts	-	-	BR 25	TBR 25	BR 35	TBR 35	BR 60	TBR 60	BR 90	TBR 90
	-	-	BR 30	TBR 30	BR 40	TBR 40	BR 65	TBR 65	BR 95	TBR 95
	-	-	-	-	BR 45	TBR 45	BR 70	TBR 70	BR 100	TBR 100
	-	-	-	-	BR 50	TBR 50	BR 75	TBR 75	-	-
	-	-	-	-	BR 55	TBR 55	BR 80	TBR 80	-	-
	-	-	-	-	BR 60	TBR 60	BR 85	TBR 85	-	-
	-	-	-	-	-	-	BR 90	TBR 90	-	-
BPR and TBPR nuts	-	-	BPR 20/1	TBPR 20/1	BPR 30	TBPR 30	BPR 55	TBPR 55	BPR 75	TBPR 75
	-	-	BPR 20/1.5	TBPR 20/1.5	BPR 35	TBPR 35	BPR 60	TBPR 60	BPR 80	TBPR 80
	-	-	BPR 25	TBPR 25	BPR 40	TBPR 40	BPR 65	TBPR 65	BPR 85	TBPR 85
	-	-	-	-	BPR 45	TBPR 45	BPR 70	TBPR 70	BPR 90	TBPR 90
	-	-	-	-	BPR 50	TBPR 50	-	-	BPR 95	TBPR 95
	-	-	-	-	-	-	-	-	BPR 100	TBPR 100

KM NUT CROSS REFERENCE/pin tightening spanner				
Spanner 15-35 (mm)	Spanner 35-50 (mm)	Spanner 50-80 (mm)	Spanner 80-120 (mm)	Spanner 120-180 (mm)
TOOL HS 15-35	TOOL HS 35-50	TOOL HS 50-80	TOOL HS 80-120	TOOL HS 120-180
KM 0	KM 5	KM 7	KM 12	KM 18
KM 1	KM 6	KM 8	KM 13	KM 19
KM 2	-	KM 9	KM 14	KM 20
KM 3	-	KM 10	KM 15	KM 21
KM 4	-	KM 11	KM 16	KM 22
-	-	KM 12	KM 17	KM 23
-	-	-	KM 18	KML 24
-	-	-	-	KM 24
-	-	-	-	KM 25
-	-	-	-	KML 26
-	-	-	-	KML 27
-	-	-	-	KML 28
-	-	-	-	KML 28
-	-	-	-	-

TECHNICAL DATA

HEATING APPARATUS - TOOL FAST THERM (SIZE) / INDUCTION HEATER					> P 14/15
TECHNICAL DATA	FAST THERM 20	FAST THERM 35	FAST THERM 150	FAST THERM 300	
ELECTRICITY					
Maximum power consumption	3,6 kVA	3,6 kVA	12,8 kVA	12,8 kVA	
Maximum voltage/current	230 V / 16 A	230 V / 16 A	400 V / 32 A	400 V / 32 A	
Frequency	50 Hz	50 Hz	50 Hz	50 Hz	
Other voltages on request	110 V to 240 V	110 V to 240 V	230 V / 500 V / 560 V	230 V / 500 V / 560 V	
Other frequencies on request	60 Hz	60 Hz	60 Hz	60 Hz	
CONTROL					
Temperature adjustment	+ 40°C to + 240°C	+ 40°C to + 240°C	+ 40°C to + 240°C	+ 40°C to + 240°C	
Heating time adjustment Maximum temperature	no -	0-99 min. + 240°C	0-99 min. + 240°C	0-99 min. ● + 240°C ○ + 400 °C	
Temperature probe Reference: TOOL +	● TEMP PROBE 400 (+)	● TEMP PROBE 1000 (+)	● TEMP PROBE 1000 (+)	● TEMP PROBE 1000 (+)	
Temperature control precision	+/- 2°C	+/- 2°C	+/- 2°C	+/- 2°C	
Temperature holding at the end of cycle	●	●	●	●	
Demagnetising	Automatic	Automatic	Automatic	Automatic	
Residual magnetism	< 2 A / cm	< 2 A / cm	< 2 A / cm	< 2 A / cm	
Audible signal	●	●	●	●	
APPLIANCE DESIGN					
Dimensions (L x W x H) (mm)	345 x 200 x 240	420 x 260 x 360	505 x 260 x 440	1060 x 500 x 1090	
Space between pivots A and B ⁽¹⁾	120 x 100 mm	180 x 180 mm	210 x 200 mm	330 x 260 mm	
Weight (without yoke)	17 kg	35 kg	54 kg	146 kg (trolley included)	
Pivoting arm	no	●	●	●	
Shelf trolley	no	no	no	●	
PARTS TO BE HEATED					
Maximum weight ⁽⁺⁺⁾	40 kg	70 kg	150 kg (horizontal)	300 kg (horizontal)	
Minimum bore diameter (")	10 mm	15 mm	30 mm	30 mm	
Maximum external diameter	280 mm	410 mm	490 mm	740 mm	
Maximum width	120 mm	180 mm	210 mm	330 mm	
STANDARD AND OPTIONAL EQUIPMENT					
Bearing bore $\varnothing \geq$	References: TOOL ⁽⁺⁺⁺⁾				
10 mm	○ FT20-YOKE 10				
15 mm	○ FT20-YOKE 15	○ FT35-YOKE 15			
20 mm	● FT20-YOKE 20	○ FT35-YOKE 20			
30 mm			○ FT150-YOKE 30	○ FT300-YOKE 30	
35 mm	● FT20-YOKE 35	○ FT35-YOKE 35			
45 mm			○ FT150-YOKE 45	○ FT300-YOKE 45	
60 mm	● FT20-YOKE 60	○ FT35-YOKE 60	○ FT150-YOKE 60	○ FT300-YOKE 60	
70 mm		● FT35-YOKE 70	○ FT150-YOKE 70	○ FT300-YOKE 70	
85 mm			○ FT150-YOKE 85	○ FT300-YOKE 85	
100 mm			● FT150-YOKE 100	○ FT300-YOKE 100	
115 mm				● FT300-YOKE 115	

● Standard / ○ Optional equipment
 (+) with min. yoke size / (+++) example: TOOL FT 35-YOKE 20
 (+): length of probe wire (e.g. 400: 400 = 400 mm)
 (++): for bearings. For other parts, please contact us.

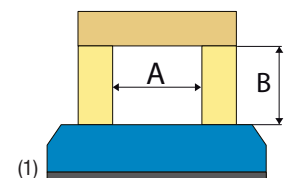

HEATING APPARATUS - TOOL SAFE THERM (size) / Induction Heater
> P 15/16

TECHNICAL DATA	SAFE THERM 700	SAFE THERM 1200
ELECTRICITY		
Maximum power consumption	25 kVA	40 kVA
Maximum voltage/current	400 V / 63 A	400 V / 100 A
Frequency	50 Hz	50 Hz
Other voltages on request	230 V/ 500 V/ 560 V	230 V/ 500 V/ 560 V
Other frequencies on request	60 Hz	60 Hz
CONTROL		
Temperature adjustment	+40°C to + 240°C	+40°C to + 240°C
Heating time adjustment Maximum temperature	0-99 min. ● + 240°C ○ + 400 °C	0-99 min. ● + 240°C ○ + 400 °C
Temperature probe Reference: TOOL +	● TEMP PROBE 1000 (+)	● TEMP PROBE 1500 (+)
Temperature control precision	+/- 2°C	+/- 2°C
Temperature holding at the end of cycle	●	●
Demagnetising	Automatic	Automatic
Residual magnetism	< 2 A / cm	< 2 A / cm
Audible signal	●	●
APPLIANCE DESIGN		
Dimensions (L x W x H) mm	780 x 1200 x 1060 (**)	1200 x 1700 x 1250 (**)
Space between pivots A and B ⁽²⁾	390 x 430 mm (**)	680 x 470 mm (**)
Weight (vertical yoke)	320 kg	850 kg
Pivoting arm	No (Vertical bar)	No (Vertical bar)
Bar lifting device Reference: TOOL +	○ FT600-Lifting Device	○ FT1200-Lifting Device
PARTS TO BE HEATED		
Maximum weight ⁽⁺⁺⁾	700 kg (horizontal)	1200 kg (horizontal)
Minimum bore diameter ⁽⁺⁾	45 mm	85 mm
Maximum external diameter	900 mm (**)	1550 mm (**)
Maximum width	410 mm (**)	440 mm (**)
STANDARD AND OPTIONAL EQUIPMENT		
Bearing bore Ø ≥	References: TOOL ^(***)	
20 mm		
30 mm		
35 mm		
45 mm	○ ST700-YOKE 45	
60 mm	○ ST700-YOKE 60	
70 mm	○ ST700-YOKE 70	
85 mm	○ ST700-YOKE 85	○ ST1200-YOKE 85
100 mm	○ ST700-YOKE 100	
115 mm	○ ST700-YOKE 115	○ ST1200-YOKE 115
130 mm	○ ST700-YOKE 130	
145 mm	● ST700-YOKE 145	○ ST1200-YOKE 145
215 mm		● ST1200-YOKE 215

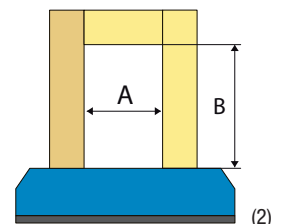

(2)

● Standard / ○ Optional equipment

(*) with min. yoke size/ (**) other dimensions upon request

(***) example: TOOL FT 35-YOKE 20

(+): length of probe wire (e.g. 400: 400 = 400 mm)

(++): for bearings. For other parts, please contact us.

TECHNICAL DATA

DIMENSIONS (MM) AND WEIGHT (KG) OF BARS						► P 14 - 16
	FT20	FT35	FT150	FT300	ST700	ST1200
Y10	7x7x200 0.08 Kg					
Y15	10x10x200 0.15 Kg	10x10x280 0.2 Kg				
Y20	14x14x200 0.3 kg	14x14x280 0.4 kg				
Y30			20x20x350 1.1 kg	20x20x490 1.5 kg		
Y35	25x25x200 0.9 kg	25x25x280 1.3 kg				
Y45			30x30x350 2.4 kg	30x30x490 3.3 kg	30x30x700 4.7 kg	
Y60	40x40x200 2.5 kg	40x40x280 3.4 kg	40x40x350 4.2 kg	40x40x490 5.9 kg	40x40x700 8.4 kg	
Y70		50x50x280 5.3 kg	50x50x350 6.6 kg	50x50x490 9.2kg	50x50x700 13.8 kg	
Y85			60x60x350 9.4 kg	60x60x490 13.2 kg	60x60x700 19.5 kg	60x60x850 24 kg
Y100			70x70x350 12.8 kg	70x70x490 18 kg	70x70x700 26.9 kg	
Y115				80x80x490 23.5 kg	80x80x700 35 kg	80x80x850 42.7 kg
Y130					90x90x700 44.5 kg	
Y145					100x100x700 55 kg	100x100x850 66.8 kg
Y215						150x150x850 150 kg

BORE PULLER KITS (with internal grasping)
> P 18

Reference	TOOL BP SET (size) / Bore Puller	
Contents	BP Set 5-44 7 clamps 1 against adjustable support 1 slide hammer	BP Set 45-100 3 clamps 1 against adjustable support
Bore diameter (mm)	5 to 44	45 to 100
Case dimensions (mm)	405 x 345 x 100	490 x 500 x 130
Case weight (kg)	5	12
Capacity (5 tons)	50 kN	50 kN

> Description of components of the BP case Set 5-44

Puller	For bearing with bore		Thread	Length (L - mm)	Weight (g)
	Min.	Max.			
BP 5-7	5	7	M8	27	60
BP 8-11	8	11	M8	40	40
BP 12-15	12	15	M8	53	120
BP 16-19	16	19	M8	53	140
BP 20-26	20	26	M8	55	260
BP 28-34	28	34	M8	60	320
BP 35-44	35	44	M8	78	410

> Description of components of the BP case Set 45-100

Puller	For bearing with bore		Thread	Length (L - mm)	Weight (g)
	Min.	Max.			
BP 45-58	45	58	M10	91	860
BP 56-75	56	75	M10	115	2040
BP 74-100	74	100	M10	125	3140

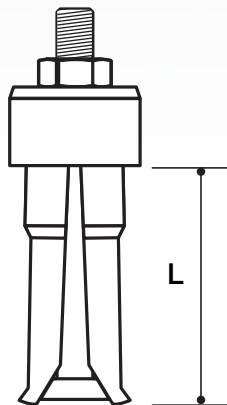

TECHNICAL DATA

DEEP-GROOVE BALL BEARING PULLER KIT

► P 19

Reference	TOOL BBPS 10-100 / Ball bearing puller set					
Contents	3 shafts, 28 arms, 22 metal rings, 3 O-rings, 1 crank, 1 centering pad					
bore diameter	For bearing extraction from 10 to 100 mm					
Case dimensions	490 x 500 x 130 mm					
Case weight	8.4 kg					
Capacity	70 kN (7 tons)					
Puller	For bearing with bore		Dimensions (mm)			Weight (g)
	Min.	Max.	A	C	L	
BBPSA	10	25	A1/A2 - 140 A3 - 160	5 6	A1/A2 - 160 A3 - 180	260 - 420
BBPSB	20	60	170	8	196	550 - 820
BBPSC	17	100	200	10	237	1260 - 1800

BBPS A	A1 ⁽¹⁾	28 x 3.00	6000* 6001* 6002* 6003*	6200*		16002* 16003* 16100* 16101*
	A2 ⁽¹⁾		6004 6005 6006	6201* 6202 6203	6300	
	A3 ⁽¹⁾			6204 6205	6301 6302 6303	62/22
BBPS B	B1 ⁽¹⁾	50 x 3.00	6007* 6008* 6009* 6010*			16011*
	B2 ⁽¹⁾		6011* 6012*	6206 6207	6304 6305 6306	62/28*
BBPS C	C1 ⁽¹⁾	85 x 3.00	6014* 6015*	6208 6209 6210	6307	6403
	C2 ⁽¹⁾		6018* 6019* 6020*	6211* 6212 6213*	6308 6309 6310 6311	6404 6405 6406

* Bearing not requiring an extraction ring.

(1) - Our recommendations may change depending on the make of the bearing.

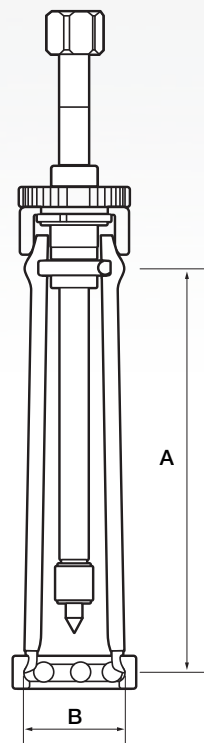
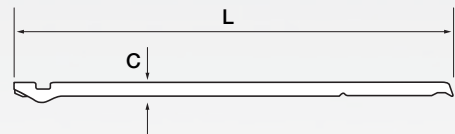

SELF-CENTERING PULLER (combined with 2/3 arms)

> P 20

Reference	TOOL SCMP 2/3-(Max. reach) / Self-Center Mech Puller							
Type	Capacity (tons)	Max. reach (mm)	Spread		Jaws dimensions			Weight (kg)
			Min. (mm)	Max. (mm)	A (mm)	B (mm)	C (mm)	
SCMP 2/3-120	2	80	36	120	8	6	15	1.6
SCMP 2/3-180	3	120	38	180	6	7	15	2.3
SCMP 2/3-270	5	160	42	270	11	10	25	4.3

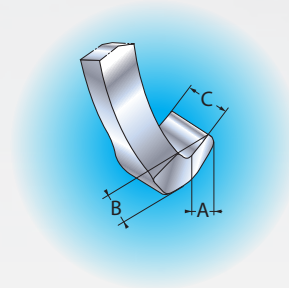
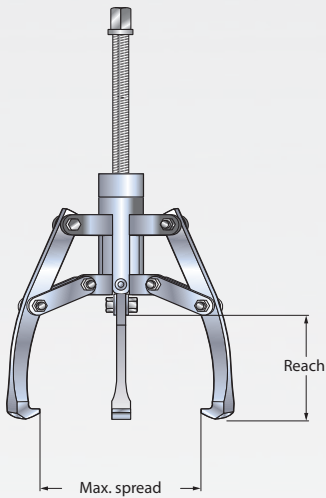

SELF-CENTERING HYDRAULIC PULLER (combined with 2 or 3 arms)

> P 21

Reference	TOOL SCHP (Capacity) TONS / Self-Center Hyd Puller											
Type	Capacity (ton)	Max. gripping distance (mm)	Cylinder stroke H (mm)	Spread (mm)		Dimensions (mm)						Weight (kg)
				Min.	Max.	A	B	C	E	F	G	
SCHP 4 Tons	4	190	60	68	315	13	10	22	40	42	22	9
SCHP 12 Tons	12	300	85	90	463	15	16.5	29	70	60	28	17
SCHP 20 Tons	20	325	111	120	520	20	27	33	62	80	40	28
SCHP 30 Tons	30	415	111	120	620	20	27	38	85	98	50	39

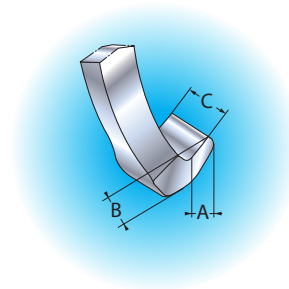
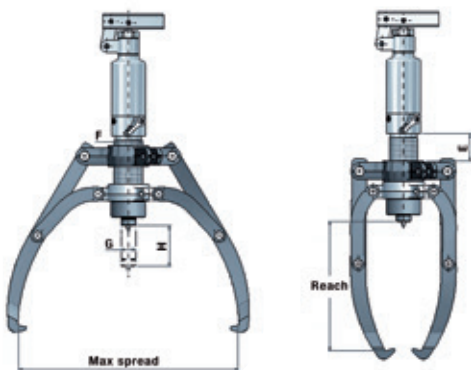

TECHNICAL DATA

ACCESSORY CASE FOR HYDRAULIC PULLER

> P 22

Reference	TOOL AS-SCHP (Hydraulic extractor capacity) T / acc set hyd puller		
Contents	1 pulling arm, 2 braces, 1 separator, 2 blades with 2 threaded studs		
Reference	Length of braces (mm)	spread Min./Max. (mm)	Weight with packaging (kg)
AS-SCHP 4 T	250	25 - 110	7
AS-SCHP 12 T	325	80 - 225	22



TRI-SECTION PULLING PLATE

> P 23

Reference	TOOL BP3S 50-210 / TRI-SECTION PULLING PLATE						
Materials	Forged steel alloy						
DIMENSIONS (mm)							
Shaft diameter Min. (A1) / Max. (A2) (mm)		Capacity (ton)	Max spread B (mm)	Length D (mm)	Thread E	Thickness F (mm)	Weight (kg)
26	160	4	216	240	5/8" - 11 UNC	8	3.5
50	210	8	280	285	3/4" - 16 UNF	31	5.5
90	340	12	460	430	7/8" - 16 UNF	45	16.5
140	495	30	660	600	1" - 14 UNF	61	41

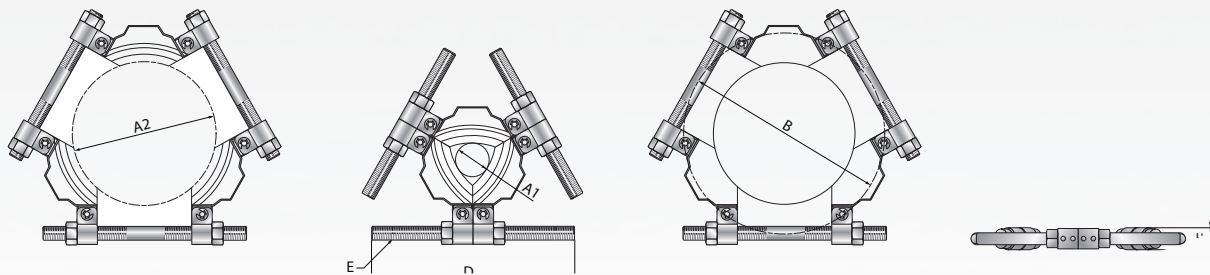

PULLER - STRIPPING KIT

► P 24

Reference	TOOL BPES 10-105
Contents	1 adjustable bridge, 1 separator, 2 removable puller arms 2 extensions, 1 tip protector, 2 coupling nuts
Case dimensions	490 x 500 x 130 mm
Case weight	11 kg
Capacity	100 kN (10 tons)

► Description of components of the BPES case 10-105

	Shaft diameter (mm)	Bore diameter (mm)	Outside diameter (mm)	Max. reach (mm)
Separator	10-105	-	175 (max.)	150
Internal gripping puller	-	159-222	-	160
External gripping puller	-	-	30-155	160

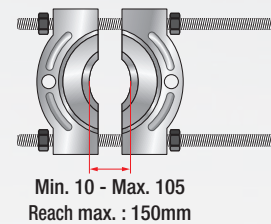
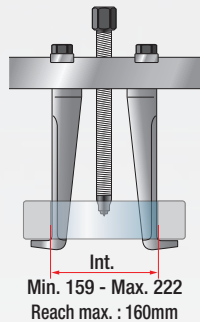
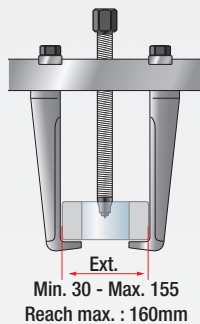

HYDRAULIC PULLER FOR MOUNTING AND REMOVAL

► P 25

Reference	TOOL PUSH/PULLER 8/12 Tons									
Contents	1 double acting hydraulic cylinder, 3 arms, 3 extensions, 1 internal gripping puller									
Type	Capacity (ton)	Reach (max.)	Spread - A		Dimensions (mm)					Weight (kg)
			Min.	Max.	B	C	D	E	F	
Thrust	8	130	44	280	270	140	28	M12-P1.75	30	19.5
Extraction (external)	12	240*	85	300	260	140	28	-	-	
Extraction (internal)	8	105	110	210	130-150	-	-	1"-12UNF	-	

* without adapter (180 mm with adapter)

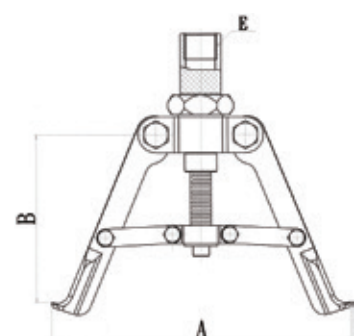
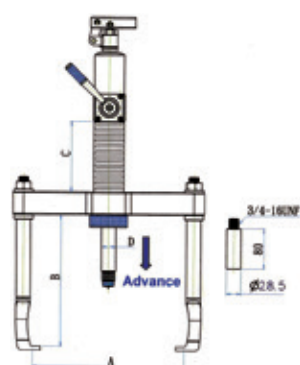
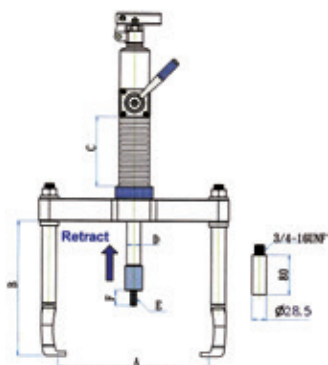

TECHNICAL DATA

HYDRAULIC NUTS (equipped with automatic piston return device) > P 28	
References	TOOL HMV (size) EBF / Hydraulic Nut (metric) TOOL HMVC (size) EBF / Hydraulic Nut (inches)
Materials	
HMV 10 EBF – HMV 40 EBF	Fine metric thread according to ISO 965-1998 Class 6H tolerance
HMV 41 EBF – HMV 200 EBF	Trapezoidal thread according to ISO 2901-1993 Class 7H tolerance
Nuts Sizes \leq HMV 54 EBF Sizes \leq HMV 92 EBF Sizes \leq HMV 200 EBF	Recommended pump references: Pump 700b-0.3 l / Pump 700b-0.9 l Pump 700b-0.9 l Pump 1500b-2,5L
Component Reference - hydraulic nuts	
Set of O-rings	Nut Reference followed by / Piston Seals: Example: TOOL HMV 15 / Piston Seals
Ball valve	1500 bar Reference: TOOL HMV BALL PLUG 1/4
Quick coupling connection (male)	With seal washer and connecting nipple Reference : TOOL HMV NIPPLE 1/4 Dimensions: see page 50

A-A (1 : 2)

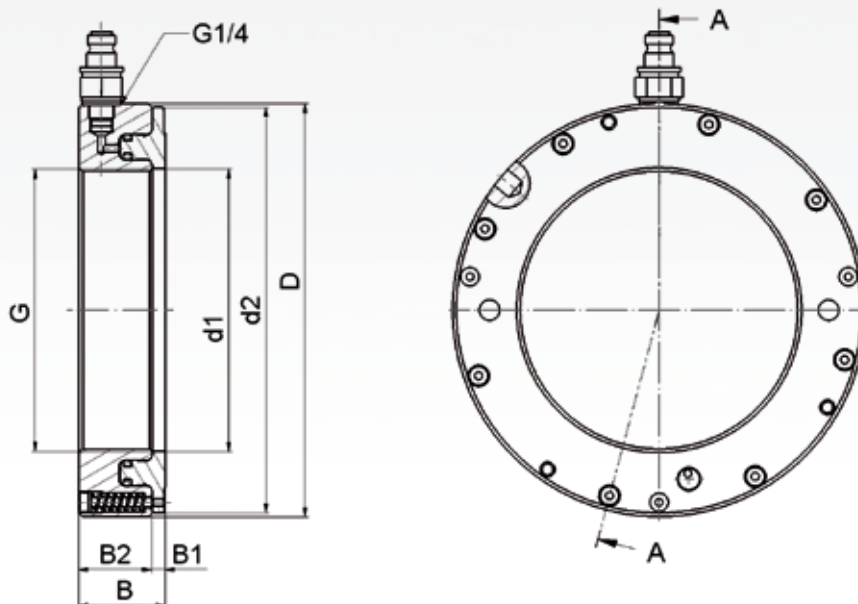

DIMENSIONS (MM) AND WEIGHT (KG) OF HYDRAULIC NUTS (metric)

Size	Thread	Outside diameter (mm)	Total width (mm)	Piston diameter (mm)	Permissible stroke of the piston (mm)	Flange width (mm)	Body width (mm)	Diameter (mm)	Surface of the piston (mm ²)	Weight (kg)
HMV ... EBF	G	D	B	max. d2		B1	B2	d1		
10	M50x1,5	114	43	110	5	5	38	50.5	2850	2.9
11	M55x2	120	43	116	5	5	38	55.5	3050	3
12	M60x2	125	43	121	5	5	38	60.5	3250	3
13	M65x2	130	43	126	5	5	38	65.5	3500	3.2
14	M70x2	135	43	131	5	5	38	70.5	3650	3.4
15	M75x2	140	43	136	5	5	38	75.5	3850	3.6
16	M80x2	146	43	142	5	5	38	80.5	4150	3.9
17	M85x2	150	43	146	5	5	38	85.5	4300	4
18	M90x2	156	43	152	5	5	38	90.5	4850	4.2
19	M95x2	162	43	158	5	5	38	95.5	5050	4.5
20	M100x2	166	44	162	5	6	38	100.5	5100	4.6
21	M105x2	172	44	168	5	6	38	105.5	5200	4.9
22	M110x2	178	44	174	5	6	38	110.5	5400	5.2
23	M115x2	182	44	178	5	6	38	115.5	5800	5.2
24	M120x2	188	44	184	5	6	38	120.5	5950	5.5
25	M125x2	192	44	188	5	6	38	125.5	6350	5.6
26	M130x2	198	44	194	5	6	38	130.5	6450	5.9
27	M135x2	204	44	200	5	6	38	135.5	6900	6.1
28	M140x2	208	45	204	5	7	38	140.5	7250	6.2
29	M145x2	214	46	210	5	7	39	145.5	7400	6.7
30	M150x2	220	46	216	5	7	39	150.5	7600	6.8
31	M155x3	226	46	222	5	7	39	155.5	8450	7.2
32	M160x3	232	47	228	6	7	40	160.5	8650	7.8
33	M165x3	238	47	234	6	7	40	165.5	8750	8.1
34	M170x3	244	48	240	6	7	41	170.5	9800	8.6
36	M180x3	256	48	252	6	7	41	180.5	11250	9.4
38	M190x3	270	50	266	7	8	42	191	11800	10.7
40	M200x3	282	51	278	8	8	43	201	12100	11.7
41	Tr205x4	288	51	284	8	8	43	207	13050	12.2
42	Tr210x4	294	52	290	9	8	44	212	13400	12.7
43	Tr215x4	300	52	296	9	8	44	217	14050	13.2
44	Tr220x4	306	52	302	9	8	44	222	14800	13.7
45	Tr225x4	312	53	308	9	8	45	227	15150	14.7
46	Tr230x4	318	53	314	9	8	45	232	15450	14.7
47	Tr235x4	326	54	322	10	8	46	237	16600	16.2
48	Tr240x4	330	55	326	10	9	46	242	17250	16.2
50	Tr250x4	342	55	338	10	9	46	252	17550	17.7
52	Tr260x4	356	56	352	11	9	47	262	19150	19.2
54	Tr270x4	368	57	364	12	9	48	272	20350	20.7
56	Tr280x4	380	58	376	12	9	49	282	21050	22.2
58	Tr290x4	390	58	386	13	9	49	292	22350	22.7
60	Tr300x4	404	61	400	14	10	51	302	23600	25.7

TECHNICAL DATA

DIMENSIONS (MM) AND WEIGHT (KG) OF HYDRAULIC NUTS (metric)

Size	Thread	Outside diameter (mm)	Total width (mm)	Piston diameter (mm)	Permissible stroke of the piston (mm)	Flange width (mm)	Body width (mm)	Diameter (mm)	Surface of the piston (mm ²)	Weight (kg)
HMV ... EBF	G	D	B	max. d2		B1	B2	d1		
62	Tr310x5	416	62	412	14	10	52	312	24850	27.2
64	Tr320x5	428	63	424	14	10	53	322	26250	29.7
66	Tr330x5	438	63	434	14	10	53	332	27500	30.2
68	Tr340x5	450	64	446	14	10	54	342	27750	31.7
69	Tr345x5	456	64	452	14	10	54	347	29350	32.7
70	Tr350x5	464	66	460	14	10	56	352	29800	35.2
72	Tr360x5	472	66	468	15	10	56	362	31250	35.7
73	Tr365x5	482	68	478	15	11	57	367	31600	38.7
74	Tr370x5	486	68	482	16	11	57	372	33300	39.2
76	Tr380x5	498	69	494	16	11	58	382	33500	40.7
77	Tr385x5	504	69	500	16	11	58	387	34050	41.2
80	Tr400x5	522	71	518	17	11	60	402	36600	45.7
82	Tr410x5	534	72	530	17	11	61	412	38200	48.2
84	Tr420x5	546	72	542	17	11	61	422	39900	50.2
86	Tr430x5	556	73	552	17	11	62	432	40750	52.7
88	Tr440x5	566	74	562	17	12	62	442	42400	54.2
90	Tr450x5	580	76	576	17	12	64	452	44100	57.7
92	Tr460x5	590	76	586	17	12	64	462	45100	60.2
94	Tr470x5	602	77	598	18	12	65	472	46800	62.2
96	Tr480x5	612	77	608	19	12	65	482	48600	63.2
98	Tr490x5	624	78	620	19	12	66	492	49500	66.2
100	Tr500x5	636	79	630	19	12	67	502	49950	70.2
102	Tr510x6	648	80	642	20	12	68	512	53300	74.2
104	Tr520x6	658	81	652	20	13	68	522	54250	75.2
106	Tr530x6	670	82	664	21	13	69	532	56150	79.2
108	Tr540x6	682	82	676	21	13	69	542	58200	81.2
110	Tr550x6	693	83	687	21	13	70	552	59150	84.2
112	Tr560x6	704	84	698	22	13	71	562	61150	88.2
114	Tr570x6	716	85	710	23	13	72	572	63200	91.2
116	Tr580x6	726	85	720	23	13	72	582	64200	94.2
120	Tr600x6	748	86	742	23	13	73	602	67400	100.2
126	Tr630x6	782	88	776	23	14	74	632	72850	110.2
130	Tr650x6	804	89	798	23	14	75	652	76100	115.2
134	Tr670x6	826	90	820	24	14	76	672	79450	120.2
138	Tr690x6	848	91	842	25	14	77	692	84200	127.2
142	Tr710x7	870	93	864	25	15	78	712	87700	135.2
150	Tr750x7	912	94	906	25	15	79	752	95050	146.2
160	Tr800x7	965	96	959	25	16	80	802	103800	161.2
170	Tr850x7	1020	99	1014	26	16	83	852	114450	181.2
180	Tr900x7	1075	103	1069	30	17	86	902	123950	205.2
190	Tr950x8	1126	103	1120	30	17	86	952	135450	218.2
200	Tr1000x8	1180	105	1174	34	17	88	1002	145700	239.2

DIMENSION (MM) AND WEIGHT (KG) OF HYDRAULIC NUTS (dimension in inches)

Size	Thread	Number of threads per inch	Outside diameter (in.)	Total width (in.)	Piston diameter (in.)	Permissible stroke of the piston (in.)	Flange width (in.)	Body width (in.)	Diameter (in.)	Surface of the piston (in. ²)	Weight (lb)
HMVC ... EBF	G		D	B	max. d2		B1	B2	d1		
10	1.967	18	4.5	1.7	4.4	0.20	0.20	1.5	2.0	4.4	6.3
11	2.157	18	4.7	1.7	4.6	0.20	0.20	1.5	2.2	4.8	6.8
12	2.360	18	4.9	1.7	4.8	0.20	0.20	1.5	2.4	5.1	7.2
13	2.548	18	5.1	1.7	5.0	0.20	0.20	1.5	2.6	5.4	7.6
14	2.751	18	5.3	1.7	5.2	0.20	0.20	1.5	2.8	5.8	7.9
15	2.933	12	5.5	1.7	5.4	0.20	0.20	1.5	3.0	6.1	8.3
16	3.137	12	5.7	1.7	5.6	0.20	0.20	1.5	3.2	6.4	8.7
17	3.340	12	5.9	1.7	5.8	0.20	0.20	1.5	3.4	6.7	9.1
18	3.527	12	6.1	1.7	6.0	0.20	0.20	1.5	3.6	6.8	9.5
19	3.730	12	6.4	1.7	6.2	0.20	0.20	1.5	3.8	7.5	10.0
20	3.918	12	6.5	1.7	6.4	0.20	0.24	1.5	4.0	7.5	10.4
21	4.122	12	6.8	1.7	6.6	0.20	0.24	1.5	4.2	8.1	11.0
22	4.325	12	7.0	1.7	6.9	0.20	0.24	1.5	4.4	8.8	11.6
24	4.716	12	7.4	1.7	7.2	0.20	0.24	1.5	4.8	9.4	12.4
26	5.106	12	7.8	1.7	7.6	0.20	0.24	1.5	5.2	10.1	13.2
28	5.497	12	8.2	1.8	8.0	0.20	0.28	1.5	5.6	10.7	14.3
30	5.888	12	8.7	1.8	8.5	0.20	0.28	1.5	6.0	12.3	16.0
32	6.284	8	9.1	1.9	9.0	0.24	0.28	1.6	6.4	14.0	18.0
34	6.659	8	9.6	1.9	9.4	0.24	0.28	1.6	6.8	15.8	19.9
36	7.066	8	10.1	1.9	9.9	0.24	0.28	1.6	7.2	17.7	21.5
38	7.472	8	10.6	2.0	10.5	0.28	0.31	1.7	7.6	18.5	24.9
40	7.847	8	11.1	2.0	10.9	0.31	0.31	1.7	8.0	19.4	27.3
44	8.628	8	12.0	2.0	11.9	0.31	0.31	1.7	8.8	21.1	31.9
46	9.125	8	12.5	2.1	12.4	0.31	0.31	1.8	9.2	21.9	34.7
48	9.442	6	13.0	2.2	12.8	0.35	0.35	1.8	9.6	25.4	37.8
52	10.192	6	14.0	2.2	13.9	0.35	0.35	1.9	10.4	27.2	44.4
56	11.004	6	15.0	2.3	14.8	0.39	0.35	1.9	11.2	30.7	51.4
60	11.785	6	16.1	2.4	16.0	0.39	0.39	2.0	12.0	37.0	64.4
64	12.562	6	16.9	2.5	16.8	0.43	0.39	2.1	12.8	39.2	70.8
68	13.339	5	17.7	2.5	17.6	0.47	0.39	2.1	13.5	41.4	75.7
72	14.170	5	18.9	2.6	18.7	0.51	0.39	2.2	14.3	51.8	89.7
76	14.957	5	19.7	2.7	19.5	0.55	0.43	2.3	15.1	54.4	98.2
80	15.745	5	20.9	2.8	20.7	0.55	0.43	2.4	15.9	54.8	116.4
84	16.532	5	21.9	2.8	21.7	0.55	0.43	2.4	16.7	60.8	127.7
88	17.319	5	22.6	2.9	22.5	0.55	0.43	2.4	17.5	63.4	134.1
92	18.107	5	23.6	3.0	23.5	0.59	0.47	2.5	18.3	71.3	150.6
96	18.894	5	24.4	3.0	24.3	0.63	0.47	2.6	19.1	78.2	158.0
100	19.682	5	25.6	3.1	25.4	0.63	0.47	2.6	19.8	85.7	181.6
106	20.867	4	26.8	3.2	26.6	0.67	0.51	2.7	21.0	85.89	199.4
112	22.048	4	28.1	3.3	28.0	0.71	0.51	2.8	22.2	87.0	221.1
120	23.623	4	29.9	3.4	29.8	0.75	0.51	2.9	23.8	101.0	249.2
126	24.804	4	31.1	3.5	30.9	0.75	0.55	2.9	25.0	105.6	266.4
134	26.379	4	33.1	3.5	32.9	0.87	0.55	3.0	26.5	125.3	307.8
142	27.961	3	34.6	3.7	34.5	0.91	0.59	3.1	28.1	132.1	337.1
150	29.536	3	36.2	3.7	36.1	0.91	0.59	3.1	29.7	138.9	358.1
160	31.504	3	38.2	3.8	38.0	0.98	0.63	3.1	31.7	147.4	387.1
170	33.473	3	40.6	3.9	40.4	1.02	0.63	3.3	33.6	179.2	448.0
180	35.441	3	43.3	4.1	43.1	1.10	0.67	3.4	35.6	238.6	545.6
190	37.410	3	45.3	4.1	45.1	1.10	0.67	3.4	37.6	250.8	575.3

TECHNICAL DATA

MANUAL HYDRAULIC PUMP KITS

> P 29

References	TOOL PUMP SET 700B-(Reservoir capacity) L / Pump with accessories TOOL PUMP SET 1500B 2,5 L / Pump with accessories		
Contents	Pump Set 700b-0.3 L	Pump Set 700b-0.9 L	Pump Set 1500b - 2.5 L
Ⓐ 1 2-stage manual pump	700 bar pump with 0.3 litre reservoir	700 bar pump with 0.9 litre reservoir	1500 bar pump with 2.5 litre reservoir
Ⓑ 1 adaptor for pressure gauge*	1/4" male, 3/8" female	3/8" male, 3/8" female	1500 bar pressure gauge block
Ⓒ 1 pressure gauge	700 bar	700 bar	
Ⓓ 1 hose	700 bar, length 1.5 m	700 bar, length 3 m	1500 bar, length 3 m
Ⓔ 1 quick coupling connection (female)	G 1/4 (1500 bar)	G 1/4 (1500 bar)	G 1/4 (1500 bar)

> Description of the manual hydraulic pump kit components

Ⓐ ULTRA LIGHT MANUAL PUMP (with two stages)

> P 29

Reference	TOOL PUMP 700b - (reservoir capacity) L TOOL PUMP 1500B 2.5 L												
Material	Glass fibre reinforced composite tank												
Reference TOOL +	Nominal pressure 1 st stage (bar)	Nominal pressure 2 nd stage (bar)	Volume/stroke 1 st stage (cm ³)	Volume/stroke 2 nd stage (cm ³)	Tank capacity (cm ³)	Weight (bare pump) (kg)	DIMENSIONS (mm)						
	A	B	C	D	E	G	H	J	L	M	N	P	S
PUMP 700b-0.3l	185	336	28	85	28	1/4" - 18 NPTF	319	19	143	-	95	80	7
PUMP 700b-0.9l	344	533	36	99	33	3/8" - 18 NPTF	522	30	177	16	120	-	-

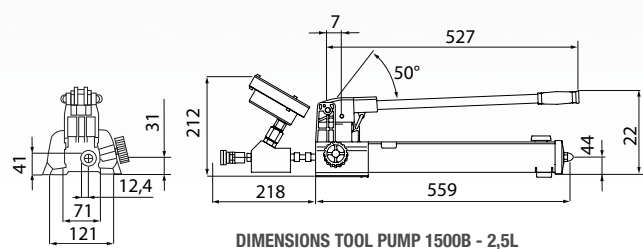
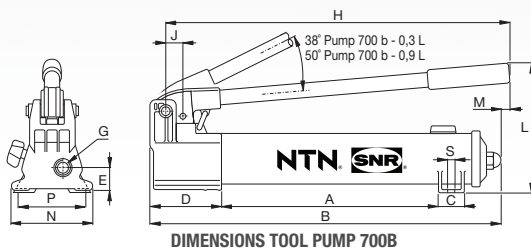

Ⓑ PRESSURE GAUGE ADAPTOR ACCORDING TO PUMP

> P 29

Reference	TOOL gauge adapter (Reservoir capacity) L		
Reference TOOL+	Pressure gauge port	Male end	Female end
GAUGE ADAPTER 0.3 l	NPTF 1/4"	NPTF 1/4"	NPTF 3/8"
GAUGE ADAPTER 0.9 l		NPTF 3/8"	

Ⓒ PRESSURE GAUGE

> P 29

Reference	TOOL PUMP GAUGE 700
Permitted pressure	700 bar (10 000 psi)
Precision (% full scale)	+/- 1.0 (-1.5%)
Graduation	Bar
Scales	Bar
Large graduations	100
Small graduations	20
Connecting thread C	1/4" NPTF
Diameter A	100 mm
Height D	130 mm
Thickness B	35 mm

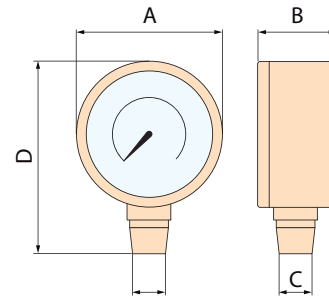

* For the 1500 bar – 2.5L pump, B and C are supplied as a complete unit. For information on “pressure gauge kit” spare parts, please contact us.

Ⓓ HIGH PRESSURE HOSE

> P 29

Reference	TOOL HYDRAULIC HOSE (length in mm)					
Material	Thermoplastic reinforced with layers of woven steel wire Polyurethane envelope					
References	Max. working pressure (bar)	Inner diameter (mm)	Length (mm)	Weight (kg)	Connection end 1	Connection end 2 (male)
TOOL HYDRAULIC HOSE 1500	700	6.4	1,500	0.8	3/8" - 18 NPTF	G 1/4 750 bar
TOOL HYDRAULIC HOSE 3000	700	6.4	3,000	1.5	3/8" - 18 NPTF	G 1/4 750 bar
TOOL 1500B HYDRAULIC HOSE 3000	1500	5	3,000	1.5	1/4 BSPP	G 1/4 1500 bar

Ⓔ QUICK COUPLING CONNECTION, FEMALE (connection on end 2)

> P 29

Reference	TOOL PUMP COUPLING 1/4
Material	High strength steel. Black zinc treatment
Type of valve	Flat face for minimum discharge of fluid on disconnection
Maximum service pressure	1500 bar

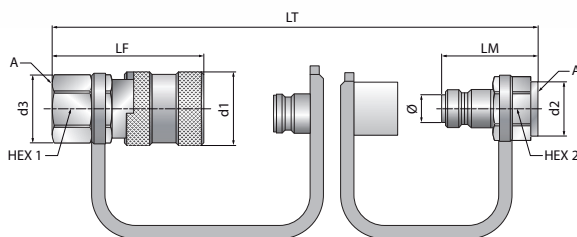

Note – Seal washer and connecting nipple included in HMV NIPPLE 1/4 are not represented on the drawing.

Thread A BSPP	d1 (mm)	d3 (mm)	Nut Hex1 (mm)	LF (mm)	d2 (mm)	Nut Hex2 (mm)	LM (mm)	LT (mm)	∅ (mm)	Reference Female TOOL+	Weight (g)	Reference Male TOOL+	Weight (g)
G 1/4	28.2	26.8	24	59.5	24.5	22	38	79.5	14.9	PUMP COUPLING 1/4	192	HMV NIPPLE 1/4	69

TECHNICAL DATA

HEAT-RESISTANT GLOVES		> P 32
Reference	TOOL GLOVE HEAT RESISTANT	
Material	KEVLAR	
Lined	Coton	
Single size	10.5	
Maximum temperature	350°C	
Quantity per packet	1	

SET OF CALIBRATED FEELER GAUGES OF CALIBRATED THICKNESS						> P 32
Reference	FEELER GAUGE TOOL (gauge length)					
	Number of gauges	Field of measurement (mm)	Blade thickness (1/100 of mm)		Length (mm)	Weight (g)
TOOL FEELER GAUGES 100	17	0.02 – 0.5	0.02	0.15	100	65
TOOL FEELER GAUGES 150			0.03	0.20		
			0.04	0.25		
TOOL FEELER GAUGES 300			0.05	0.30	150	85
			0.06	0.35		
			0.07	0.40		
			0.08	0.45	300	175
			0.09	0.50		
			0.10			

INFRARED THERMOMETER WITH LASER
> P 33
Reference TOOL LASERTEMP 301 / IR Thermometer

APPLIANCE CHARACTERISTICS

Spectral response	8 -14 mm
Optics	D.S : 30:1 (50 mm to 1500 mm)
Response time	Less than one second
Temperature range	From -50 to +850°C
Accuracy*	From -50 to -20°C : ±5°C From -20 to +200°C : ±1.5% of the reading ±2°C From +200 to +538 °C : ±2% of the reading ±2°C From +538 to +850°C : ±3.5% of the reading ±5°C
Display resolution	0.1°C
Emissivity	Adjustable between 0.10 and 1.00 (pre-set at 0.95)
Screen indication :	Indication of level exceeded “-01” for under-range “01” for over-range
Laser aiming device	Wave length : 630-670 nm output lower than 1mW, class 2 (II)
Indication of positive or negative temperature	Automatic (no indication for a positive temperature) Sign (-) for a negative temperature
Screen	4½ digits with backlit LCD screen
Auto switch-off:	After 7 seconds of inactivity High/low alarm
Thresholds	Flashing signal on screen and audible signal with adjustable thresholds
Supply	9 V alkaline battery
Battery life	38 hr (laser and backlight inactive) 15 hr (laser and backlight active)
Temperature for use	From 0 to +50°C
Storage temperature	From -20°C to +60°C
Relative humidity	From 10% to 90% RH in operation and less than 80% RH in storage
Dimensions	175 x 110 x 45 mm
Weight	230 g (including battery)
Memory	20 temperature values with unit of measurement (°C or °F)

** Accurate for an ambient temperature between 18 and 28°C (with relative humidity below 80%)*
CHARACTERISTICS OF THE THERMOCOUPLE PROBE K

Temperature range	From -40 to +400°C
Display range	From -50 to +1370°C
Resolution	0.1°C
Accuracy	±1.5% of the reading ±3°C
Cable length	1 m

 The devices meet the following standards 1992, electromagnetic emissions
 EN 50081-1: 1992, electromagnetic interference
 EN 50082-1: 1992, electromagnetic susceptibility

GLOSSARY

Descriptions	References	Catalogue pages	Technical data pages
Cold mounting case	TOOL IFT SET 33 / Industry Fitting Tool Set	P 09	P 36
“Contact corrosion” anti-fretting paste	LUB ANTI-FRETTING PASTE (packaging)	P 11	P 36
Articulated manual pin spanner	TOOL PS (min. size – max. size) / Pin Spanner	P 11	P 36
Articulated manual hook spanner	TOOL HS (min. size –max. size) / Hook Spanner	P 11	P 36
Induction heater	TOOL FAST THERM (capacity) / Induction Heater	P 14-15	P 38
Induction heater	TOOL SAFE THERM (capacity) Induction Heater	P 15-16	P 39
Only bar for induction heater	TOOL FT (capacity) - YOKE (Min. Bore)	P 14-16	P 40
Temperature probe for induction heater	TOOL TEMP PROBE (Size)	P 14-16	P 38-39
Bar lifting device for heater	TOOL FT (Capacity) LIFTING DEVICE	P 16	P 39
Bore puller kit with internal gripping	TOOL BP SET (min. size – max. size) / Bore Puller	P 18	P 41
Deep-groove ball bearing puller kit	TOOL BBPS 10-100/ball bearing / Puller set	P 19	P 42
Self-centering mechanical puller	TOOL SCMP 2/3 - (max. reach) / Self-Center Mech Puller	P 20	P 43
Self-centering hydraulic puller	TOOL SCHP (capacity) TONS / Self-Center Hyd Puller	P 21	P 43
Accessories case for self-centering hydraulic puller	TOOL AS-SCHP (Capacity) T / Acc. Set Hyd Puller	P 22	P 44
Tri-section pulling plate	TOOL BP3S 50-210 / TRI-SECTION PULLING PLATE	P 23	P 44
Mechanical spindle puller-separator Kit	TOOL BPES 10-105 / Back Puller extract set	P 24	P 45
Hydraulic puller for mounting and removal	TOOL PUSH/PULLER 8/12 Tons	P 25	P 45
¼” gas ball valve	TOOL HMV BALL PLUG 1/4	P 28	P 46
Set of O-rings for hydraulic nut	TOOL HMV (Size) / Piston Seals	P 28	P 46
Hydraulic nut with metric thread and piston return device	Hydraulic Nut	P 28	P 46-49
Manual hydraulic pump kit	TOOL PUMP SET 700B-(reservoir capacity) L / Pump with accessories	P 29	P 50
Manual hydraulic pump kit	TOOL PUMP SET 1500B - 2.5 l / Pump with accessories	P 29	P 50
Oil for pump 700b and 1500b	TOOL HYDRAULIC OIL 1L	P 29	P 50
Pump pressure gauge, 700 bars	TOOL PUMP GAUGE 700	P 29	P 51
Quick coupling connection, ¼ gas (female)	TOOL PUMP COUPLING 1/4	P 29	P 51
Pressure gauge adapter depending on pump	TOOL gauge ADAPTER (Reservoir capacity)	P 29	P 51
High-pressure hose with quick coupling connector (female)	TOOL HYDRAULIC HOSE (Length mm) TOOL 1500b HYDRAULIC HOSE 3000	P 29	P 51
Quick coupling connection, ¼ gas (male)	TOOL HMV NIPPLE ¼	P 29	P 51
Thermal insulation gloves	TOOL GLOVE HEAT RESISTANT	P 32	P 52
Set of feeler gauges	TOOL FEELER GAUGES (Length)	P 32	P 52
Infrared thermometer with laser sighting targeting ratio 30 : 1	TOOL LASERTEMP 301 / IR Thermometer	P 33	P 53



With our “field” experts, you boost the operational efficiency of

- By cutting your maintenance costs;
- By improving the quality of your work;
- By optimizing the service life of equipment.

The Bearing box proposes:

- Practical training
- Technical assistance
- Demonstration of maintenance product tools

Distributed by:

This document is the exclusive property of NTN-SNR ROULEMENTS. Any total or partial reproduction hereof without the prior consent of NTN-SNR ROULEMENTS is strictly prohibited. Legal action may be brought against anyone breaching the terms of this paragraph.

NTN-SNR ROULEMENTS shall not be held liable for any errors or omissions that may have crept into this document despite the care taken in drafting it. Due to our policy of continuous research and development, we reserve the right to make changes without notice to all or part of the products and specifications mentioned in this document.

© NTN-SNR ROULEMENTS, international copyright 2017.