

SOLUTIONS NTN-SNR TAILOR-MADE SEALING FOR YOUR IMPLEMENTS



www.ntn-snr.com



With You



Zinc-plated shield
equipped with a single lip seal to seal the contact with the outer ring (zinc-plated)

AGR sealing system

Triple lip L3
Excellent protection against pollution

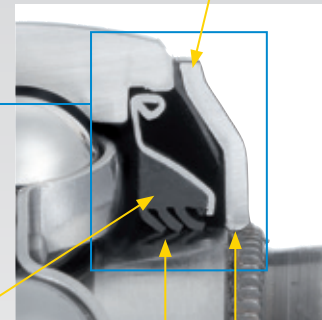

For lifelong lubrication:

High-performance grease with fill factor of 90%:

- Good protection against wear
- Suitable for heavy loads

Crimped shield
on inner ring
(zinc-plated)



**CREATED TO INCREASE
PRODUCTIVITY,
PERFORMANCE AND
RELIABILITY IN HARSH
ENVIRONMENTS**

ALL-PURPOSE BEARING

Benefits

- Protection against splashes in very tough environments
- Sealing suitable for high-pressure cleaning
- Lifelong lubricated insert - no need to re-grease

Compatible with all self-aligning cast iron ball bearings in the NTN-SNR range

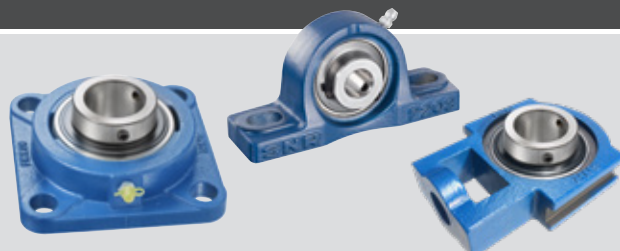

AGR: INSERT BEARINGS FOR IMPLEMENTS

UC...AGR tightening by set screws (2 possible rotation directions)

Description	d mm	D mm	C mm	B mm	S mm	m mm	G	r mm	Load capacities		Weight kg
									Dyn. (Cr) kN	Stat. (Cor) kN	
UC206AGR ²	30	62	19	39	15,9	5	M6x1	0,6	19,5	11,2	0,31
UC207AGR	35	72	20	42,9	17,5	6,5	M8x1	1,1	25,7	15,2	0,5
UC208AGR	40	80	21	49,2	19	8	M8x1	1,1	29,6	18,2	0,63
UC209AGR	45	85	22	49,2	19	8	M8x1	1,1	31,85	20,8	0,73
UC210AGR	50	90	23	51,6	19	9	M8x1	1,1	35,1	23,2	0,8
UC211AGR	55	100	25	55,6	22,2	9	M8x1	1,5	43,55	29,2	1,1
UC212AGR	60	110	27	65,1	25,4	10,5	M10x1,25	1,5	52,5	32,8	1,37
UC215AGR ¹	75	130	30	77,8	33,3	12	M12x1,25	2	66	49,5	2,16
UC308AGR	40	90	28	58,2	22,22	8,5	M10x1,25	2	40,56	24	1,1
UC309AGR	45	100	30	57	22	9	M10x1,25	2	53	31,8	1,26
UC310AGR	50	110	32	70	26	13	M10x1,25	2	61,75	37,8	1,85

¹ On request (please enquire)

² Wider dimensions than the standard version

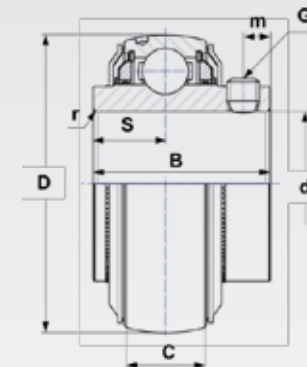

EX...AGR Fixing to shaft using eccentric locking collar (1 rotation direction)

Description	d mm	D mm	C mm	B mm	B1 mm	S mm	d1 mm	m mm	B2 mm	G	r mm	Load capacities		Weight kg
												Dyn. (Cr) kN	Stat. (Cor) kN	
EX207AGR	35	72	20	37,6	51,1	18,8	55,6	6,5	17,5	M8x1	1,1	25,7	15,2	0,64
EX208AGR	40	80	21	42,8	56,3	21,4	60,3	6,5	18,3	M8x1	1,1	29,6	18,2	0,74
EX209AGR	45	85	22	42,8	56,3	21,4	63,5	6,5	18,3	M8x1	1,1	31,85	20,8	0,87
EX210AGR	50	90	23	49,2	62,7	24,6	69,9	6,5	18,3	M8x1	1,1	35,1	23,2	1,01
EX211AGR	55	100	25	55,4	71,3	27,7	76,2	8	20,7	M10x1,25	1,5	43,55	29,2	1,35
EX212AGR	60	110	27	61,8	77,7	30,9	84,2	8	22,3	M10x1,25	1,5	52,5	32,8	1,67
EX308AGR	40	90	28	49,51	65,31	22,21	63,5	8	20,6	M10x1,25	2	40,65	24	1,28

¹ Wider dimensions than the standard version

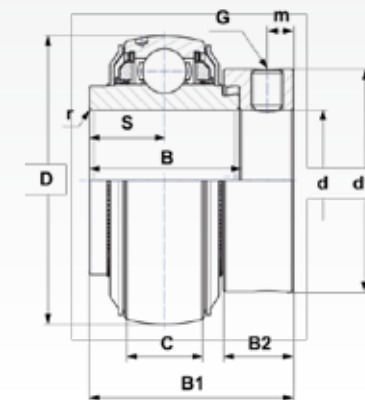

Le présent document est la propriété exclusive de NTN-SNR ROULEMENTS. Toute reproduction totale ou partielle sans autorisation préalable de NTN-SNR ROULEMENTS est formellement interdite. En cas de violation du présent paragraphe, vous vous exposez à des poursuites judiciaires. Les erreurs ou omissions qui auraient pu se glisser dans ce document malgré le soin apporté à sa réalisation n'engagent pas la responsabilité de NTN-SNR ROULEMENTS. En raison de notre politique de recherche et développement continue, nous nous réservons le droit de modifier sans préavis, tout ou partie des produits et spécifications mentionnés dans ce document. © NTN-SNR ROULEMENTS, copyright international 2017.

NTN-SNR ROULEMENTS - 1 rue des Usines - 74000 Annecy
RCS ANNECY B 325 821 072 - Code APE 2815Z - Code NACE 28.15
www.ntn-snr.com



With You

