



R140.06/EN/03/2022

R140.06

Disassembly / Assembly recommendations

<p>NISSAN : Interstar (I, II et II FL) OPEL : Movano (A, A FL et A FL 2) R.V.I : Mascott RENAULT : Master II , Master II phase 2 et phase 2 FL VAUXHALL : Movano (A, A FL et A FL 2)</p>	<p>OE reference <u>7701206740,</u> <u>4403023, 9111023</u></p>
---	---

IDENTIFICATION OF WHEEL KIT R140.06



Traceability: SNR FC.40918.S02

COMMON FAILURES INVOLVING KIT R140.06

PROBLEMS WITH ROLLING NOISE AND BEARING DAMAGE

PROBABLE CAUSES

Incorrect installation of the bearing.

Misalignment problems can occur when installing the hub.

If the bearing becomes misaligned during the fitting process and is then removed and refitted it causes several problems. The most common problem is the assembly ring being forced out of its retaining groove, when the bearing is refitted the assembly ring gets squashed between the small inner faces of the bearing. When the bearing is torque up in its final part of the fitting process, the small inner collars of the bearing are pushed together, breaking the collars (fig1) and cracking (fig2) the inner rings.



The fragments of the broken collar then find their way into the raceways of the bearing this soon results in noisy bearing and eventually destroys the bearing entirely



This problem will be highlighted by play in the wheel bearing and the bearing quickly becoming noisy after fitment. This normally leads to a rapid bearing failure and possible damage to the peripheral elements (hub, transmission, brake disc etc).

Play in the bearing.

This can occur if the assembly is not tightened correctly when fitted or a gradual loosening of the centre nut whilst in use. A damaged or worn hub will also allow play in the bearing.

Play in the bearing soon causes a noisy bearing, and a premature failure of the bearing (**no. 3**).



The tightening torque for the retaining nut is 360 Nm.

REPLACEMENT

Special tools

- Mandrel: OE (Tav.1450-01)
- Installation fixture: OE (Tav.1450-02)



Safety precautions

Always replace corroded or damaged nuts and bolts.

Tightening torques

- Brake caliper bolts (no. 1): Upper bolt: **80 Nm** ; lower bolt: **30 Nm**
- Support bolt (no. 2): **105 Nm**
- Lower fastener of the shock absorber (no. 4): **120 Nm**
- Brake bracket bolt : **110 Nm**
- Brake disc(s) bolt(s): **14 Nm**
- Upper fastener of the shock absorber: **100 Nm**
- Drive shaft bolt: **360 Nm**
- Wheel bolt: **172 Nm**

REMOVAL

1) Raise up the vehicle on a platform.

Remove the front wheels

2) Remove the under guard

3) Unscrew the brake caliper bolts (no. 1)

4) Remove the brake backing plate/caliper assembly

5) Remove the brake disc

6) Remove the ABS speed sensor

7) Use a suitable gearbox hoisting device to support the lower arm
(No. 3)

8) Remove the lower shock absorber bolt
(no. 4), then the remove the upper bolts

9) Remove the shock absorber

10) Remove the front spring

11) Unscrew the bolt from the steering rod ball joint

12) Unscrew the control arm bolt (see arrow)

13) Unscrew the clamping bolt (no. 2)

14) Unscrew the drive shaft bolt

15) Remove the kingpin

16) Install the special tool (no. 5)

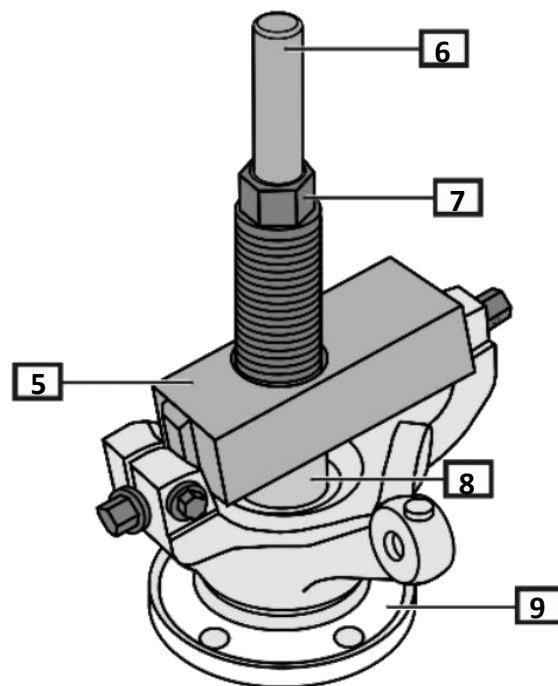
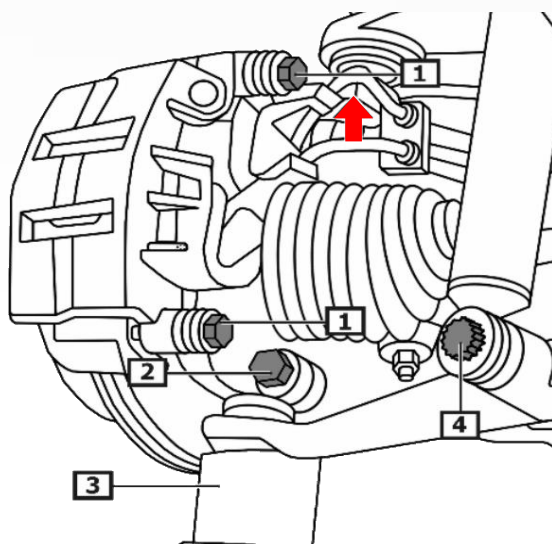

- 17) Screw the pin all the way in (no. 7)
- 18) Loosen the kingpin while tapping the mandrel (no. 6)
- 19) Rotate the pin and apply pressure to the hub (no. 7 and 9)
Special tool required
 Assembly jig (no. 5): OE (Tav. 1450-02)
- 20) Remove the stop ring
- 21) Use a suitable tool to extract the wheel bearing

RE-INSTALLATION

- 1) Press the new bearing into place
- 2) Replace the stop ring
- 3) Install the kingpin/bearing assembly on the hub
 Make sure it is well-seated in order to ensure that the assembly is correctly aligned.
- 4) Re-install the remaining components in reverse order of removal



Recommendations

Carefully follow all recommendations and use the correct methods of installation, make sure that all parts supplied in the kit such as bolts, nuts and washers are replaced along with the bearing.

Follow the vehicle manufacturer's installation procedures and apply the specified tightening torques.

When replacing the kit, refer to the technical datasheet "Wheel bearing installation/removal" available on our website: http://www.ntn-snr.com/portal/site/fr-fr/index.cfm?page=/portal/home/documentation#autoaftermarket_20



Scan this QR code to access our online catalogue.

FOLLOW THE RECOMMENDATIONS OF THE VEHICLE MANUFACTURER!

©NTN-SNR ROULEMENTS

The contents of this document are the copyright of the publisher and any reproduction, even partial, is prohibited without permission. Despite the care taken in preparing this document, NTN-SNR Roulements disclaims any liability for errors or omissions that may slip through, as well as for losses or direct or indirect damage arising from its use.

