



GA357.09/GB-07/2022

# GA357.09

## Assembly/disassembly recommendations

<p><b>AUDI:</b> A3 série 1 (AU34)</p> <p><b>SEAT:</b> Cordoba III, Ibiza II, Leon I, Toledo série 2 SKODA: Octavia I, Octavia I FL</p> <p><b>VOLKSWAGEN:</b> Bora, Caddy II, Golf IV, New Beetle (I et I FL), Polo VI</p>	<p><b>ENGINES</b> 1.9 Tdi</p>	<p><b>OE REFERENCE</b> 038903315C</p>
---	-----------------------------------	---

### IDENTIFY ROLLER TENSIONER GA357.09

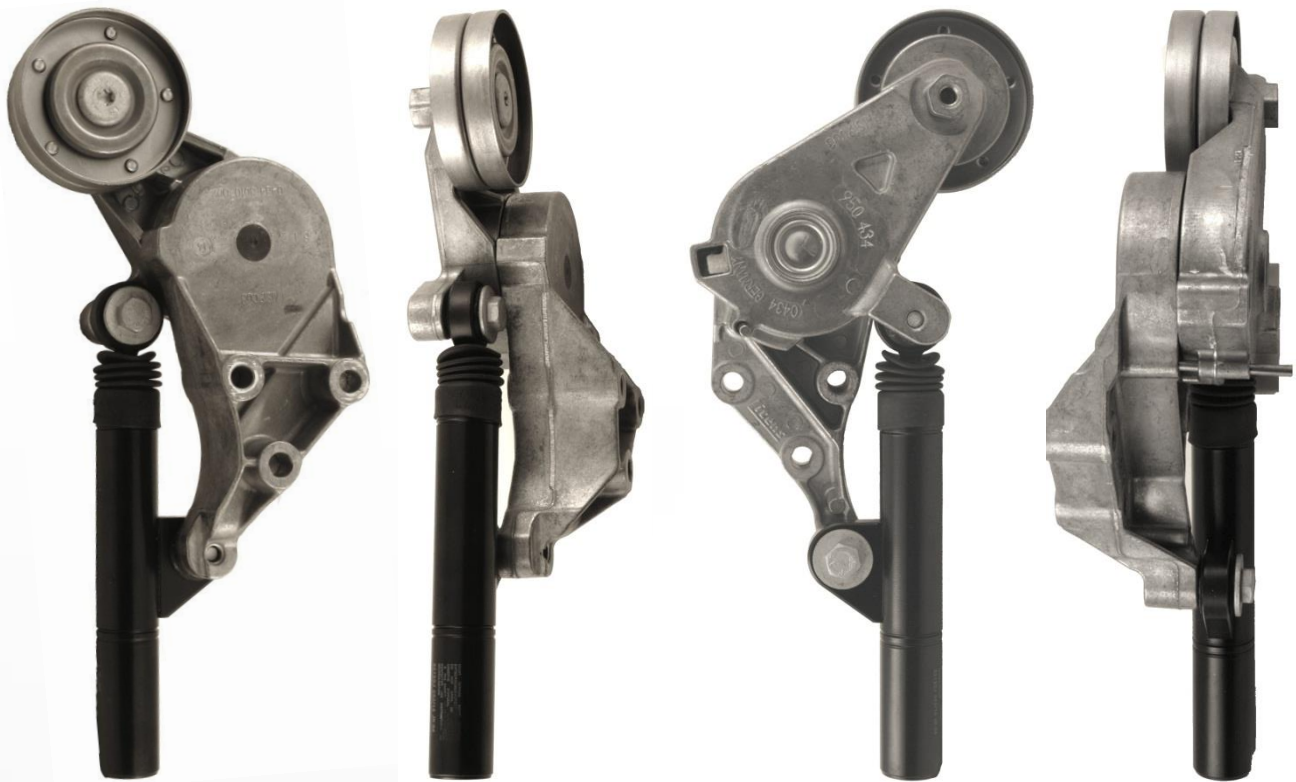

Traceability

## COMMON PROBLEMS

### PROBLEMS WITH BREAKAGE OF ALUMINUM SUPPORT

#### Probable causes

A worn over-running freewheel alternator pulley. Thus, the freewheel alternator pulley is no longer overrunning, resulting in strong acyclic motion in the belt.

All this leads to abnormal vibrations from the belt. The GA357.09 is not designed to absorb violent shocks from the belt, the aluminum support is thus liable to fail after a certain operating period. This can even lead to the destruction of the bearing.

#### Fixed pulley (not over-running) installed instead of the over-running freewheel alternator pulley.

The use of over-running freewheel alternator pulley limits the load on the other components in the accessory drive.

#### A problem with the belt routing.

The belt has been ejected from the grooves of the various pulleys, resulting in a misalignment. It is thus out of alignment. Such a phenomenon is related to strong acyclic movements in the belt.

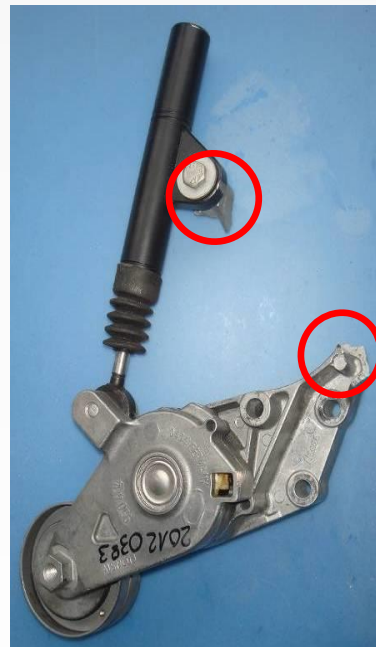

- GA357.09 related failures are a result of incorrect operation of the over-running alternator pulley, which is faulty and was not replaced at the same time as the roller tensioner.
- The resulting breakdown of the entire accessory drive leads to vehicle immobilization.



#### ADVICE

- It is best to replace the over-running freewheel alternator pulley at the same time as the belt to avoid premature failure (a breakdown in the over-running freewheel alternator pulley leads to other engine issues). To find the reference for your application, refer to the NTN-SNR "Accessories" catalog.
- Use suitable equipment to loosen and remove a pulley on the alternator and to ensure the correct performance of the system.
- Check the condition of your pulley as a pulley failure can cause breakage of the roller bearing.



## Tests to check the condition of the over-running freewheel alternator pulley.

- Engine idling: find any abnormal movement in the tensioner. If you see any, the over-running freewheel alternator pulley should be replaced.
- With the engine off, accessory belt filed: immobilize the alternator rotor (use a nonmetallic object). Rotate the pulley by hand, only one direction of rotation should be possible.

## ROLLER TENSIONER REPLACEMENT

### Recommendations for installing the roller tensioner

1) **Relieve the belt** by fixing the appropriately sized wrench on the nut at the rear of the roller tensioner GA357.09. Then remove the belt from the system. Remove the three screws then take off the roller tensioner.

2) **Reinstall the new roller tensioner** ensuring that all remaining screws are tightened to the torque specifications of the vehicle manufacturer. Always install a new belt (Ref. NTN-SNR CA6PK903)

## REMOVING THE BELT

- 1) Remove the engine undertray
- 2) Remove parts to access the roller
- 3) Move the roller tensioner with a spanner in a clockwise direction
- 4) Remove the accessory drive belt

## INSTALLING THE BELT

Proceed in the reverse order of removal

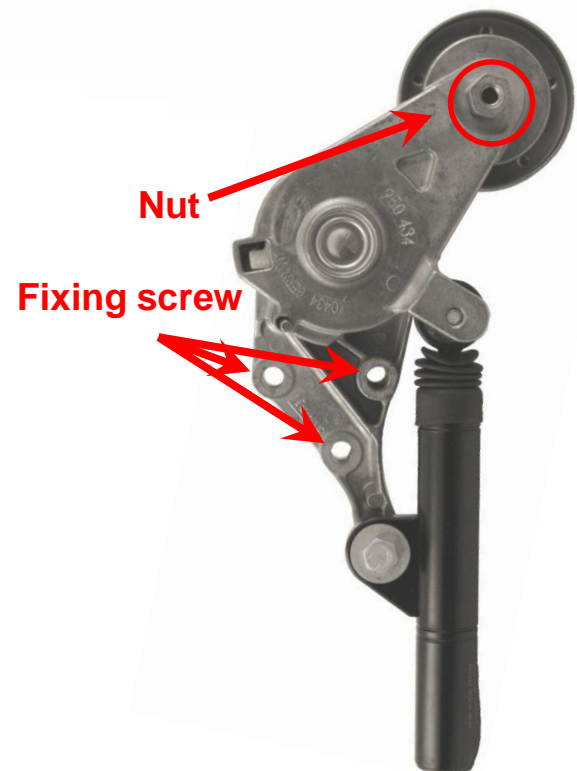

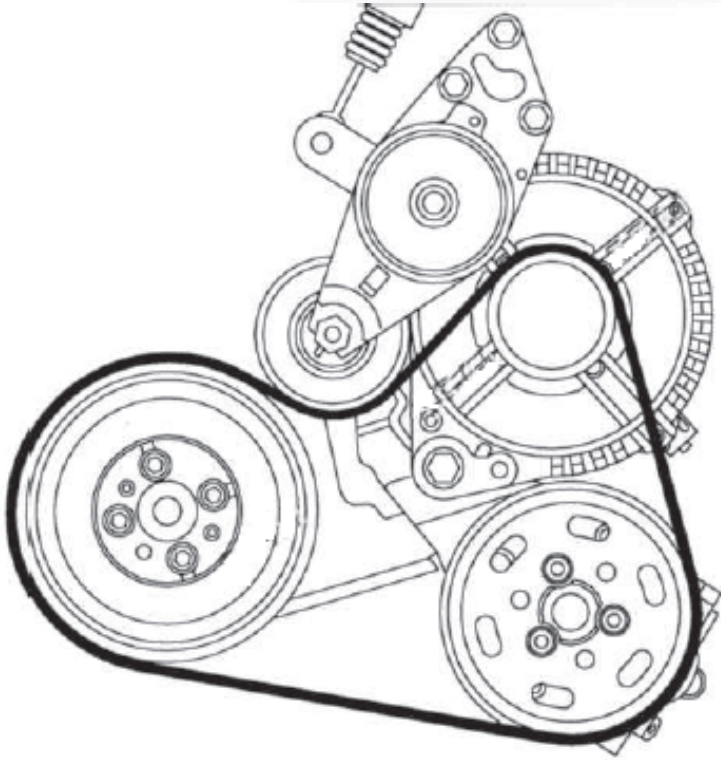

**Routing the accessory belt  
(vehicle without air conditioning)**

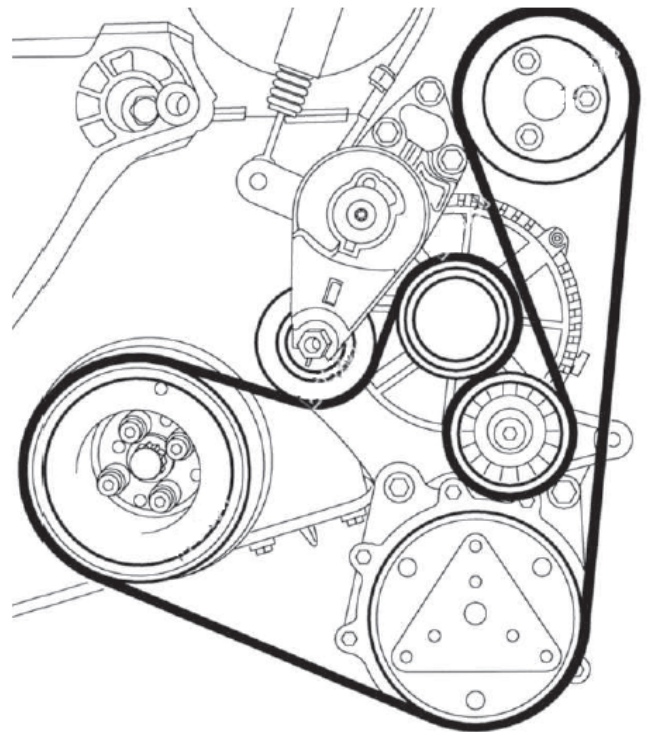

**Routing the accessory belt  
(vehicle with air conditioning)**

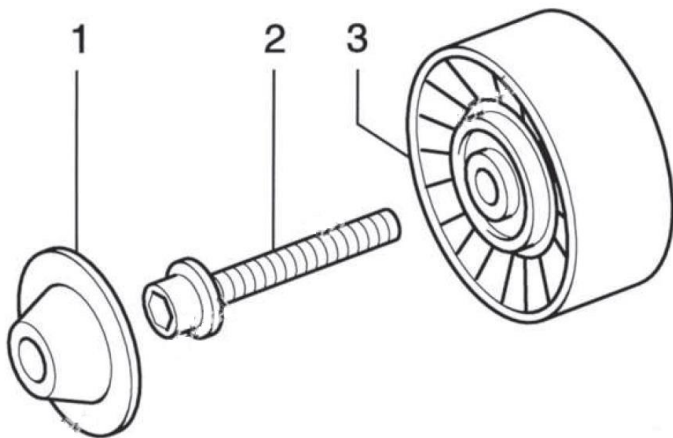

**Installing the belt guide roller  
(Ref. NTN-SNR GA357.06)  
(only for vehicles with air conditioning)**



## Replacing the accessory belt

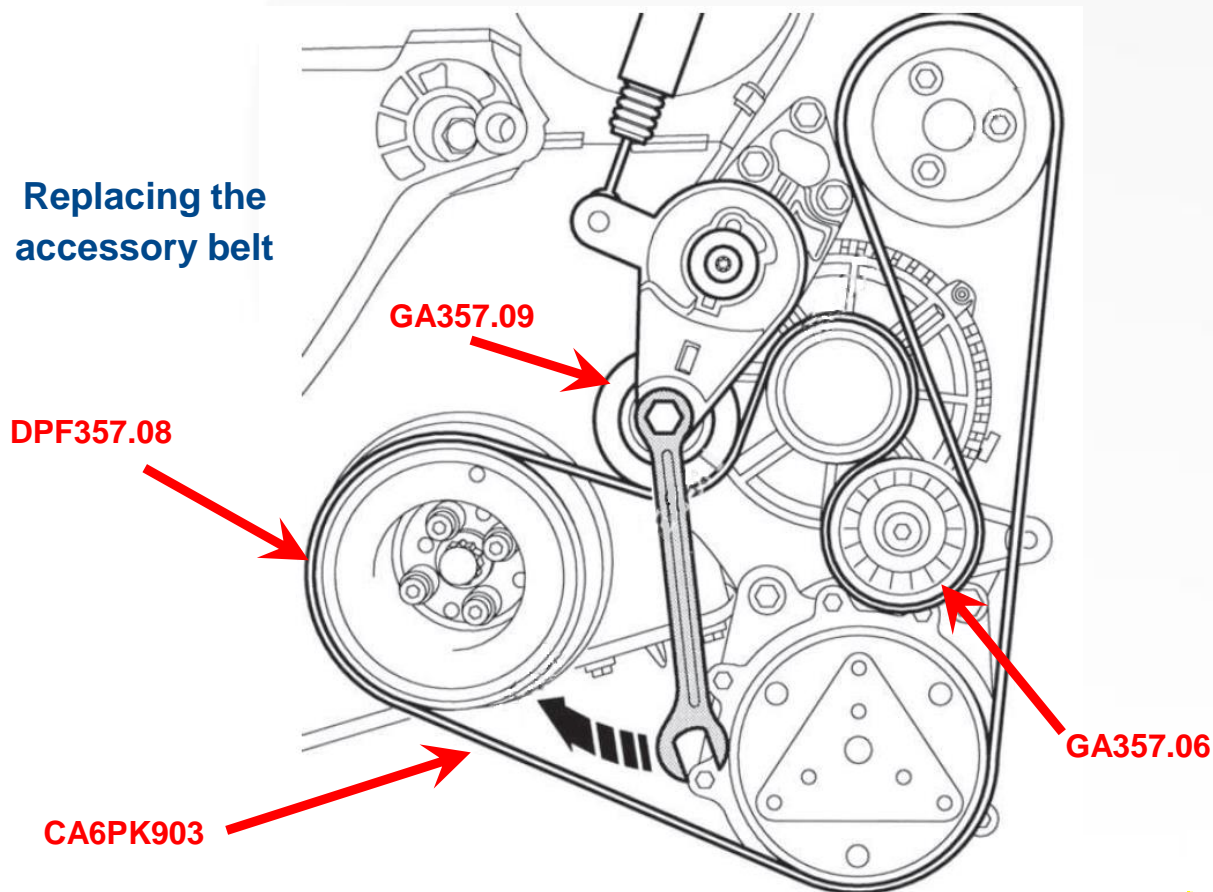

### Recommendations

The over-running freewheel alternator pulley is a wearing part whose operating condition is to be checked regularly.

It is highly recommended to replace the over-running freewheel alternator pulley every 120,000 km and systematically when replacing the belt tensioner.

Follow the manufacturers' assembly procedures as well as their indicated tightening torques. Consult vehicle applications in our online catalogue: [eshop](http://eshop)



Use this QR Code to find our online catalogue

**ALWAYS FOLLOW THE VEHICLE MANUFACTURER'S RECOMMENDATIONS!**

© NTN-SNR ROULEMENTS

The contents of this document are the copyright of the publisher and any reproduction, even partial, is prohibited without permission. Despite the care taken in preparing this document, NTN-SNR Roulements disclaims any liability for errors or omissions that may slip through, and for losses or direct or indirect damages arising from its use.

