



HYDRAULIC TENSIONERS

RECOMMENDATIONS FOR RE-SETTING OF A HYDRAULIC TENSIONER

THE DIFFERENT TYPES OF HYDRAULIC TENSIONERS



DESCRIPTION

NTN hydraulic tensioners are basically a metal cylinder which contains a piston rod, seals, springs and oil which can withstand large temperature variations.

The tensioner only delivers adjustment pressure to the belt or chain when the retaining pin is removed.

Although hydraulic tensioners look very different they all function in a very similar way.

THE ADVANTAGES OF USING AN HYDRAULIC TENSIONER

Perfect adjustment of belt/chain tension at all times - Absorption of tension variation - Resistance to temperature variations – Longer lifespan – Less noise

The main advantage of using a hydraulic tensioner is its ability to rapidly compensate for changes in belt or chain tension due to engine temperature. As the engine warms up the belt or chain will lengthen. The hydraulic tensioner will automatically compensate for this, ensuring optimum tension is maintained to prevent the chain or belt from slipping and so avoiding engine damage.

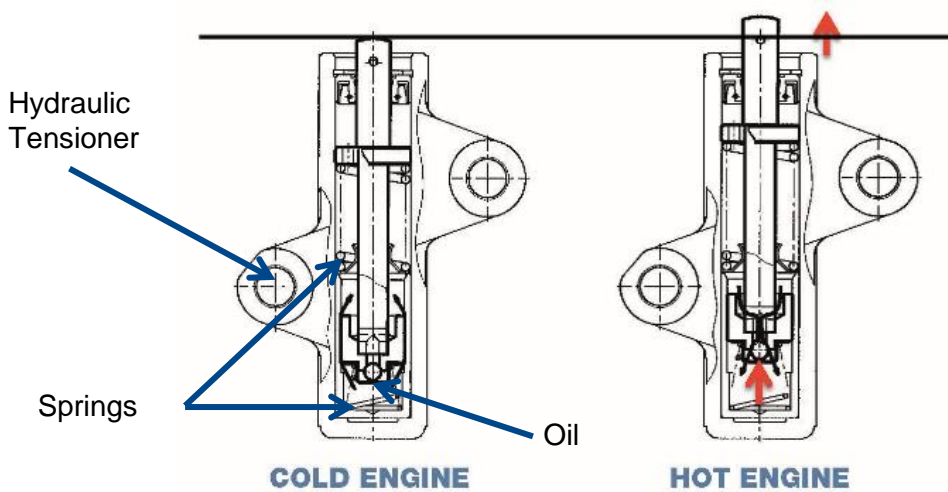

Pressure applied by the hydraulic damper when the engine works at high temperature

COMMON PROBLEMS

The mechanic removes the retaining pin from the tensioner before the timing system is fully assembled or finds that the belt needs to be removed due to timing mark misalignment.

If the pin is removed before the belt or chain is fitted pressure is applied to the tensioner arm, this then makes it impossible to correctly fit the belt or chain.



RECOMMENDATION FOR RE-SETTING THE HYDRAULIC TENSIONER

If the pin has been removed at the incorrect time, the hydraulic tensioner needs to be re-set correctly for it to function correctly when re-installed.

- Stand the hydraulic tensioner vertically (this lets the oil return to the bottom of the tensioner body)
- Place the hydraulic tensioner vertically on the press bed, bring the press's piston down until it makes contact with the tensioner piston rod. Gently press tensioner piston rod back into the tensioner body using a maximum force of 980kg. (it is recommended that the tensioner rod is pressed in with 2-3 sort rests)
- The retaining pin can now be replaced, and the press can then be released. TIP: if the original pin can not be used a allen key is ideal





Never re-set a Hydraulic tensioner in a vice, when the tensioner is re-set on its side the oil is distributed around the body of the tensioner. As all the oil is no longer in the oil reservoir of the tensioner it can no longer function correctly. The lack of oil in the reservoir means the tensioner can not generate the correct tensioning force. Lack of tensioning force leads to loose belts and chains, this causes noise, premature wear and the possibility of belt or chain failure.



Recommendations



Hydraulic tensioners are a wearable part that withstand a lot of stress when in operation. NTN Europe recommend that hydraulic tensioners are checked for leaks and wear on a regular basis. A leaking or worn tensioner can cause the chain or belt to wear prematurely leading to failures and engine damage.

Hydraulic tensioners should always be replaced at the same time as the timing belt or timing chain system is replaced.

The vehicle manufacturer's installation procedures and specified tightening torques should always be applied.

Refer to the vehicle applications in our online catalogue: [e-shop](#)



Scan this QR code to access our online catalogue.

FOLLOW THE RECOMMENDATIONS OF THE VEHICLE MANUFACTURER!

© NTN-SNR ROULEMENTS

The contents of this document are the copyright of the publisher and any reproduction, even partial, is prohibited without permission. Despite the care taken in preparing this document, NTN-SNR Roulements disclaims any liability for errors or omissions that may slip through, as well as for losses or direct or indirect damage arising from its use.

